

PRICE LIST 2022



i prezzi sono in euro IVA esclusa
prices are in euros VAT not included
les prix sont en euro hors TVA
die preise sind in euro ohne MwSt.
los precios son en euros sin IVA

PRICE LIST 2022





via Del Lavoro 2
35010 Trebaseleghe PD - Italy
tel. +39 049 938 7633
info@extendoweb.com
www.extendoweb.com



LIVING SYSTEMS

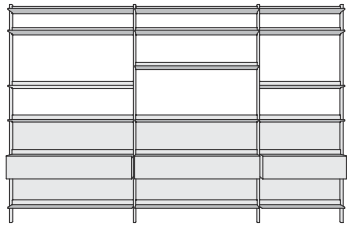

EWS
pg. 26

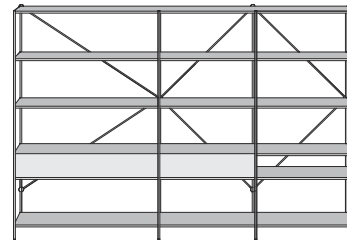

XY
pg. 66

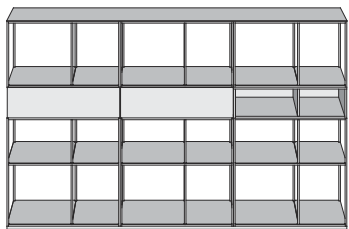

ATELIER
pg. 36

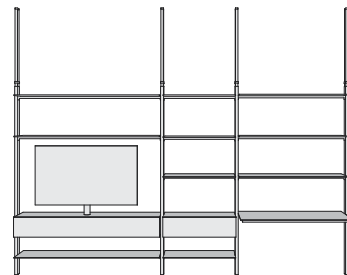

SYSTEM
pg. 80

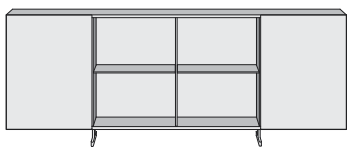

MONOLITH
pg. 52

TABLES

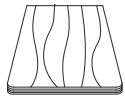
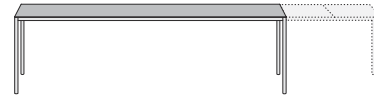
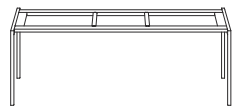

TABLE
MATERIALS
pg. 90



ST35
fixed | extendable
pg. 132



FRAMES
pg. 98

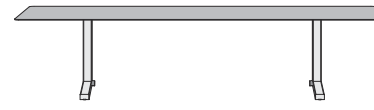

IPE
fixed
pg. 144

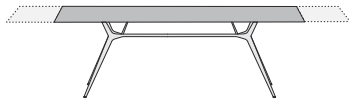

BALANCE
fixed | extendable
pg. 102

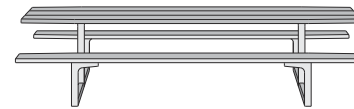

HAMMER
fixed
pg. 150

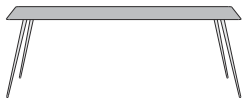

SPILLO
fixed
pg. 114

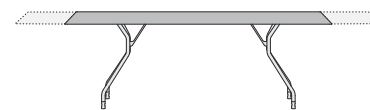

T7
fixed | extendable
pg. 152

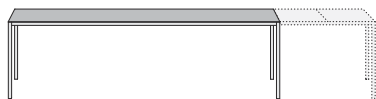

SINTESI
fixed | extendable
pg. 120

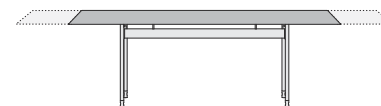

T8
fixed | extendable
pg. 158

COFFEE TABLES

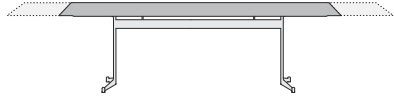

T9
fixed | extendable
pg. 168



T10
fixed
pg. 176

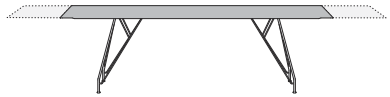

T11
fixed | extendable
pg. 182

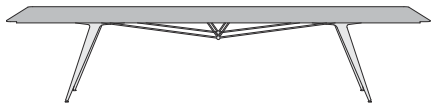

T12
fixed
pg. 190

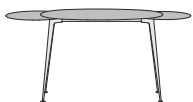

MR.HYDE
fixed | extendable
pg. 196



SPILLO
fixed
pg. 118

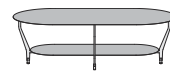

DECÓ
fixed
pg. 198



MR.HYDE
fixed | extendable
pg. 196

SEATINGS



DANSKE C
pg. 204



VIKING
pg. 206

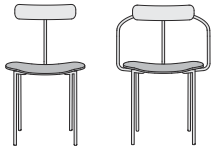

ECH3
pg. 208



ECH4
pg. 210



ECH5
pg. 212



ECH6
pg. 214

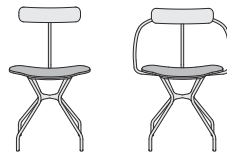

ECH7
pg. 218

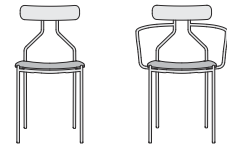

ECH8
pg. 220



ECH9
pg. 222

LAMPS

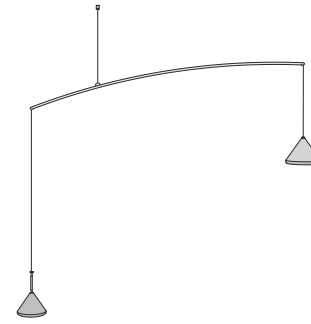

CONTRAPPESO
suspension
pg. 224

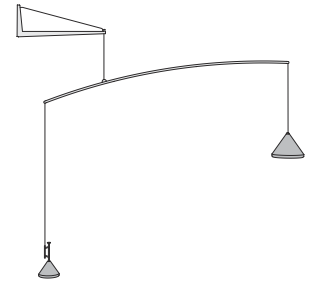

wall
pg. 226

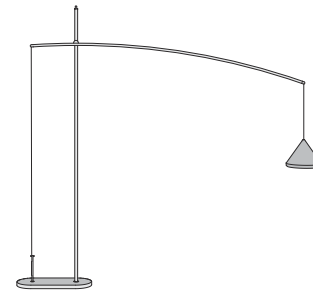

floor
pg. 227

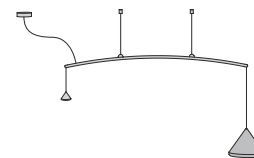

ceiling
pg. 228

MULTIMEDIA

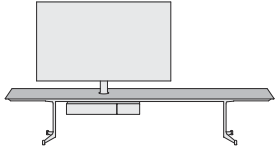

CONNECT
tv dimensions: 40" - 85"
pg. 234

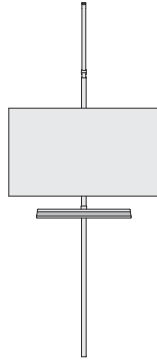

SYSTEM
MULTIMEDIA
tv dimensions: 40" - 65"
pg. 242

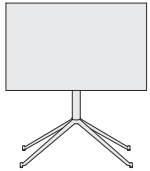

APOLLO
tv dimensions: 40" - 65"
pg. 238

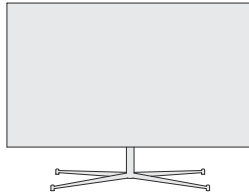

TITANO
tv dimensions: 55" - 85"
pg. 246

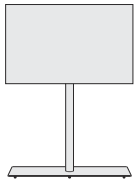

SPIN 360
tv dimensions: 40" - 65"
pg. 240

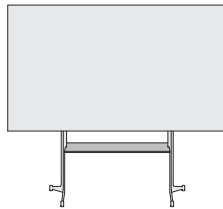

URANO
tv dimensions: 55" - 85"
pg. 248

WALK-IN CLOSETS

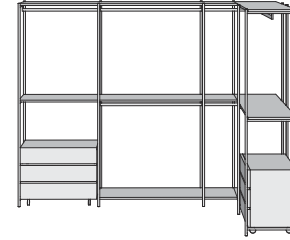

SLIDE
pg. 250

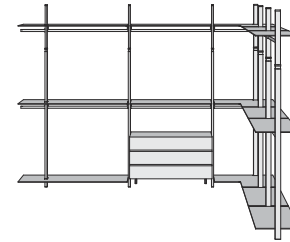

PERSONAL
pg. 256

05/EWS pg.30
5886 €

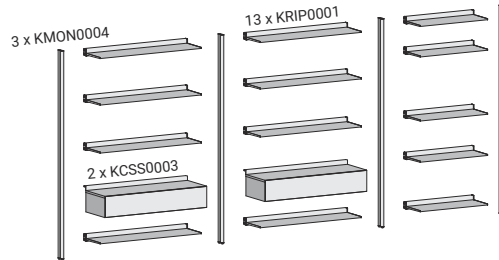
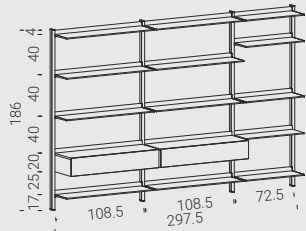

04/EWS pg.32
5147 €

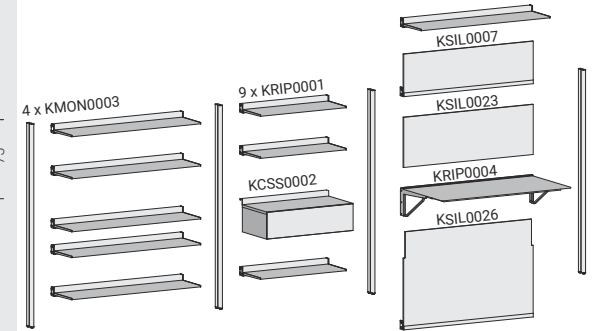
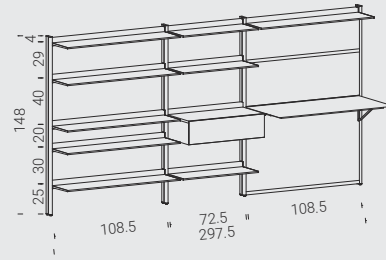

02/EWS pg.34
5404 €

▲ barre led incluse
led light bars included

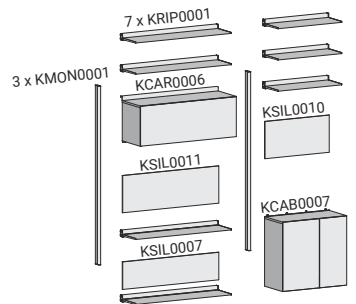
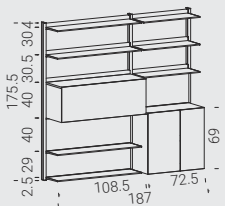

03/EWS pg.36
6352 €

▲ barre led incluse
led light bars included

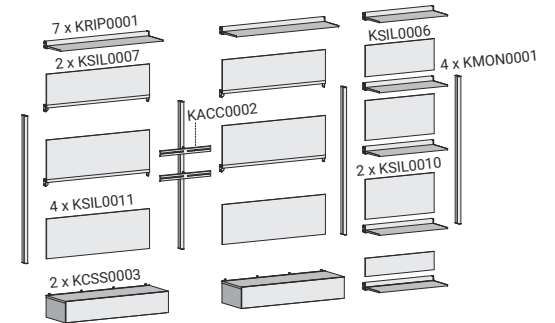
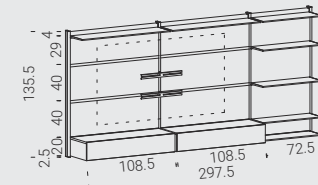

06/EWS pg.40
8226 €

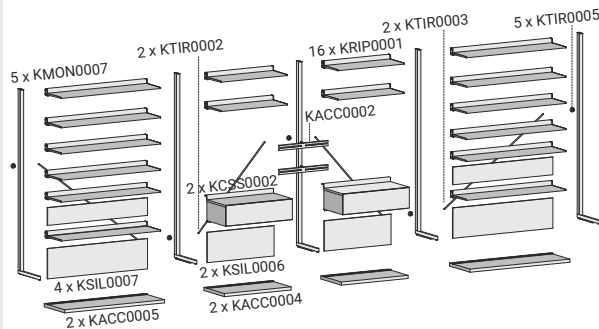
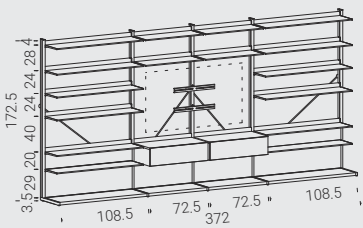

01/EWS pg.44
1551 €

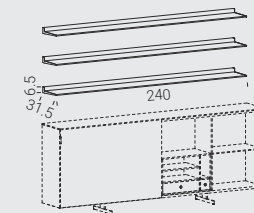

09/ATELIER pg.50
4317 €

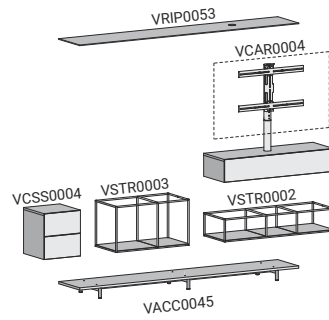
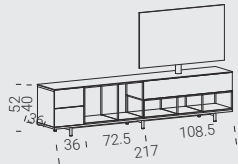

02/ATELIER pg.52
7399 €

▲ accessori interni non inclusi
internal accessories not included

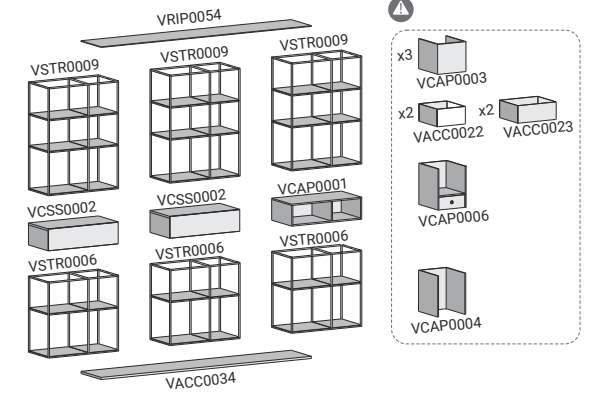
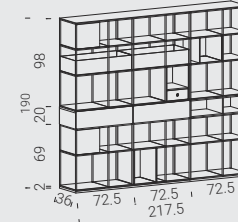

04/ATELIER pg.54
2786 €

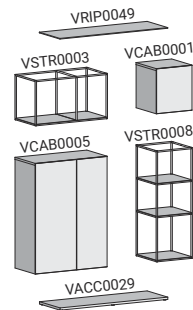
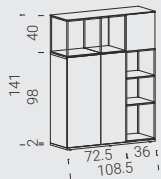

01/ATELIER pg.56
3941 €

▲ top in marmo non incluso
marble top not included

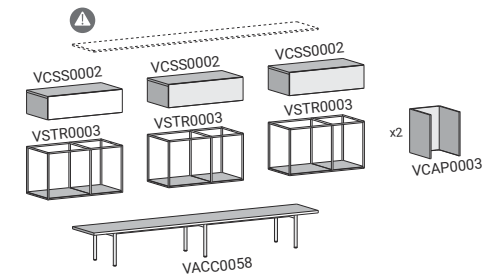
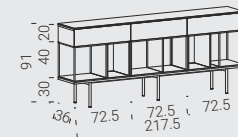

12/ATELIER pg.58
3807 € 2460 €

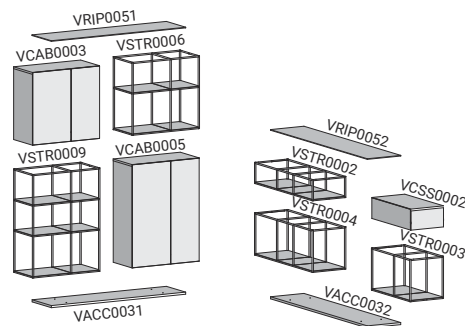
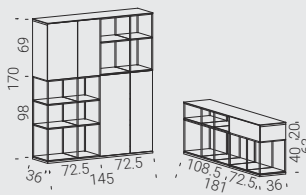

03/ATELIER pg.60
2377 €

▲ top in marmo non incluso
marble top not included

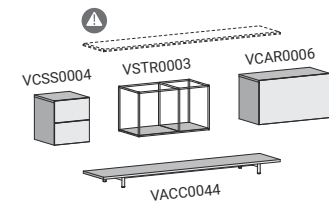
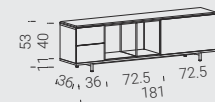

11/ATELIER pg.62

8594 €

▲ barre led incluse
led light bars included

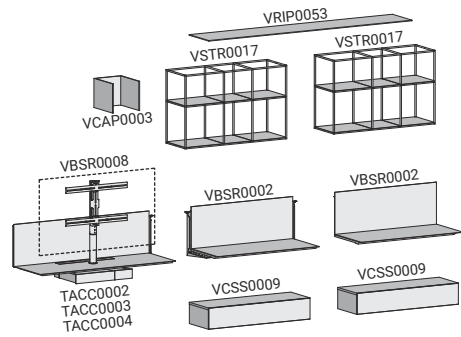
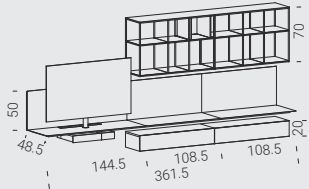

10/ATELIER pg.64

3888 €

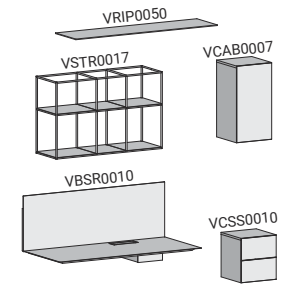
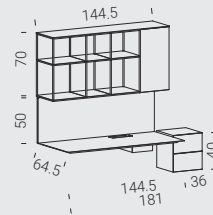

13/ATELIER pg.66

3943 €

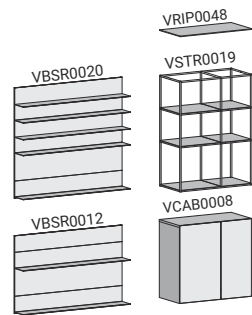
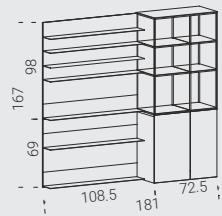

05/ATELIER pg.68

2034 €

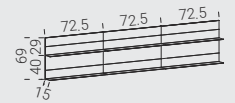

3817 €

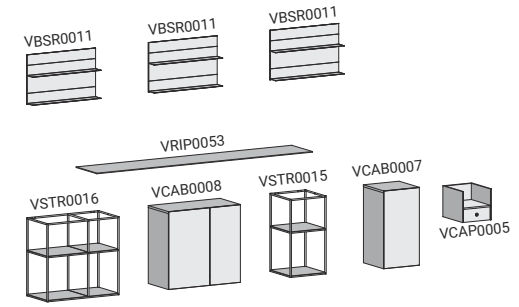
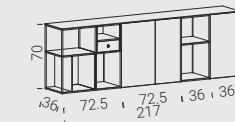

06/ATELIER pg.70

5705 €

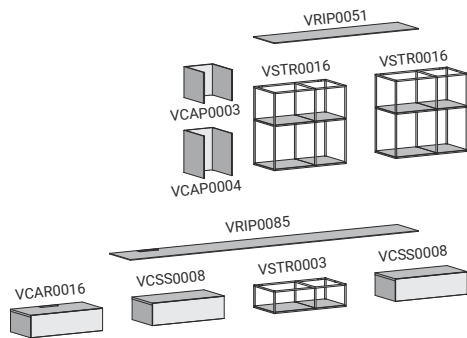
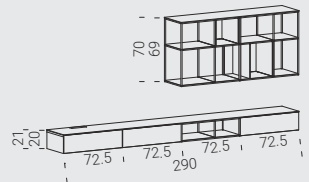

07/ATELIER pg.72

1617 €

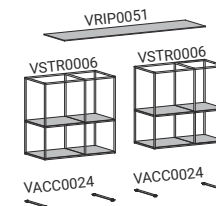
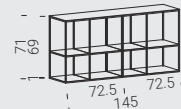



08/ATELIER pg.73

1983 €

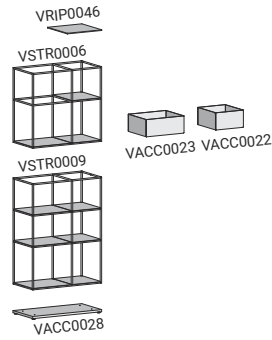
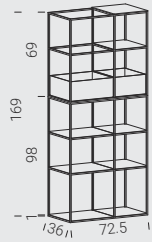

MONOLITH

11/MONOLITH pg.78

5293 €

⚠ ripiani EWS non inclusi
EWS shelves not included

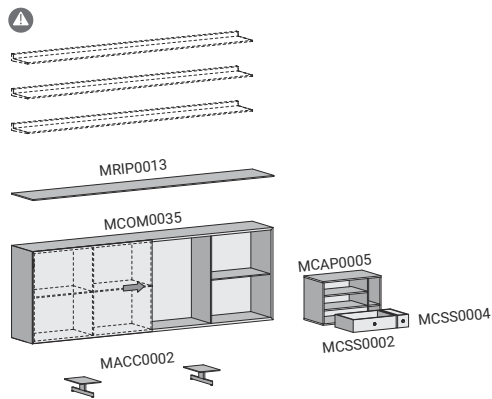
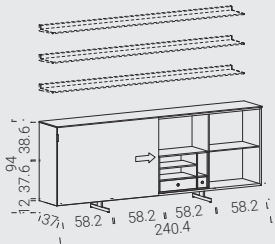

09/MONOLITH pg.80

3912 €

⚠ top in marmo non incluso
marble top not included

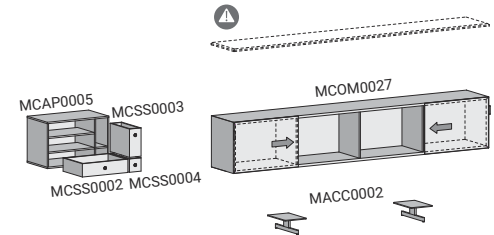
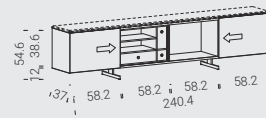

04/MONOLITH pg.84

3067 €

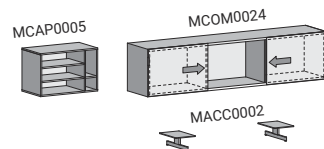
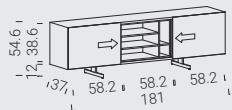

10/MONOLITH pg.86

5403 €

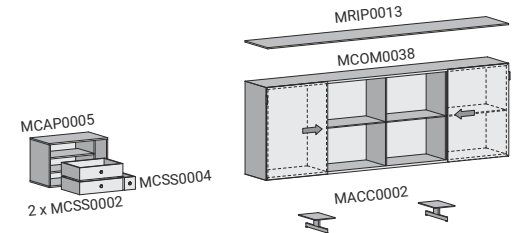
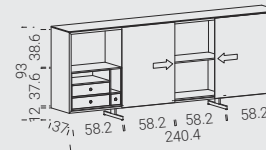

06/MONOLITH pg.88

4673 €

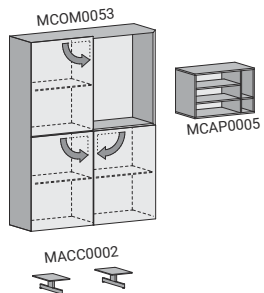
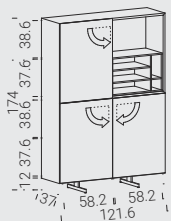

02/MONOLITH pg.89

4059 €

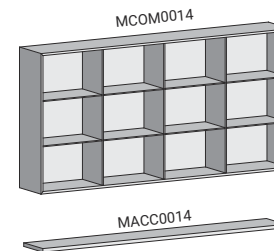
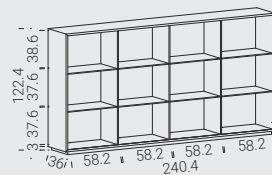

02A/MONOLITH pg.90

4843 €

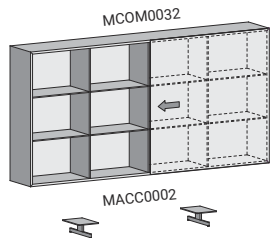
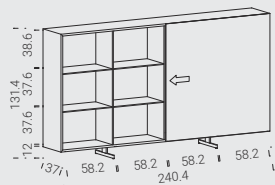

05/MONOLITH pg.92

4300 €

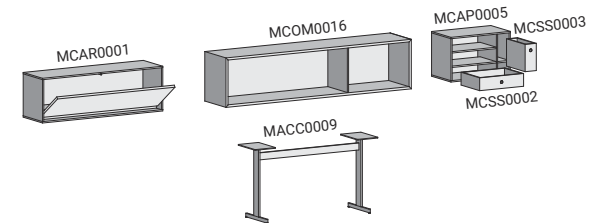
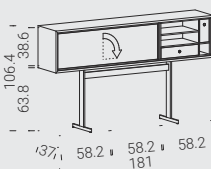

32/XY pg.98

5811 €

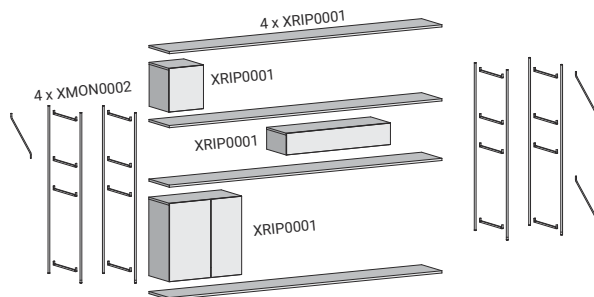
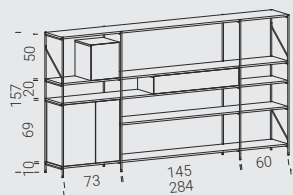

31/XY pg.102

3404 €

⚠ top in marmo non incluso
marble top not included

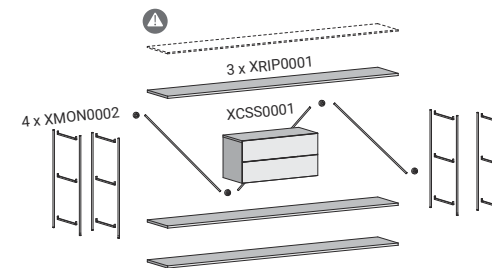
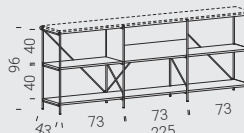

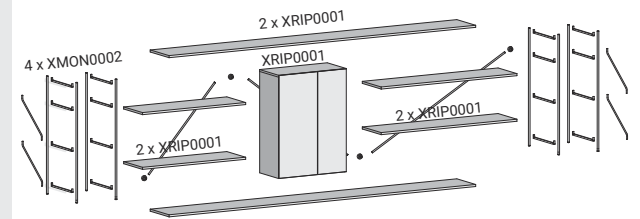
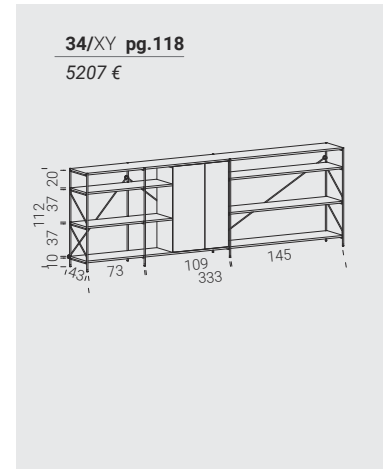
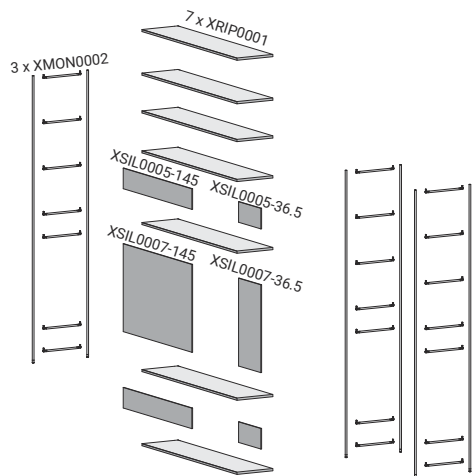
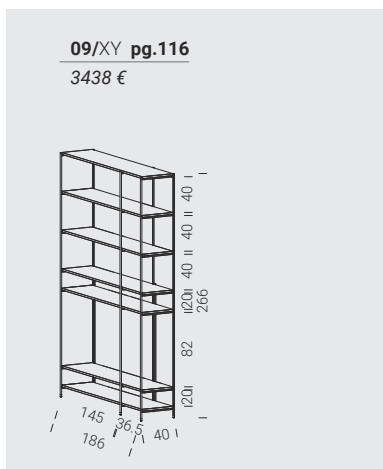
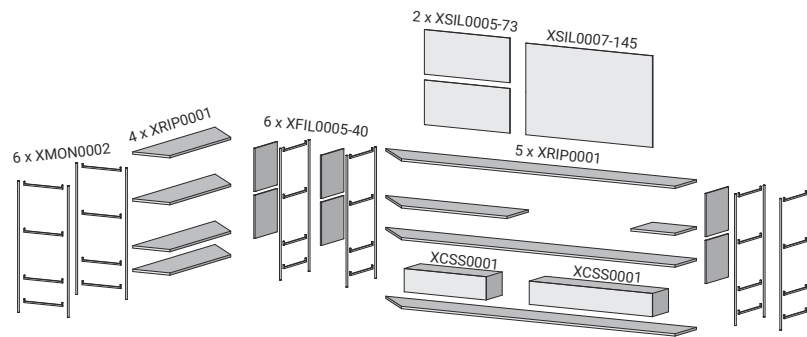
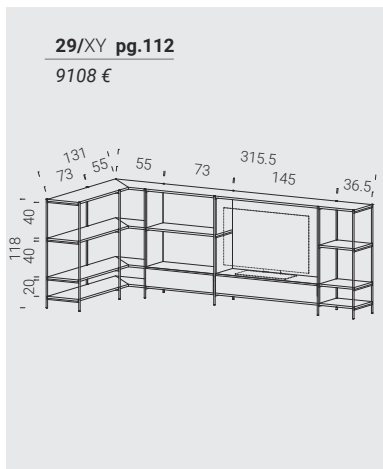
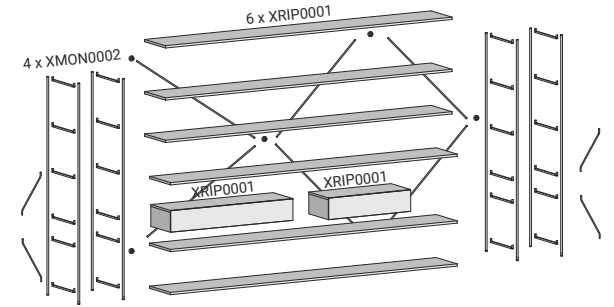
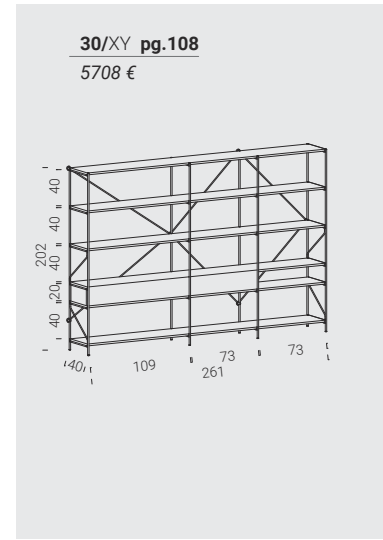
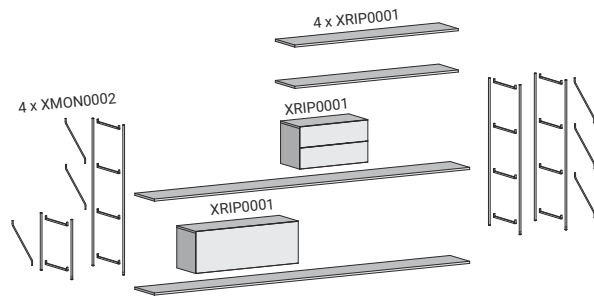
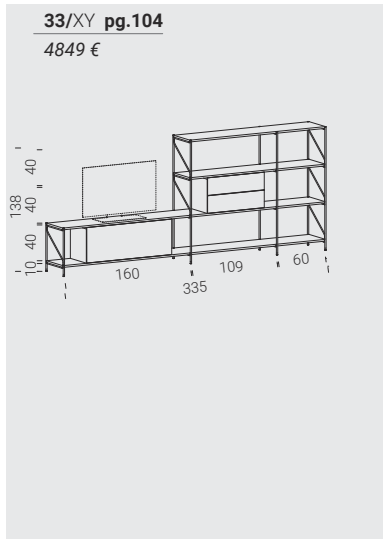

56/SYSTEM pg.124

6934 €

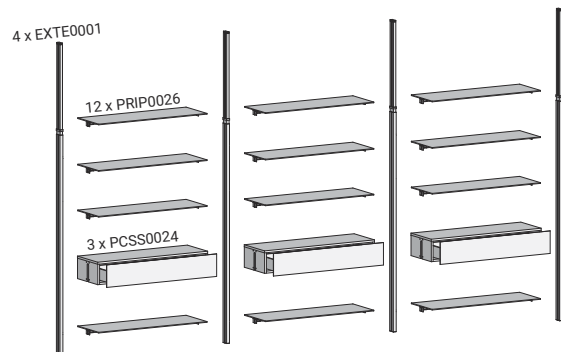
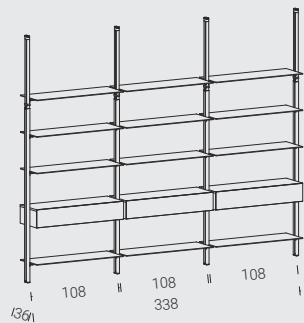

54/SYSTEM pg.126

7481 €

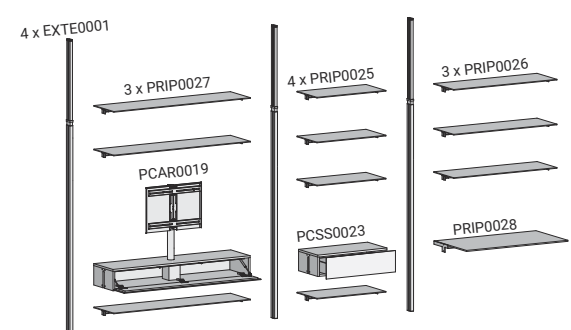
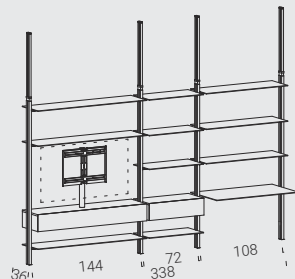

16/SYSTEM pg.130

3432 €

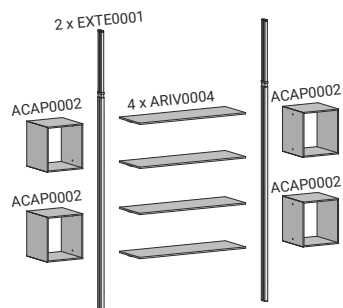
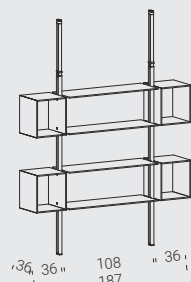

14/SYSTEM pg.131

4172 €

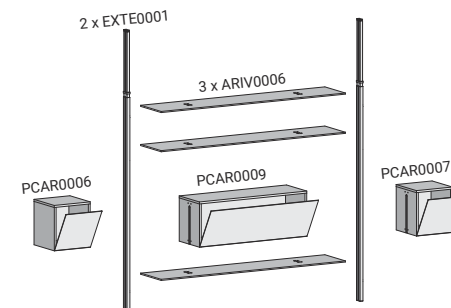
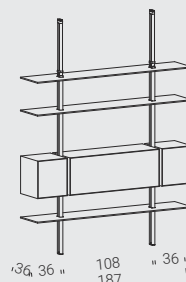

03/SYSTEM pg.132

3990 €

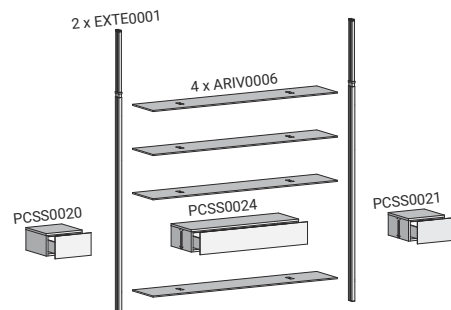
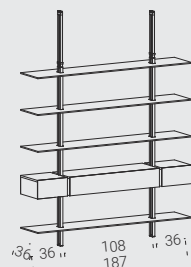

52/SYSTEM pg.134

3907 €

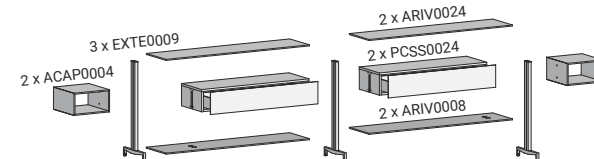
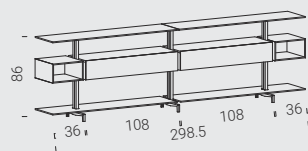



53/SYSTEM pg.136
7750 €

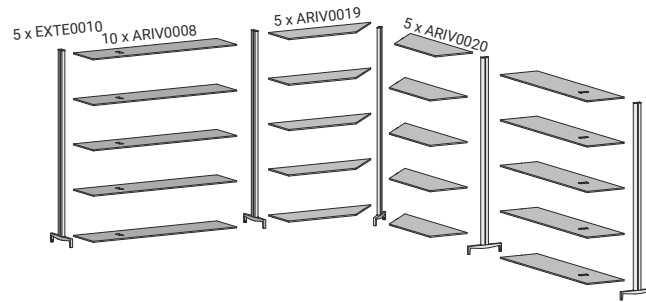
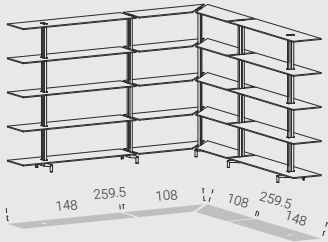

 **BALANCE**

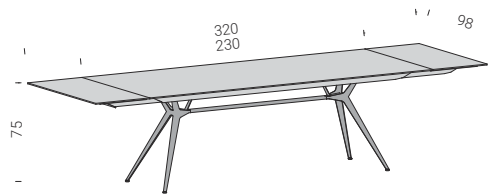

10/BALANCE pg.144
4771 €

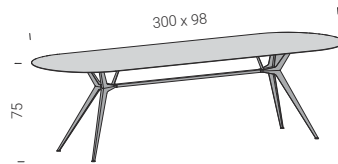

08/BALANCE pg.146
3145 €

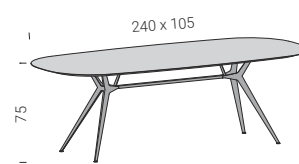

09/BALANCE pg.148
3265 €

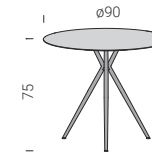

04/BALANCE pg.150
1417 €

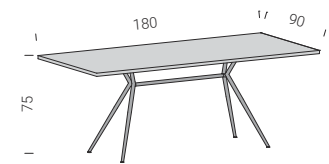

06/BALANCE pg.152
2568 €

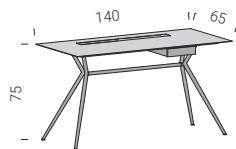

05/BALANCE pg.154
2176 €

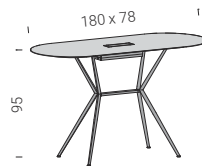

07/BALANCE pg.156
2252 €

SPILLO

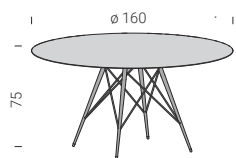

28/SPILLO pg.160
2713 €

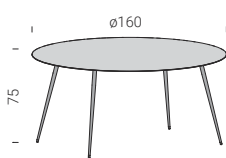

24/SPILLO pg.162
2344 €

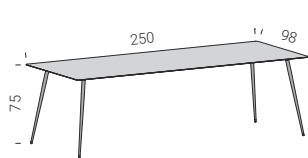

04/SPILLO pg.164
3026 €

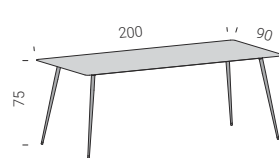

05/SPILLO pg.166
2562 €

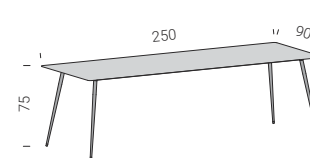

21/SPILLO pg.167
2561 €

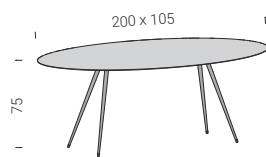

25/SPILLO pg.168
2729 €

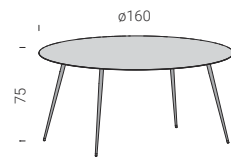

22/SPILLO pg.170
2676 €

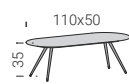

26/SPILLO pg.172
1234 €

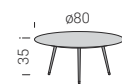

978 €

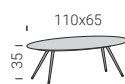

1286 €



688 €



27/SPILLO pg.173
688 €

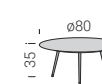

978 €



452 €

SINTESI

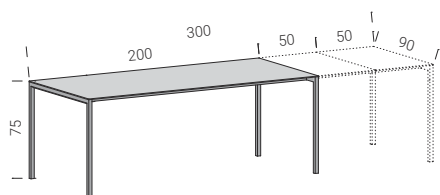

01/SINTESI pg.176
3631 €

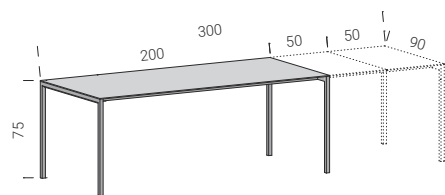

02/SINTESI pg.178
4077 €

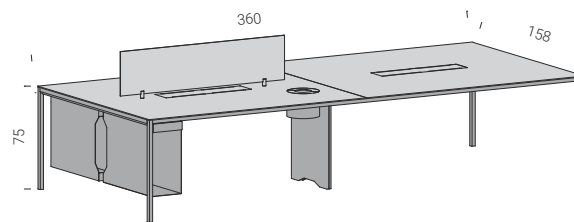

03/SINTESI pg.180
8011 €

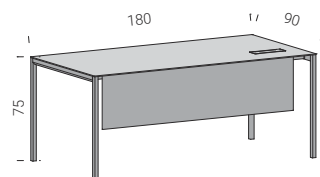

04/SINTESI pg.184
2659 €

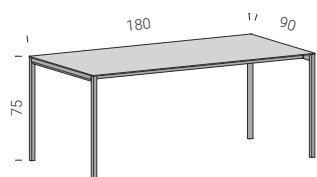

05/SINTESI pg.185
2007 €

 ST35

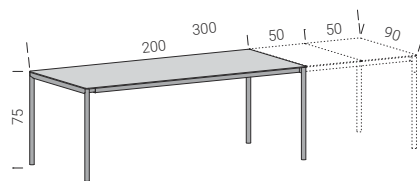

05/ST35 pg.188
4077 €

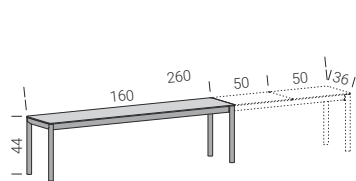

05/ST35 pg.188
2508 €

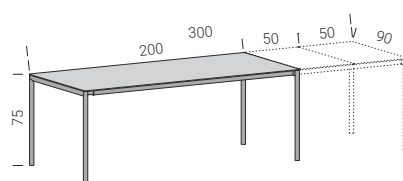

02/ST35 pg.190
4077 €

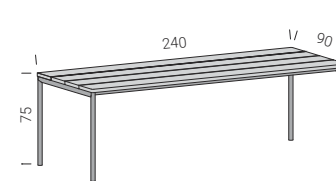

01/ST35 pg.194
4119 €

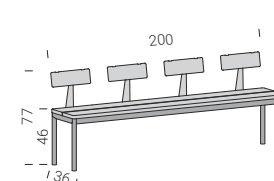

01/ST35 pg.194
3720 €

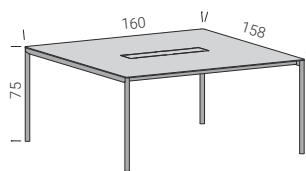

03/ST35 pg.198
3482 €

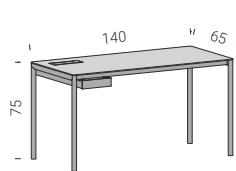

04/ST35 pg.200
2146 €

 IPE

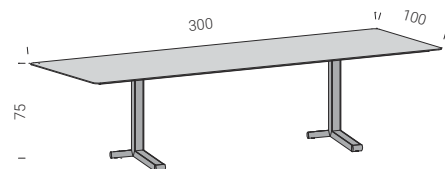

01/IPE pg.204
4514 €

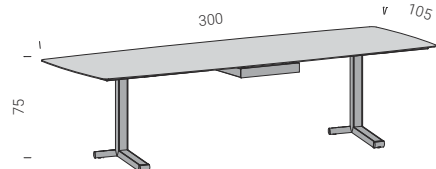

03/IPE pg.206
5250 €

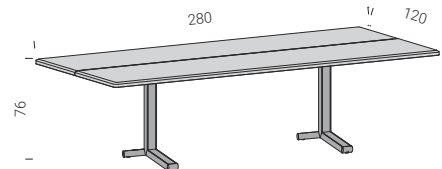

02/IPE pg.208
5867 €

 HAMMER

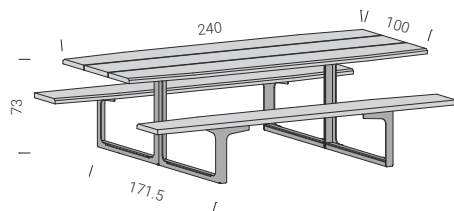

04/HAMMER pg.212
6925 €

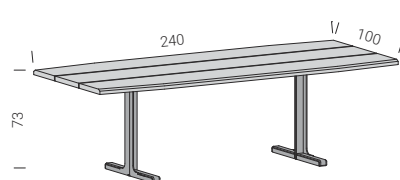

05/HAMMER pg.214
4337 €

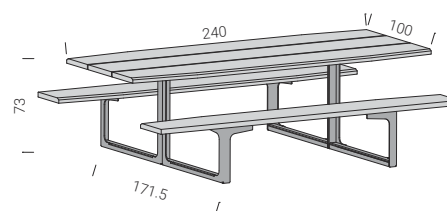

06/HAMMER pg.216
7532 €

 T7

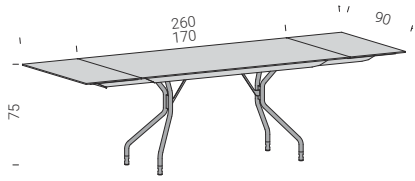

03/T7 pg.220
4009 €

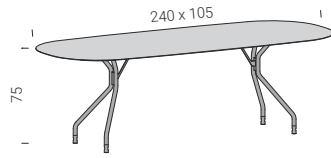

01/T7 pg.222
3042 €

 T8

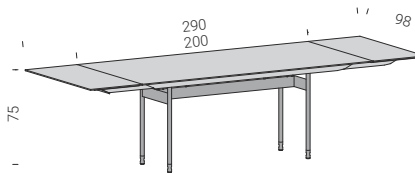

05/T8 pg.226
3969 €

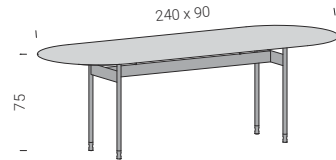

01/T8 pg.228
2454 €

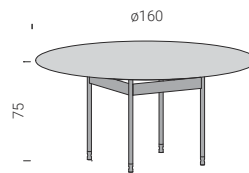

04/T8 pg.230
2382 €

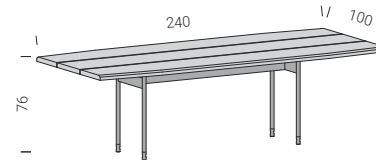

02/T8 pg.232
4365 €

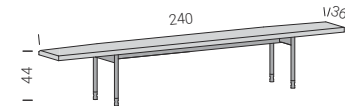

02/T8 pg.232
2309 €

 T9

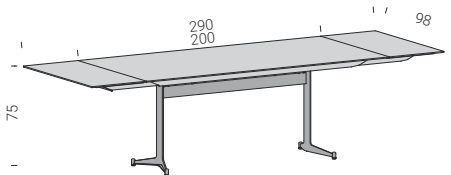

04/T9 pg.236
4011 €

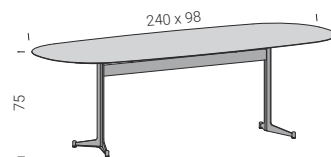

02/T9 pg.238
2915 €

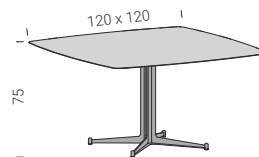

03/T9 pg.240
2188 €

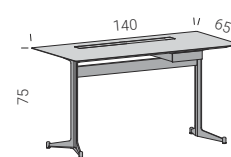

01/T9 pg.242
2662 €

 T10

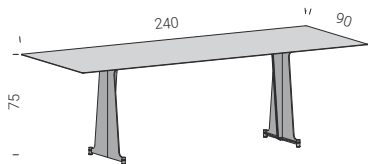

02/T10 pg.246
3487 €

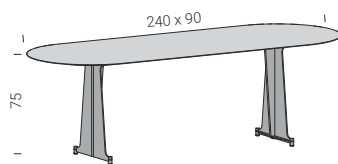

01/T10 pg.248
3459 €

 T11

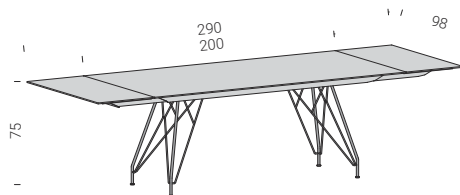

03/T11 pg.252
4587 €

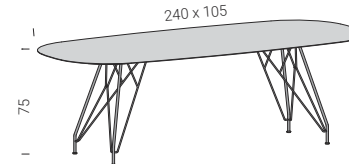

02/T11 pg.254
4823 €

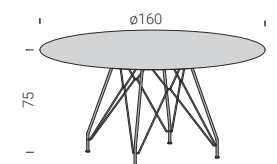

01/T11 pg.256
2799 €

T12

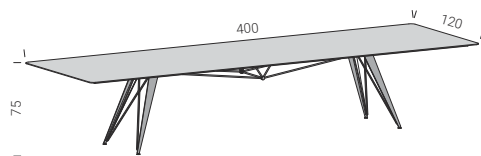

01/T12 pg.260
5561 €

MR.HYDE



28/MR.HYDE pg.266
1543 €



29/MR.HYDE pg.268
2129 €

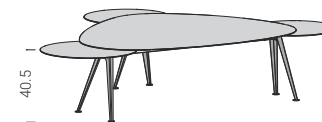

02/MR.HYDE pg.270
1877 €

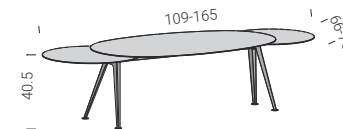

09/MR.HYDE pg.271
1384 €

DÉCO

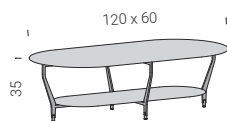

03/DÉCO pg.274
1442 €

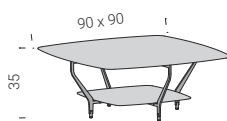

05/DÉCO pg.275
1467 €

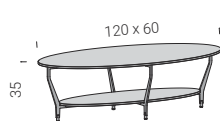

06/DÉCO pg.276
2980 €

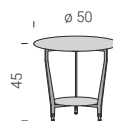

04/DÉCO pg.277
1962 €

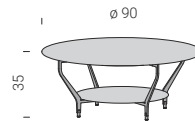

01/DÉCO pg.278
1467 €

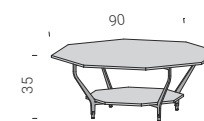

02/DÉCO pg.279
2980 €

DANSKE C



01/DANSKE C pg.284
491 €



02/DANSKE C pg.286
639 €



05/DANSKE C pg.288
538 €



03/DANSKE C pg.290
452 €



04/DANSKE C pg.292
528 €

VIKING



01/VIKING pg.296
781 €



06/VIKING pg.298
781 €



07/VIKING pg.300
414 €



05/VIKING pg.301
643 €

ECH3



01/ECH3 pg.304
586 €

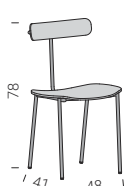

02/ECH3 pg.305
408 €

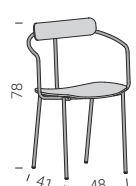

04/ECH3 pg.306
364 €



03/ECH3 pg.307
547 €

ECH4



02/ECH4 pg.310
406 €



466 €



01/ECH4 pg.312
454 €



03/ECH4 pg.313
451 €

ECH5

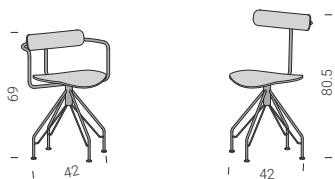

01/ECH5 pg.316

554 €



545 €

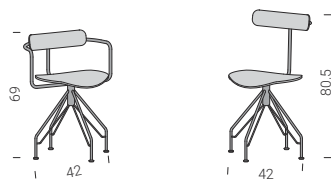

02/ECH5 pg.317

552 €



542 €

ECH7



04/ECH7 pg.326

462 €



02/ECH7 pg.327

602 €



01/ECH7 pg.328

614 €



03/ECH7 pg.329

597 €

ECH9

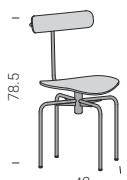

01/ECH9 pg.336

445 €



454 €

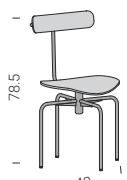

02/ECH9 pg.337

511 €



528 €

ECH6



01/ECH6 pg.320

497 €



02/ECH6 pg.321

458 €



03/ECH6 pg.322

462 €



04/ECH6 pg.323

342 €



366 €

ECH8



01/ECH8 pg.332

345 €



02/ECH8 pg.333

427 €

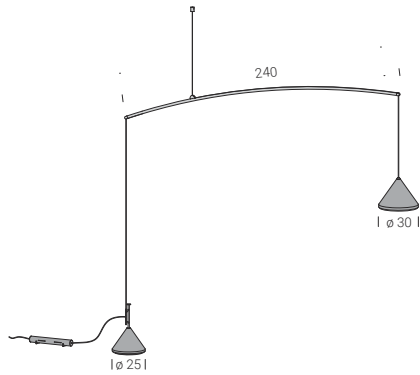

04/CONTRAPPESO pg.342 (SUSPENSION)
1717 €

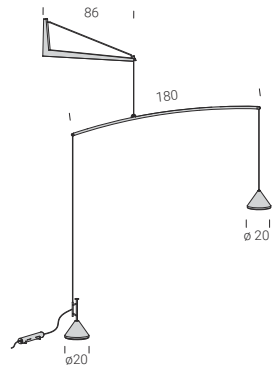

01/CONTRAPPESO pg.344 (WALL)
1090 €

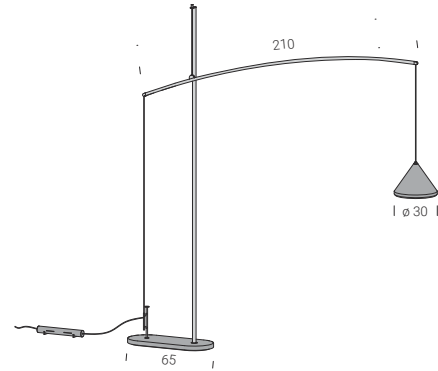

02/CONTRAPPESO pg.345 (FLOOR)
1452 €

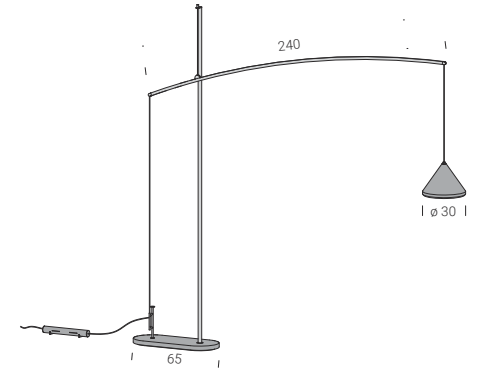

03/CONTRAPPESO pg.346 (FLOOR)
1452 €

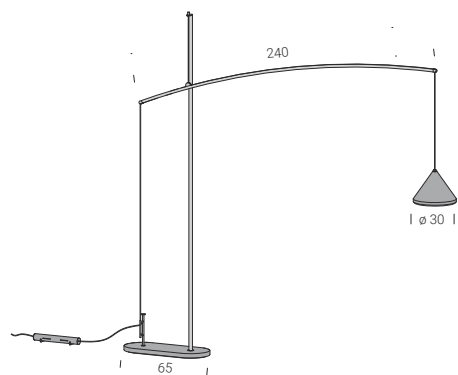

05/CONTRAPPESO pg.347 (FLOOR)
1452 €

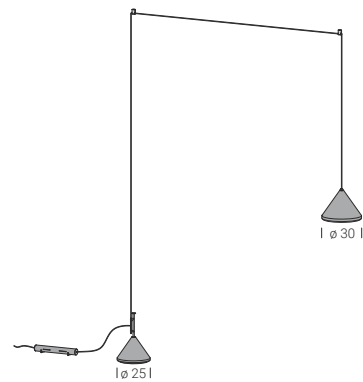

09/CONTRAPPESO pg.348 (SUSPENSION)
1610 €

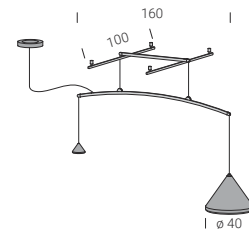

08/CONTRAPPESO pg.350 (CEILING)
1100 €

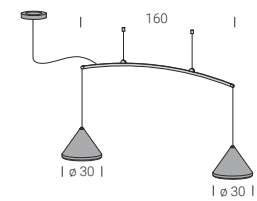

06/CONTRAPPESO pg.352 (CEILING)
1052 €

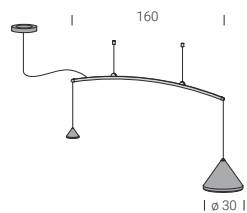

07/CONTRAPPESO pg.353 (CEILING)
839 €

CONNECT

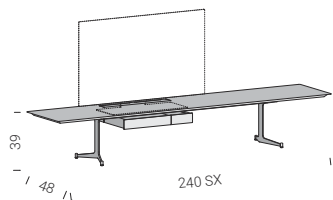
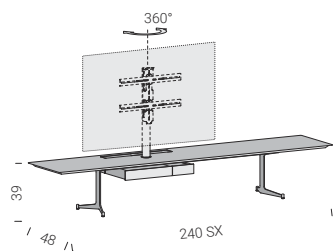

01/CONNECT pg.358
2947 €

02/CONNECT pg.362
2371 €

APOLLO

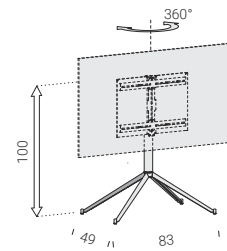

02/APOLLO pg.366
780 €

SPIN360

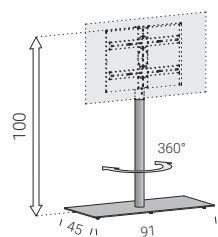

01/SPIN360 pg.372
860 €

SYSTEM MULTIMEDIA

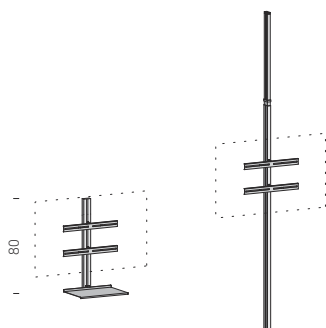

55/SYSTEM MULTIMEDIA pg.378
417 € 566 €

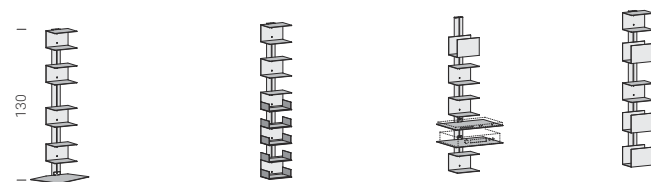

23/SYSTEM MULTIMEDIA pg.380
455 € 490 € 558 € 400 €

TITANO

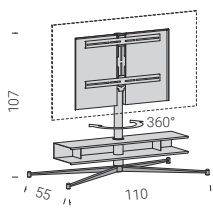

01/TITANO pg.384
1150 €

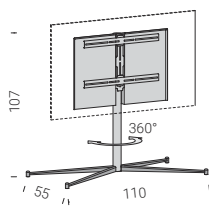

02/TITANO pg.386
880 €

URANO

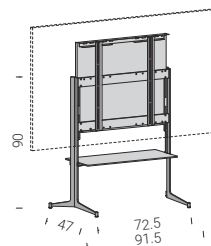

01/URANO pg.390
1080 €

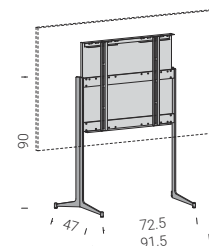

02/URANO pg.392
840 €

01/SLIDE pg.400
5181 €

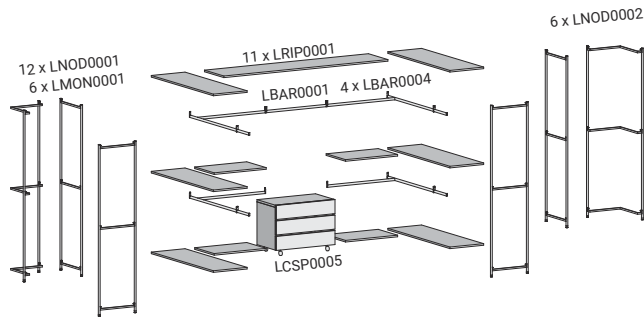
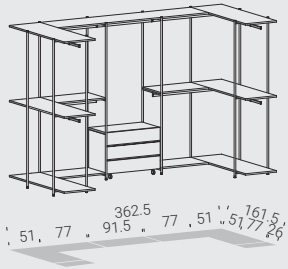

04/SLIDE pg.404
7583 €

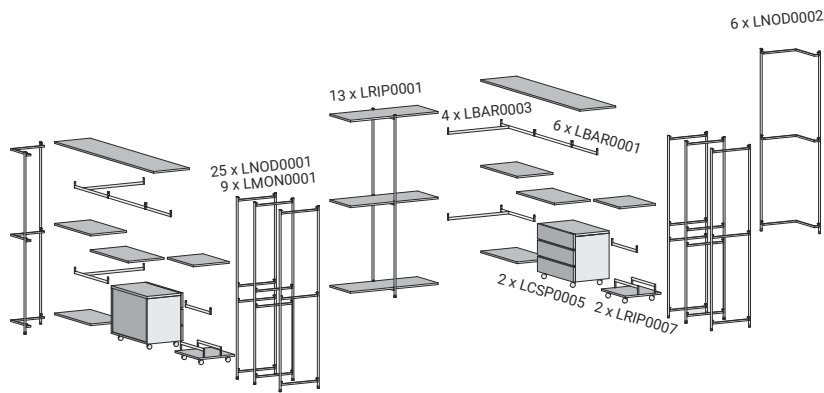
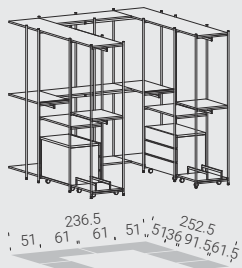

03/SLIDE pg.408
5217 €

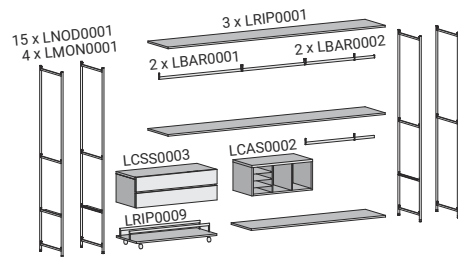
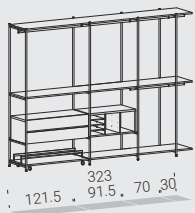

02/SLIDE pg.410
5506 €

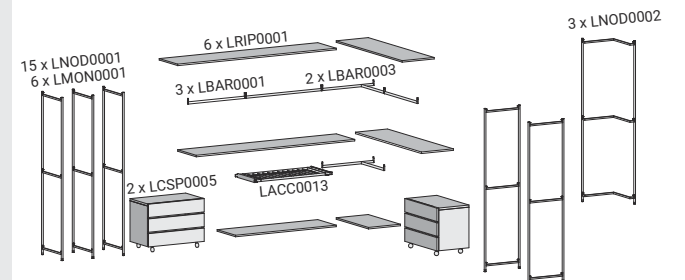
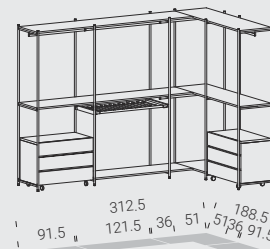

01/PERSONAL pg.416

10203 €

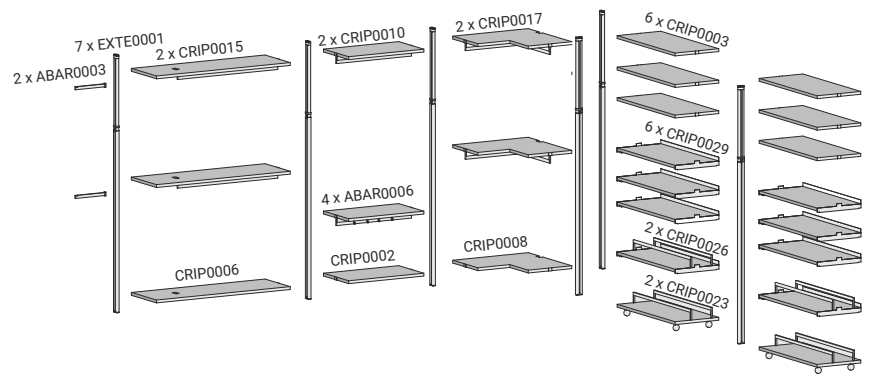
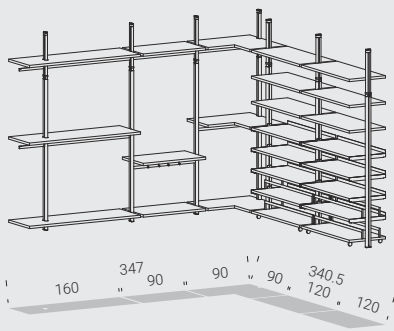

02/PERSONAL pg.420

5945 €

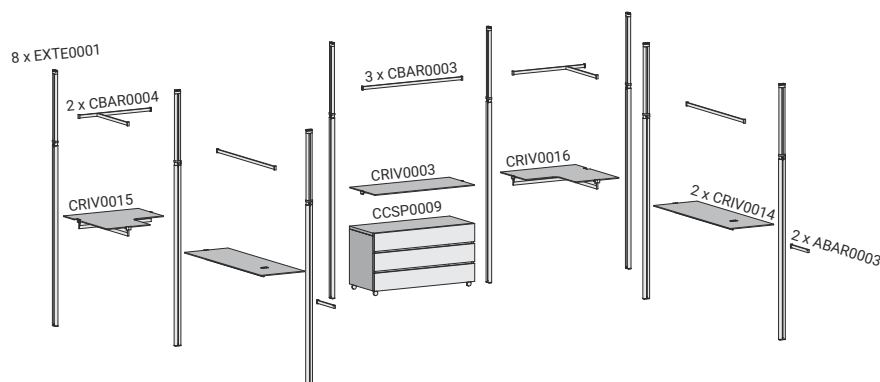
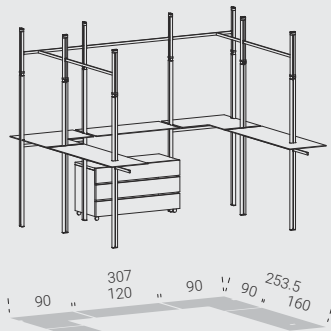

03/PERSONAL pg.424

9253 €

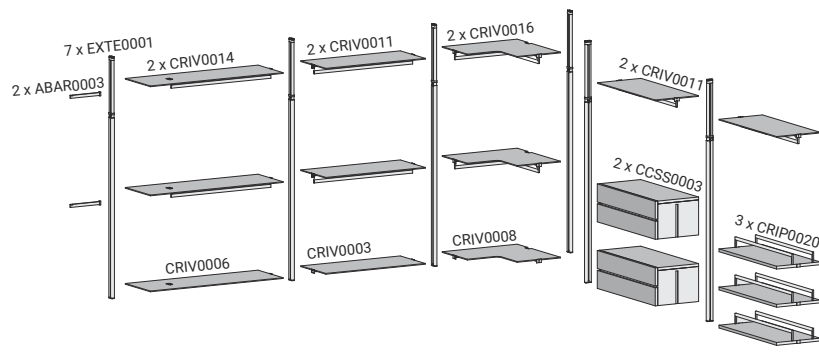
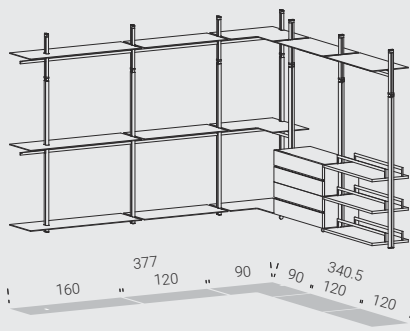



04/PERSONAL pg.428

6870 €

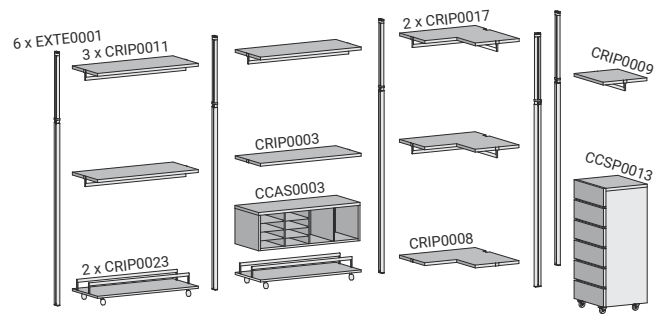
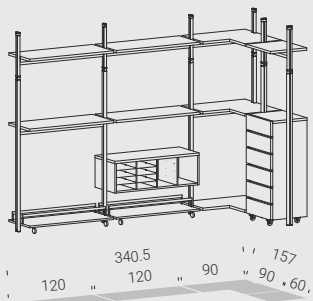

05/PERSONAL pg.430

7783 €

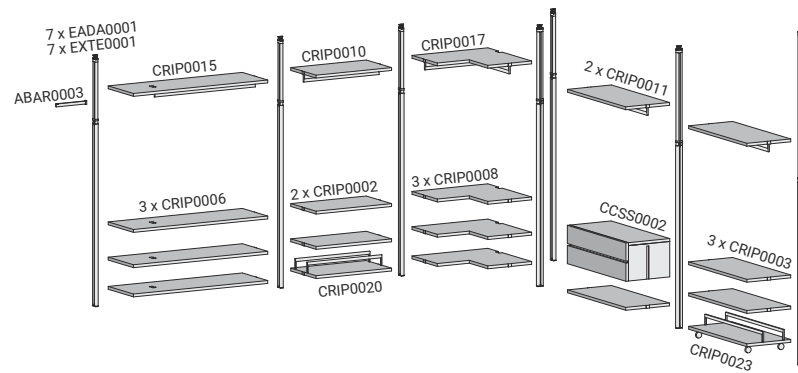
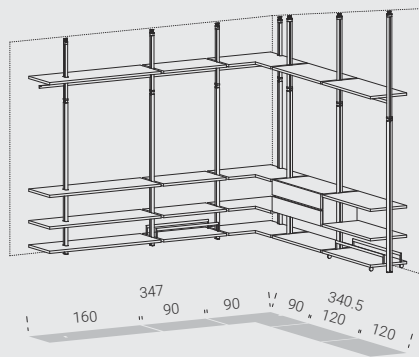

EWS

extendo wall system

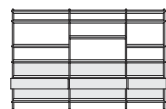

UN SISTEMA LIVING DALLE MOLTEPLICI
POSSIBILITÀ DI INSTALLAZIONE: SOSPESO A
PARETE, CON APPOGGIO A PAVIMENTO, DA
PAVIMENTO A SOFFITTO ED AUTOPORTANTE.
I PROFILI VERTICALI CONSENTONO IL
POSIZIONAMENTO IN ALTEZZA DI CONTENITORI
E RIPIANI AL CENTIMETRO. I PANNELLI
DI RIVESTIMENTO UTILIZZATI ANCHE
PARZIALMENTE POSSONO ESSERE RIMOSSI
AGEVOLMENTE PER POTER ACCEDERE AI CAVI
DI TV, IMPIANTI AUDIO, LAMPADE.

A living system with multiple installation possibilities: suspended on the wall, with or without floor support, floor standing, wall mounting and free standing. The vertical profiles allow positioning of containers and shelves to the centimetre. Any panels used can be easily removed to access TV, audio systems and lamp cables

Un système pour salon avec de multiples possibilités d'installation : suspendu au mur, avec ou sans support au sol, du sol au plafond et autoporteur. Les profils verticaux permettent de positionner les conteneurs et les étagères en hauteur, au centimètre près. Les panneaux d'embellissement utilisés, même partiellement, peuvent être facilement retirés pour accéder aux câbles des téléviseurs, systèmes audios, lampes.

Ein Living-System mit zahlreichen Montage-Möglichkeiten: hängend an der Wand, sowohl mit als auch ohne Stütze auf dem Boden, vom Boden bis zur Decke und selbsttragend. Die vertikalen Profile ermöglichen die Positionierung auf den Zentimeter der Behälter und der Einlegeböden. Die auch zum Teil verwendeten Überzugplatten können leicht entfernt werden, um zu den Kabeln von TV, Audioanlagen, Lampen zu greifen.

Un sistema con múltiples posibilidades de instalación: colgado en la pared, con o sin soporte en el suelo, de suelo a techo y autónomo. Los perfiles verticales permiten posicionar en altura los contenedores y las estanterías con una precisión de un centímetro. Los paneles de recubrimiento utilizados parcial o totalmente pueden retirarse fácilmente para acceder a los cables de la televisión, los sistemas de audio y las lámparas.





PRODUCT CONCEPT

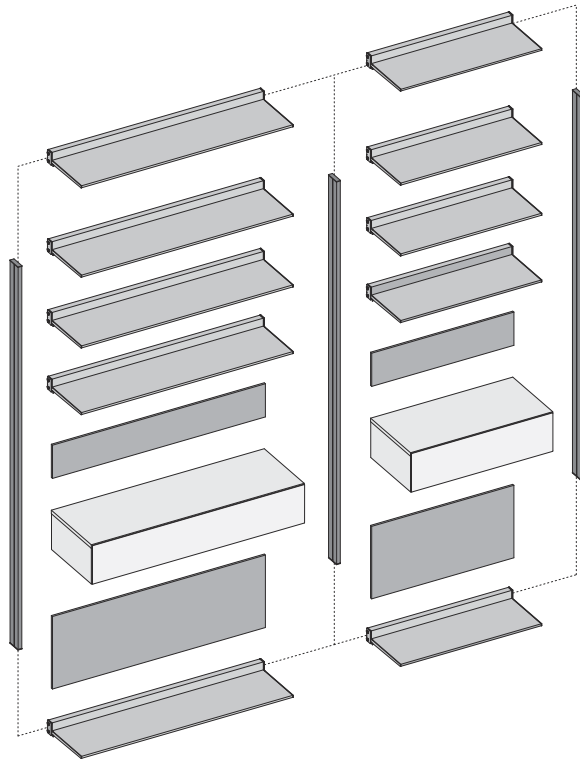

L modules
36 - 72.5 - 108.5 - 144.5

H modules
riducibile al centimetro
reducible to the centimetre
réductible au centimètre
verkürzbar auf den Zentimeter
reducible al centimetro

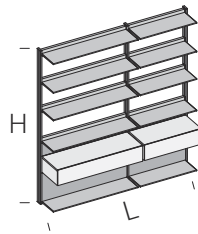

Ripiani e contenitori hanno libera posizione in altezza, (al centimetro).

Shelves and containers can be positioned at any height (to the centimetre).

Les étagères et les conteneurs peuvent être positionnés librement en hauteur (au centimètre près).

Einlegeböden und Behälter sind in der Höhe frei einsetzbar (auf den Zentimeter).

Los estantes y contenedores tienen una altura libre (al centimetro).

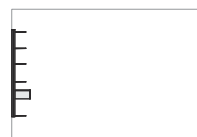

Sospeso a parete
Wall suspended
Suspendu au mur
An der Wand hängend
Montado en la pared

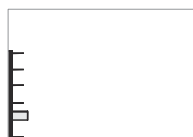

Pavimento / parete
Floor / wall
Sol / mur
Boden / Wand
Suelo / pared

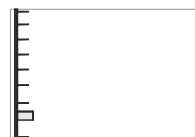

Pavimento / soffitto
Floor / ceiling
Sol / plafond
Boden / Decke
Suelo/techo

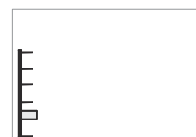

Appoggio a pavimento
Floor standing
Appui au sol
Auf den Boden stützend
Apoyado al suelo

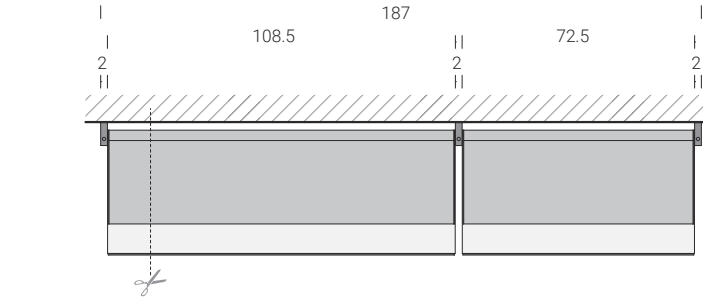
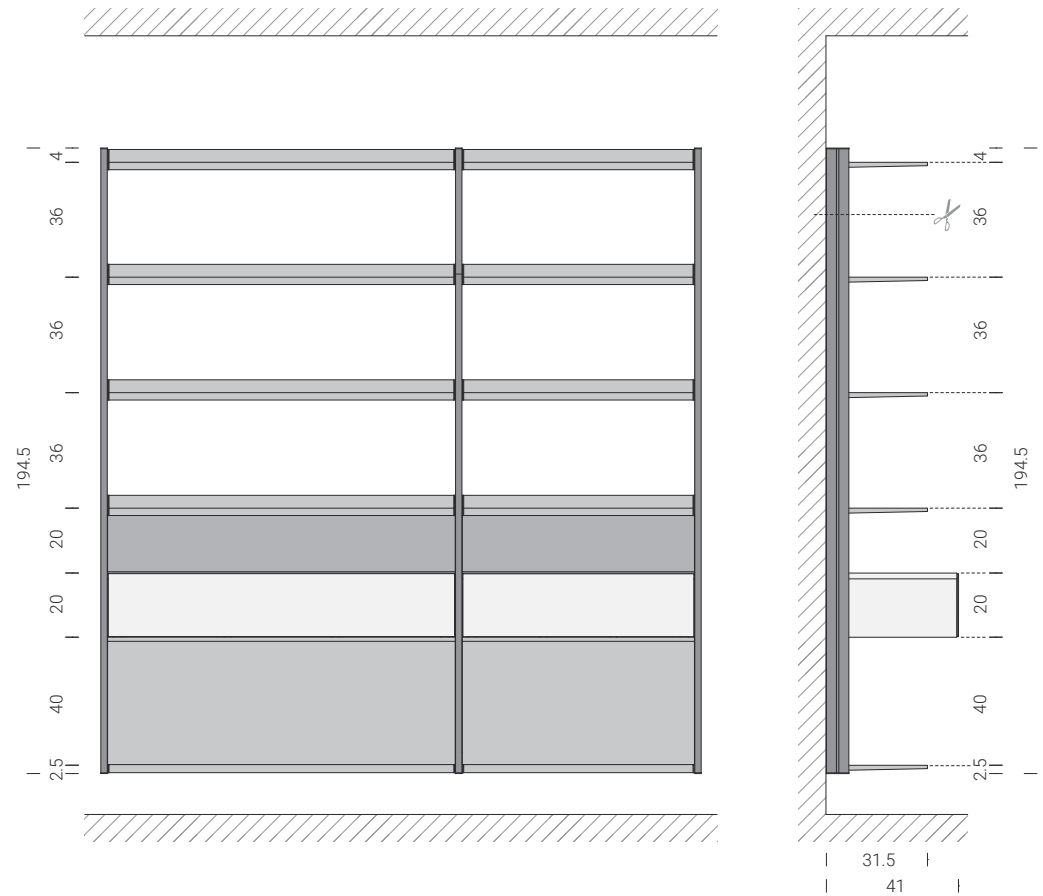

Riduzioni a misura disponibili su profili verticali, ripiani e pannelli rivestimento.

Measurement reductions available on vertical profiles, shelves and panels.

Réductions sur mesure possibles sur les profilés verticaux, les étagères et les panneaux de revêtement.

Verkürzung nach Kundenwunsch auf vertikalen Profilen, Einlegeböden und Verkleidungsplatten. Las reducciones de tamaño son posibles en los perfiles verticales, las repisas y los paneles de revestimiento.



Passacavi disponibili su pannelli rivestimento e contenitori.

Cable sleeves available on panels and containers. Passe-câbles disponibles sur les panneaux de revêtement et les conteneurs.

Kabeldurchgänge auf Verkleidungsplatten und Behälter verfügbar.

Pasacables disponibles en los paneles de revestimiento y en los contenedores.



Barre led integrate ai pannelli rivestimento.

LED light bars incorporated in the panels.

Barres DEL incorporées dans les panneaux de revêtement.

In den Verkleidungsplatten integrierte LED-Stangen.

Barras de LED integradas en los paneles de revestimiento.

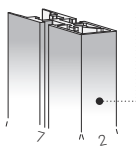

C alluminio verniciato/painted aluminium/aluminium peint
lackierter Aluminium/aluminio pintado

- C12** bianco/white
- C21** seta/silk
- C30** ghisa/cast-iron
- C08** nero/black
- C29** bronzo/bronze

**PROFILO A PARETE / WALL PROFILE / PROFILÉ MURAL
WANDPROFIL / PERFIL DE PARED**

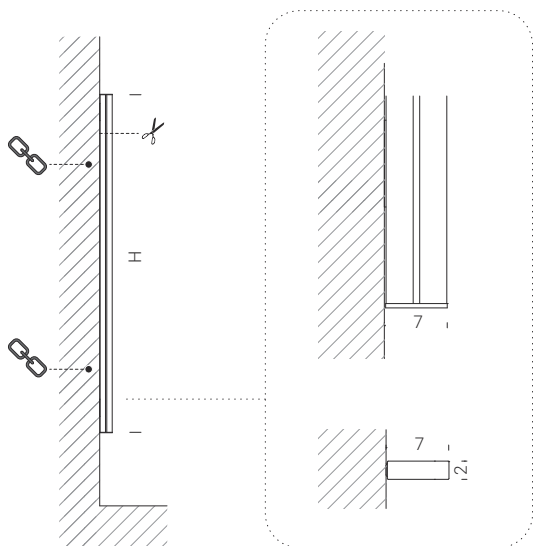

	H	C
KMON0001	160	195
KMON0001	240	240
KMON0001	290	260

**PROFILO TERRA-PARETE / GROUND-WALL PROFILE / PROFILÉ SOL-MUR
PROFIL BODEN-WAN / PERFIL SUELO-PARED**

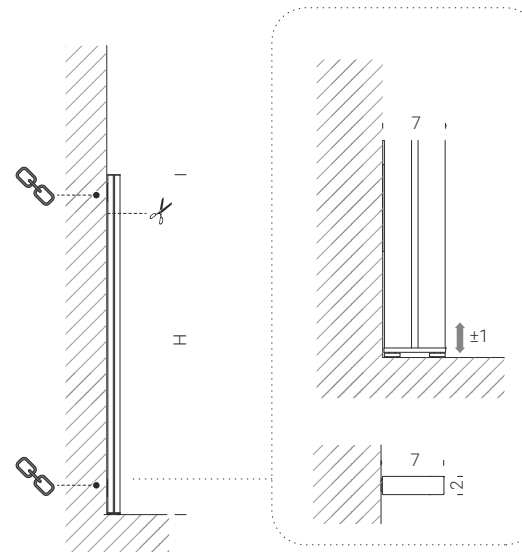

	H	C
KMON0003	160	220
KMON0003	240	260
KMON0003	290	280

**PROFILO TERRA-SOFFITTO / GROUND-CEILING PROFILE / PROFILÉ SOL-PLAFOND
PROFIL BODEN-DECKE / PERFIL SUELO-TECHO**

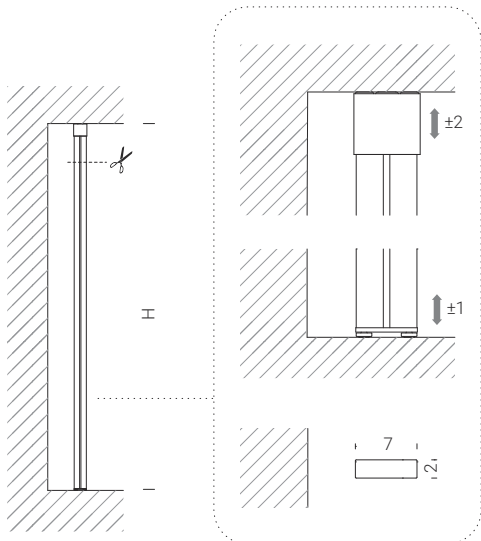

	H	C
KMON0002	290	290

**PROFILO TERRA-PARETE CON DISTANZIATORE / GROUND-WALL PROFILE WITH SPACER
PROFILÉ SOL-MUR AVEC ENTRETOISE / PROFIL BODEN-WAND MIT DISTANZSTÜCK
PERFIL SUELO-PARED CON ESPACIADOR**

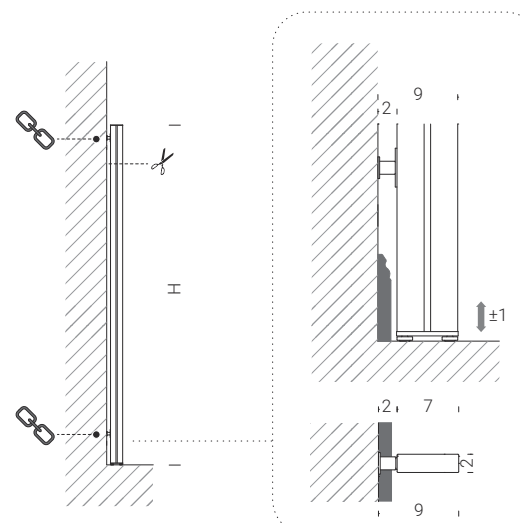

	H	C
KMON0004	160	240
KMON0004	240	280
KMON0004	290	300



disponibili riduzioni a misura
custom reductions available
Verkürzungen auf Maß erhältlich
réductions sur mesure disponibles
disponibles reducciones a medida

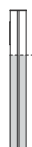

KRID0001
+30 €



fissaggio a parete obbligatorio
fixing to wall obligatory
fixation murale obligatoire
Muss an der Wand befestigt werden
fijación a la pared obligatoria

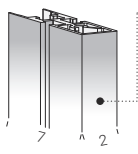

C alluminio verniciato/painted aluminium/aluminium peint lackierter Aluminium/aluminio pintado

- C12** bianco/white
- C21** seta/silk
- C30** ghisa/cast-iron
- C08** nero/black
- C29** bronzo/bronze

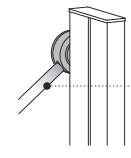

C acciaio verniciato/painted steel/acier peint lackierter Stahl/acero pintado

- C12** bianco/white
- C21** seta/silk
- C30** ghisa/cast-iron
- C08** nero/black
- C29** bronzo/bronze

**PROFILO CON BASE A PARETE / PROFILE WITH WALL BASE / PROFILÉ AVEC BASE MURALE
PROFIL MIT WANDSOCKEL / PERFIL CON BASE DE PARED**

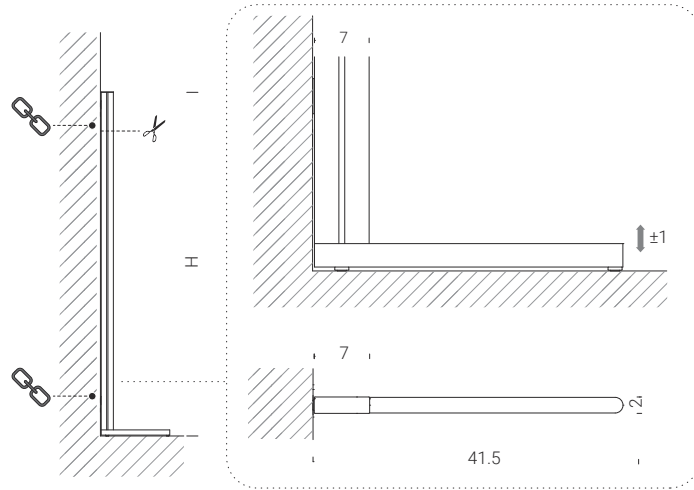

	H	C
KMON0005	160	320
KMON0005	240	360
KMON0005	290	380

**PROFILO FREE-STANDING / FREE-STANDING PROFILE / PROFILÉ AUTOPOREUR
FREI STEHENDES PROFIL / PERFIL FREE-STANDING**

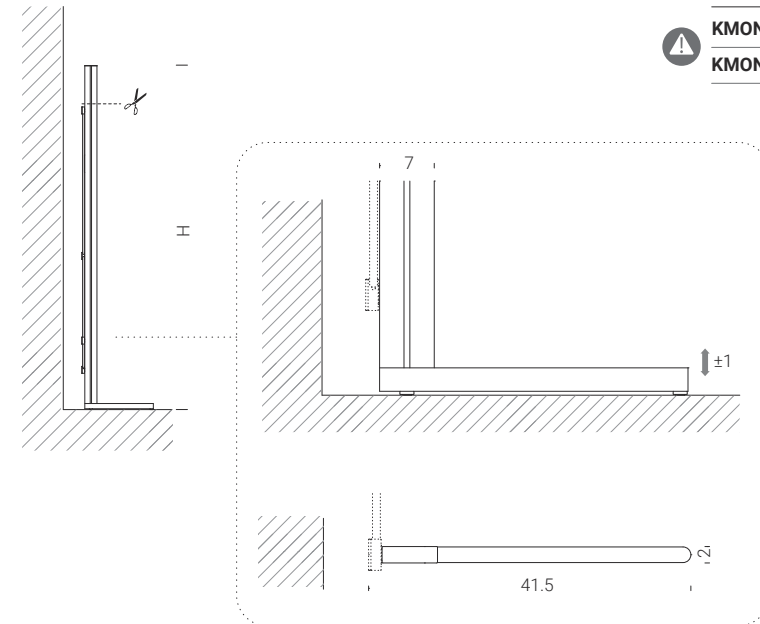

	H	C
KMON0007	160	310
KMON0007	200	340

**PROFILO CON BASE A PARETE CON DISTANZIATORE / PROFILE WITH WALL BASE AND SPACER
PROFILÉ AVEC BASE MURALE ET ENTRETOISE / PROFIL MIT WANDSOCKEL UND DISTANZSTÜCK
PERFIL CON BASE DE PARED CON ESPACIADOR**

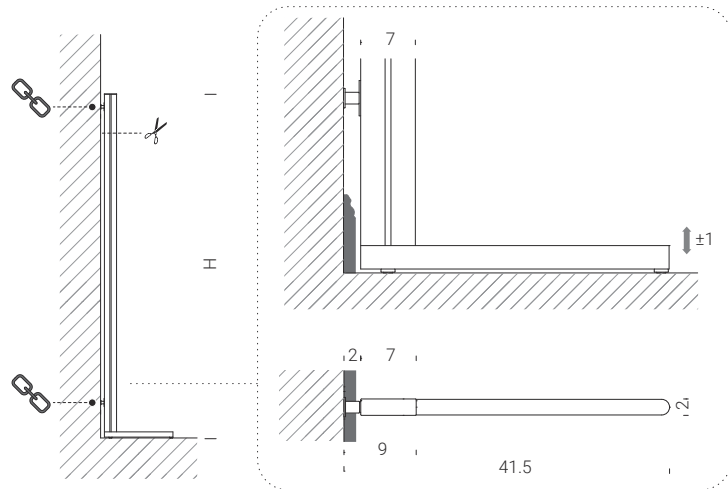

	H	C
KMON0006	160	340
KMON0006	240	380
KMON0006	290	400

TIRANTI / RODS / TIRANTS / STAHLSTANGEN / TIRANTES

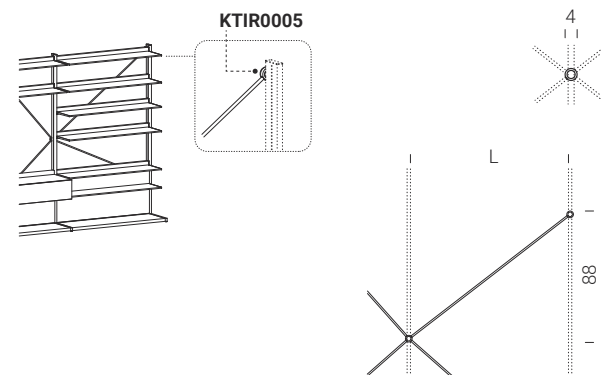

	C
KTIR0005	68

	L	C
KTIR0001	36	32
KTIR0002	72.5	34
KTIR0003	108.5	38
KTIR0004	144.5	44

disponibili riduzioni a misura
custom reductions available
Verkürzungen auf Maß erhältlich
réductions sur mesure disponibles
disponibles reducciones a medida

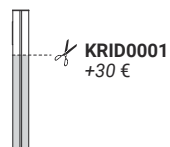

fissaggio a parete obbligatorio
fixing to wall obligatory
fixation murale obligatoire
Muss an der Wand befestigt werden
fijación a la pared obligatoria

I tiranti sono obbligatori per composizioni free standing
The tie rods are required for free standing compositions
Les tirants sont nécessaires pour les compositions autoportantes
Die Zuganker sind für freistehende Zusammensetzungen notwendig
Los tirantes son necesarios para composiciones independientes

Il raccordo può accogliere 1,2 o 4 tiranti
the joint can house 1, 2 or 4 tie rods
Le raccord peut accueillir 1, 2 ou 4 tirants
Der Anschluss kann 1, 2 oder 4 Zuganker aufnehmen
El empalme puede acoplar 1,2 ó 4 tirantes

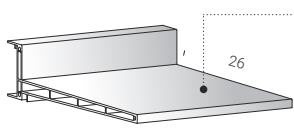

C alluminio verniciato/painted aluminium/aluminium peint lackierter Aluminium/aluminio pintado

- C12** bianco/white
- C21** seta/silk
- C30** ghisa/cast-iron
- C08** nero/black
- C29** bronzo/bronze

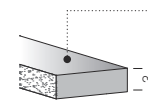

Q laccato/ lacquered/laqué lackiert/lacado

- Q05** bianco/white
- Q16** seta/silk
- Q17** corda/ecru
- Q20** ghisa/cast-iron
- Q14** antracite/anthracite
- Q04** nero/black
- Q21** bronzo/bronze

**RIPIANI IN ALLUMINIO / ALUMINIUM SHELVES / ÉTAGÈRES EN ALUMINIUM
REGALE AUS ALUMINIUM / ESTANTES DE ALUMINIO**

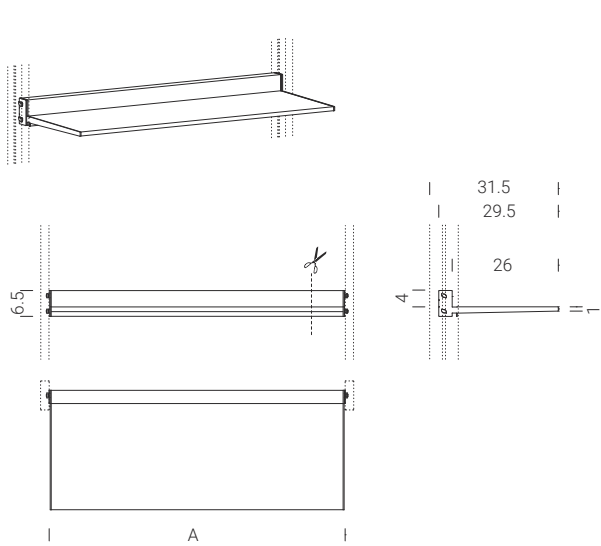

	A	kg/ml	C
KRIP0001	36	30	148
KRIP0001	72.5	30	198
KRIP0001	108.5	30	258
KRIP0001	144.5	20	298

**COPPIA DI FERMALIBRO SX-DX / LEFT AND RIGHT BOOKENDS
PAIRE DE SERRE-LIVRES GAUCHEDROITE / BUCHSTÜTZENPAAR LI-RE
PAREJA DE SUJETALIBROS SX-DX**

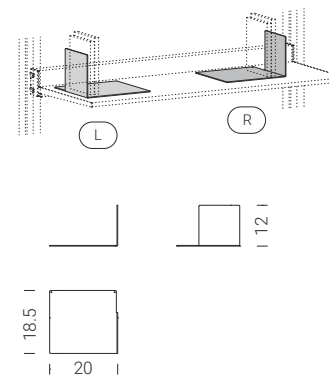

	C
KACC0001	78

set di due (L+R)
set of two (L+R)

RIPIANI A PARETE / WALL SHELVES / TABLETTES MURALS / WANDREGALE / ESTANTES A PARED

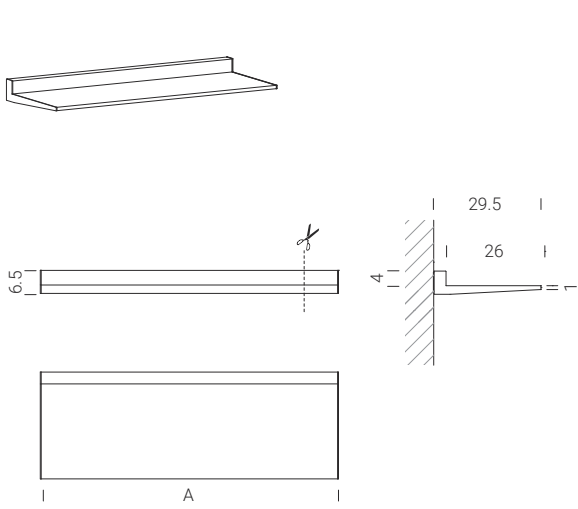

	L	kg/ml	C
KRIP0002	80	20	215
KRIP0002	120	20	298
KRIP0002	160	20	351
KRIP0002	200	20	493
KRIP0002	240	20	517
KRIP0002	280	20	530
KRIP0002	300	20	558

BASE / BASE / BASE / BASIS / BASE

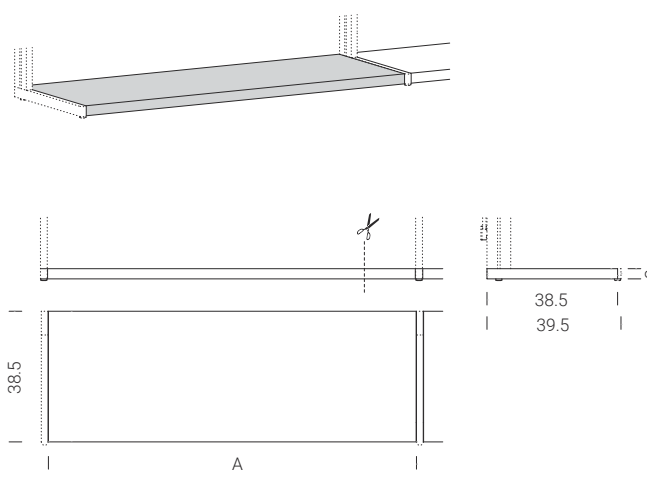

	A x 38.5	Q
KACC0003	36 x 38.5	136
KACC0004	72.5 x 38.5	172
KACC0005	108.5 x 38.5	197
KACC0006	144.5 x 38.5	239

disponibili riduzioni a misura
custom reductions available
réductions sur mesure disponibles
Verkürzungen auf Maß erhältlich
disponibles reducciones a medida

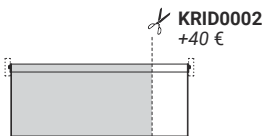

Q laccato/lacquered/laqué
lackiert/lacado

Y essenza/wood/bois
Holz/madera

X laccato metallo/metal lacquered
laqué metal/Metalllackierung
lacado metal

Q05 bianco/white
Q16 seta/silk
Q17 corda/ecru
Q20 ghisa/cast-iron
Q14 antracite/anthracite
Q04 nero/black
Q21 bronzo/bronze

Y36 rovere/oak
Y34 noce/walnut
Y37 rovere affumicato/smoked oak
Y38 rovere nero/black oak
Y40 frassino argilla/clay ash

X01 rame/copper
X02 ottone/brass
X03 titanio/titanium

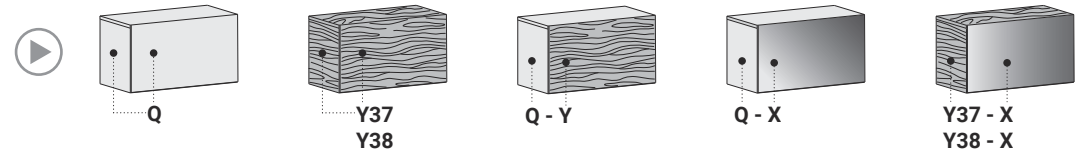

ANTA RIBALTA / FLAP DOOR / PORTE A ABATTANT / KLAPPTÜR / PUERTA ABATIBLE

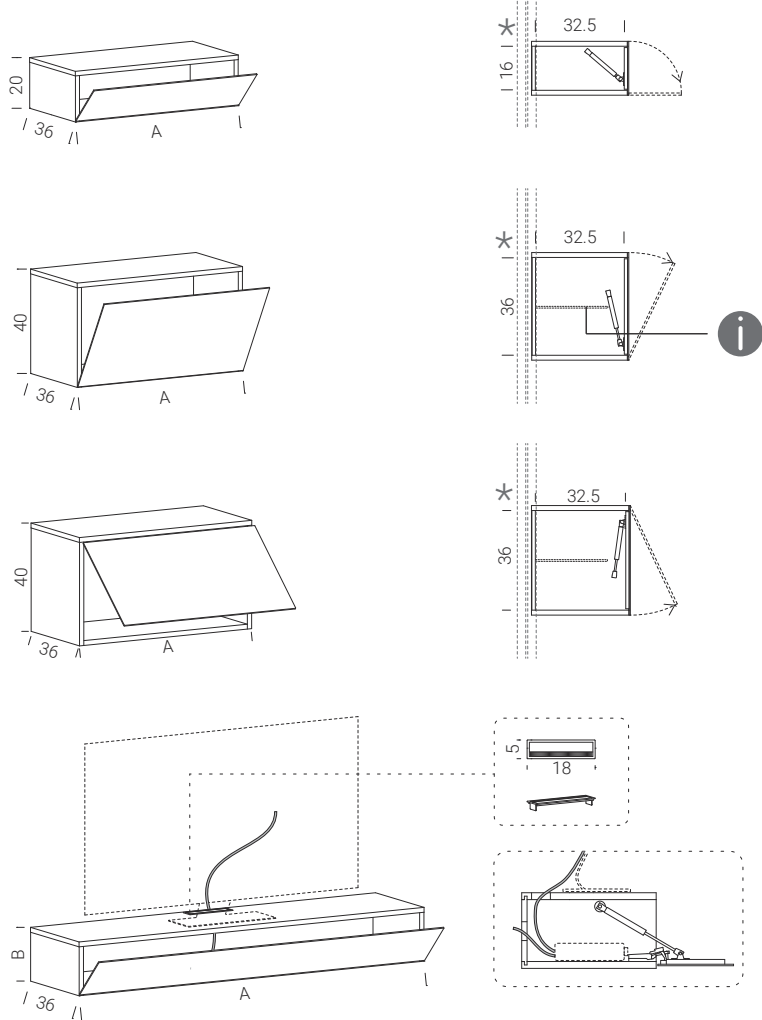

	A x 20	kg max	Q	Y37 Y38	Q-Y	Q-X	Y37-X Y38-X
KCAR0001	72.5 x 20	25	657	914	749	684	849
KCAR0002	108.5 x 20	30	776	1079	885	808	1002
KCAR0003	144.5 x 20	30	873	1213	995	908	1126

	A x 40	kg max	Q	Y37 Y38	Q-Y	Q-X	Y37-X Y38-X
KCAR0004	36 x 40	20	554	771	632	577	716
KCAR0005	72.5 x 40	25	738	1026	841	768	953
KCAR0006	108.5 x 40	30	887	1233	1011	923	1145
KCAR0007	144.5 x 40	30	1008	1402	1149	1049	1302

	A x 40	kg max	Q	Y37 Y38	Q-Y	Q-X	Y37-X Y38-X
KCAR0008	36 x 40	20	554	771	632	577	716
KCAR0009	72.5 x 40	25	738	1026	841	768	953
KCAR0010	108.5 x 40	30	887	1233	1011	923	1145

	A x B	kg max	Q	Y37 Y38	Q-Y	Q-X	Y37-X Y38-X
KCAR0011	72.5 x 20	25	670	932	764	697	865
KCAR0012	108.5 x 20	30	805	1119	918	837	1038
KCAR0013	144.5 x 20	30	1004	1395	1144	1044	1295
KCAR0014	72.5 x 40	25	804	1118	917	836	1037
KCAR0015	108.5 x 40	30	1008	1401	1149	1048	1300
KCAR0016	144.5 x 40	30	1139	1583	1299	1185	1469

il contenitore prevede il passaggio cavi come da schema
the container incorporates the cable sleeve as shown in the diagram
le conteneur prévoit le passage des câbles comme indiqué sur le schéma
Der Turm sieht den Kabeldurchgang laut Schema vor
el contenedor prevé el paso de cables según el esquema

*
dimensioni interne
internal dimensions
dimensions internes
Innenmaße
dimensiones internas

i
ripianti interni non inclusi
internal shelves not included
étagères internes non incluses
Interne Einlegeböden nicht enthalten
estantes internos no incluidos

▶
Dettaglio anta
Detail of a door
Détail de la porte
Türdetail
Detalle de la puerta

Q laccato/lacquered/laqué
lackiert/lacado

Y essenza/wood/bois
Holz/madera

X laccato metallo/metal lacquered
laqué metal/Metallackierung
lacado metal

Q05 bianco/white
Q16 seta/silk
Q17 corda/ecru
Q20 ghisa/cast-iron
Q14 antracite/anthracite
Q04 nero/black
Q21 bronzo/bronze

Y36 rovere/oak
Y34 noce/walnut
Y37 rovere affumicato/smoked oak
Y38 rovere nero/black oak
Y40 frassino argilla/clay ash

X01 rame/copper
X02 ottone/brass
X03 titanio/titanium

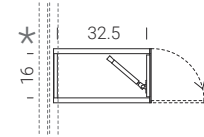
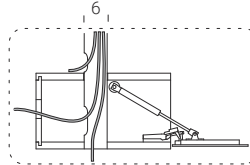
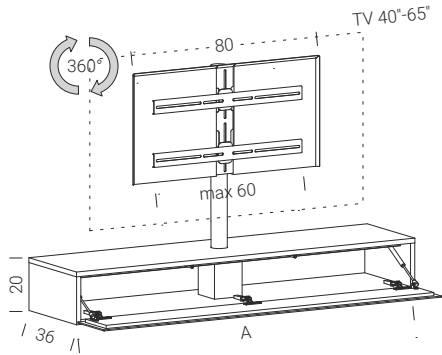
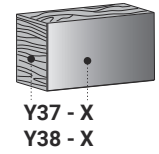
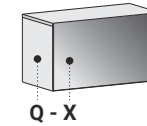
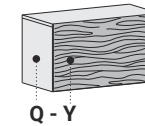
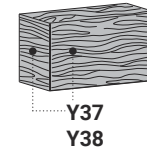
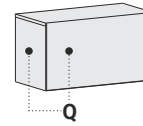

	A x 20	kg max	Q	Y37 Y38	Q-Y	Q-X	Y37-X Y38-X
KCAR0017	108.5 x 20	30	1098	1527	1252	1142	1417
KCAR0018	144.5 x 20	30	1346	1871	1534	1400	1737



supporto monitor universale per TV da 40 a 65 pollici.
universal monitor support for TV from 40 to 65 inches.
support moniteur universel pour TV de 40 à 65 pouces.
Universal-Monitor-Halter für TV von 40 bis 65 Zoll.
soporte de monitor universal para TV de 40 a 65 pulgadas.

ANTE BATTENTE / LEAF DOOR UNITS / PORTE À BATTANT / FLÜGELTÜR / PUERTA BATIENTE

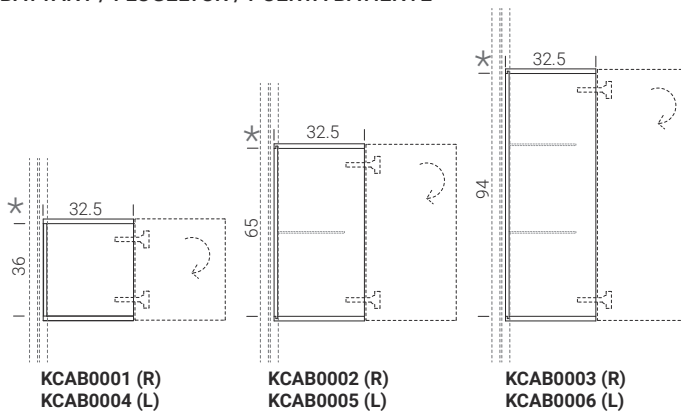
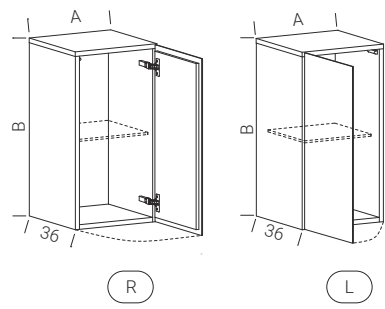

	A x B	kg max	Q	Y37 Y38	Q-Y	Q-X	Y37-X Y38-X
(R) KCAB0001	36 x 40	25	514	714	586	534	662
(R) KCAB0002	36 x 69	25	609	847	695	634	786
(R) KCAB0003	36 x 98	25	704	979	803	733	909
(L) KCAB0004	36 x 40	25	526	731	600	547	678
(L) KCAB0005	36 x 69	25	610	848	695	634	787
(L) KCAB0006	36 x 98	25	704	979	803	733	909

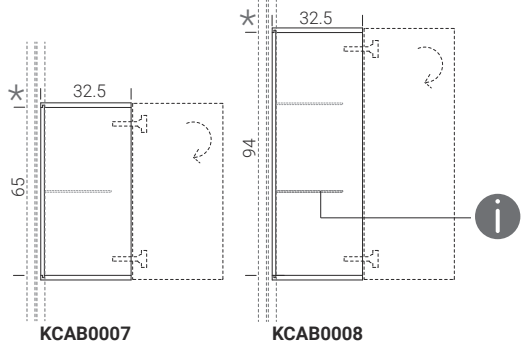
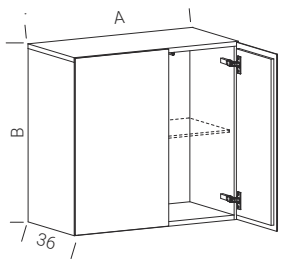

	A x B	kg max	Q	Y37 Y38	Q-Y	Q-X	Y37-X Y38-X
KCAB0007	72.5 x 69	25	840	1168	958	874	1084
KCAB0008	72.5 x 98	25	869	1208	991	904	1121

*
dimensioni interne
internal dimensions
dimensions internes
Innenmaße
dimensiones internas

i
ripiani interni non inclusi
internal shelves not included
étagères internes non incluses
Interne Einlegeböden nicht enthalten
estantes internos no incluidos

Q laccato/lacquered/laqué
lackiert/lacado

Y essenza/wood/bois
Holz/madera

X laccato metallo/metal lacquered
laqué metal/Metalllackierung
lacado metal

Q05 bianco/white
Q16 seta/silk
Q17 corda/ecru
Q20 ghisa/cast-iron
Q14 antracite/anthracite
Q04 nero/black
Q21 bronzo/bronze

Y36 rovere/oak
Y34 noce/walnut
Y37 rovere affumicato/smoked oak
Y38 rovere nero/black oak
Y40 frassino argilla/clay ash

X01 rame/copper
X02 ottone/brass
X03 titanio/titanium

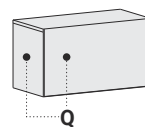

Q

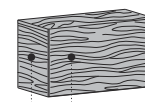

Y37
Y38

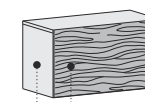

Q - Y

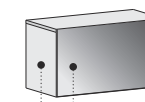

Q - X

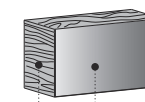

Y37 - X
Y38 - X

RIPIANI / SHELVES / ÉTAGÈRES / BÖDEN / ESTANTES

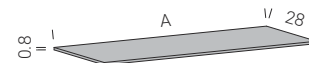
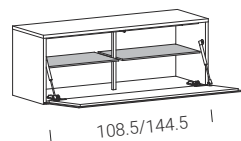
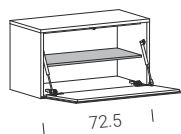
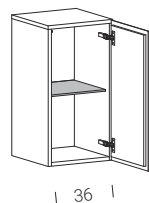

	A x 28	V07
ARIV0035	36 x 28	54
ARIV0036	72.5 x 28	63
! ARIV0039	108.5 x 28	95
! ARIV0040	144.5 x 28	110

forature per supporti ripiano da eseguire in opera Ø5 mm
holes for shelf supports to be drilled Ø5 mm
trous pour supports d'étagères à réaliser sur place Ø5 mm
Löcher für Einlegebodenhalter sind mit Ø5 mm vorzunehmen
orificios para soportes de baldas a realizar in situ Ø5 mm

PASSACAVO / CABLE TIDY / PASSE-CÂBLES / KABELDURCHFÜHRUNG / PASACABLES

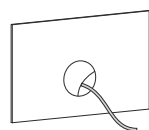

7

	C04 C08
XACC0014	8

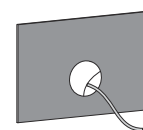

7

	C04 C08
XACC0028	60

La foratura è da eseguire in opera/holes are to be made during installation/le perçage est à effectuer lors du montage
Die Bohrung ist bei der Montage anzubringen/el perforado debe llevarse a cabo durante la instalación

passacavo con servizio di foratura/cable duct with perforation service/passe-câbles avec service de perçage
Kabeldurchführung mit Bohrmöglichkeit/pasacable con servicio de perforado

CASSETTIERE / DRAWERS UNITS / KITS DE TIROIRS / SCHUBLADENELEMENTE / CAJONERAS

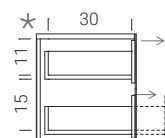
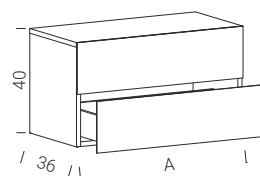
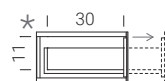
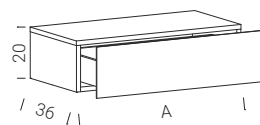

	A x 20	kg max	Q	Y37 Y38	Q-Y	Q-X	Y37-X Y38-X
KCSS0001	36 x 20	25	477	663	544	496	615
KCSS0002	72.5 x 20	25	590	820	672	614	762
KCSS0003	108.5 x 20	25	698	970	796	726	900

	A x 40	kg max	Q	Y37 Y38	Q-Y	Q-X	Y37-X Y38-X
KCSS0004	36 x 40	25	633	880	721	658	817
KCSS0005	72.5 x 40	25	794	1103	905	826	1024
KCSS0006	108.5 x 40	25	972	1351	1108	1011	1254

*
dimensioni interne
internal dimensions
dimensions internes
Innenmaße
dimensiones internas

!
il codice prevede una coppia di ripiani
the code includes two shelves
le code prévoit deux étagères
Artikelnummer sieht ein Einlegebodenpaar vor
el código prevé un par de estantes

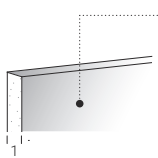

Q MDF laccato/lacquered MDF/MDF laqué
lackiert MDF/MDF lacado

- Q05** bianco/white
- Q16** seta/silk
- Q17** corda/ecru
- Q20** ghisa/cast-iron
- Q14** antracite/anthracite
- Q04** nero/black
- Q21** bronzo/bronze

Y MDF legno/MDF wood/MDF bois
MDF Holz/DM madera

- Y36** rovere/oak
- Y34** noce/walnut
- Y37** rovere affumicato/smoked oak
- Y39** rovere nero/black oak
- Y40** frassino argilla/clay ash

PANNELLO BOISERIE / BOISERIE PANEL / PANNEAU EN BOISERIE / TÄFELUNGSPLATTE / PANEL BOISERIE

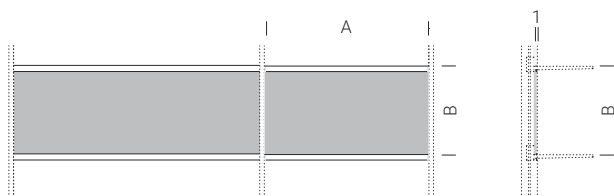
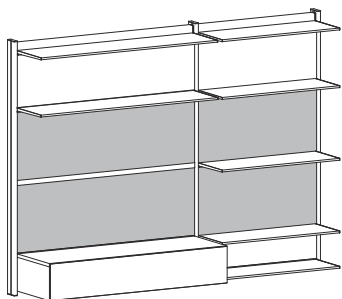

	A x B	Q	Y
KSIL0001	36 x 20	57	67
KSIL0002	72.5 x 20	79	98
KSIL0003	108.5 x 20	109	138
KSIL0004	144.5 x 20	132	171
KSIL0005	36 x 29	65	80
KSIL0006	72.5 x 29	92	121
KSIL0007	108.5 x 29	127	171
KSIL0008	144.5 x 29	156	215
KSIL0009	36 x 40	74	96
KSIL0010	72.5 x 40	108	150
KSIL0011	108.5 x 40	150	213
KSIL0012	144.5 x 40	185	270

**PANNELLO BOISERIE CON PASSACAVO / BOISERIE PANEL WITH CABLE SLEEVES / PANNEAU EN BOISERIE AVEC PASSAGE DE CABLES
TÄFELUNGSPLATTE MIT KABELDURCHGANG / PANEL BOISERIE CON PASACABLE**

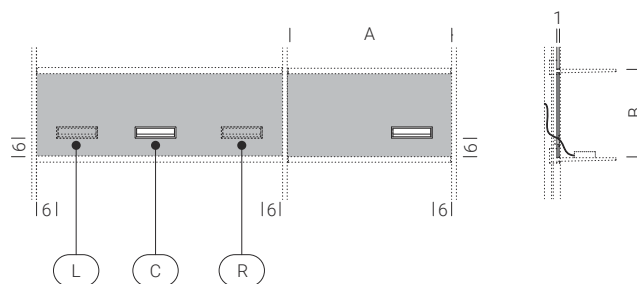
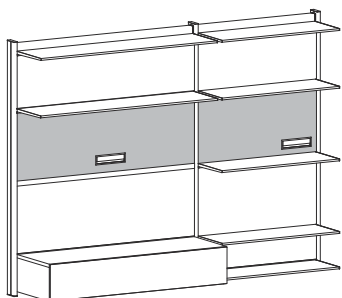

ordinabile in posizione L (sinistra), R (destra), C (centrale).
available in the following positions: L (left), R (right), C (central).
peut être commandé en position L (gauche), R (droite), C (centrale).
aufstellbar in Position L (links), R (rechts), C (Mitte).
disponible en posición L (izquierda), R (derecha), C (central).

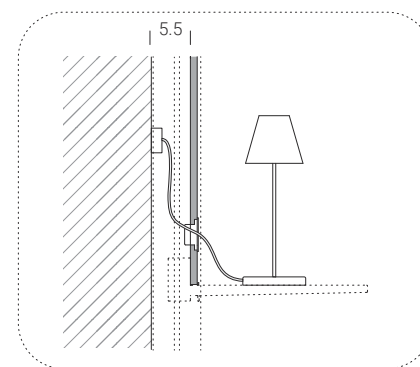

	A x B	Q	Y
KSIL0013	36 x 20	129	139
KSIL0014	72.5 x 20	151	170
KSIL0015	108.5 x 20	181	210
KSIL0016	144.5 x 20	204	243
KSIL0017	36 x 29	137	152
KSIL0018	72.5 x 29	164	193
KSIL0019	108.5 x 29	199	243
KSIL0020	144.5 x 29	228	287
KSIL0021	36 x 40	146	168
KSIL0022	72.5 x 40	180	222
KSIL0023	108.5 x 40	222	285
KSIL0024	144.5 x 40	257	342



disponibili riduzioni a misura (prezzo per 1 taglio)
custom reductions available (price for 1 cut)
réductions sur mesure disponibles (prix pour 1 coupe)
Verkürzungen auf Maß erhältlich (Preis für 1 Schnitt)
disponibles reducciones a medida (precio por 1 corte)

KRID0003
+30 €



KRID0003
+30 €



Pannello boiserie
Boiserie panel
Panneau en boiserie
Täfelungsplatte
Panel boiserie

- L** HPL
HPL POLARIS®
L03 bianco/white
L10 grigio chiaro/light grey
L11 grigio scuro/dark grey
HPL FENIX®
L08 grigio Londra/London grey
L06 nero/black

- Q** HPL laccato/lacquered HPL/HPL laqué
lackiert HPL/HPL lacado
Q16 seta/silk
Q17 corda/ecru
Q20 ghisa/cast-iron
Q14 antracite/anthracite
Q21 bronzo/bronze

- Q** MDF laccato/lacquered MDF/MDF laqué
lackiert MDF/MDF lacado
Q05 bianco/white
Q16 seta/silk
Q17 corda/ecru
Q20 ghisa/cast-iron
Q14 antracite/anthracite
Q04 nero/black
Q21 bronzo/bronze

- Y** MDF legno/MDF wood/MDF bois
MDF Holz/DM madera
Y36 rovere/oak
Y34 noce/walnut
Y37 rovere affumicato/smoked oak
Y39 rovere nero/black oak
Y40 frassino argilla/clay ash

BARRE LED / LED LIGHT BARS / BARRES LED / LED-LEISTEN / BARRAS LED

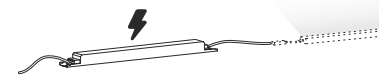
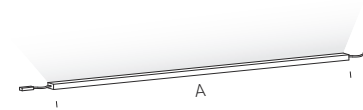
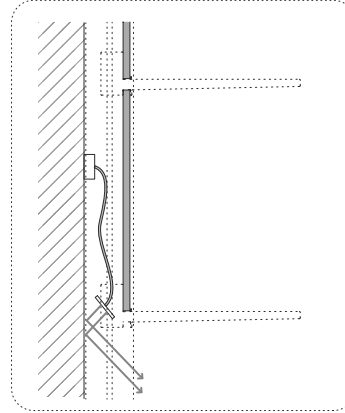
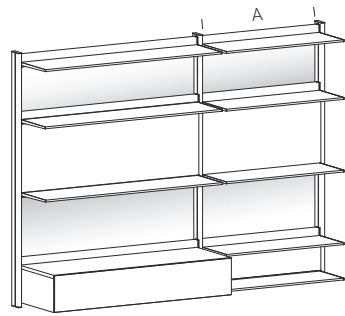

	A	WATT	
KACC0007	36	4	68
KACC0008	72.5	7	80
KACC0009	108.5	11	92
KACC0010	144.5	14	98

	WATT	
KACC0011	60	240
KACC0012	100	285

barre LED per illuminare la parete verso l'alto o verso il basso, posizionabili sul retro di contenitori o pannelli schiena.
LED light bars to illuminate the wall towards the ceiling and floor, positionable on the back of containers or back panels.
barres LED pour éclairer le mur vers le haut ou vers le bas, à positionner à l'arrière des conteneurs ou des panneaux de dossier.
LED-Leisten zur Wandbeleuchtung nach oben oder unten, an der Turmrückseite oder an Rückseitenplatten positionierbar.
barras LED para iluminar la pared hacia arriba o hacia abajo, que se pueden colocar en la parte posterior de contenedores o trasera de los paneles

TOP SCRIVANIA / DESKTOP / PLATEAU DE BUREAU / SCHREIBTISCH / ESCRITORIO

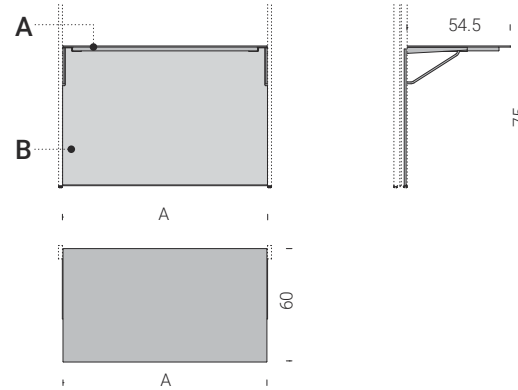
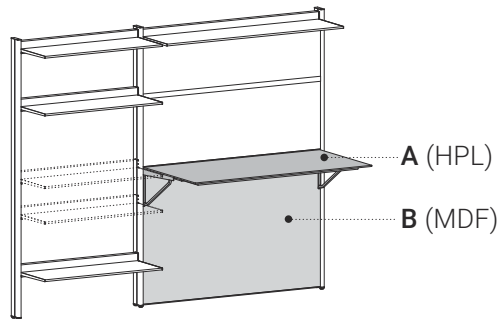

A	A x 60	kg/ml	L03	L08	Q
			L06	L11	
KRIP0003	72.5 x 60	25	541	573	519
KRIP0004	108.5 x 60	25	657	704	623
KRIP0005	144.5 x 60	25	767	830	720

B	A x 75	Q	Y	
			L03	L11
KSIL0025	72.5 x 75	138	215	
KSIL0026	108.5 x 75	187	302	
KSIL0027	144.5 x 75	241	356	

**COPPIA STAFFE SUPPORTO MONITOR ROTANTI / PAIR OF ROTATING MONITOR SUPPORT RODS / DEUX ÉTRIERS DE SUPPORT ÉCRAN ROTATIFS
PAAR DREHHALTERUNGEN MONITORTRÄGER / PAR DE FIJACIONES GIRATORIAS PARA SOPORTE MONITOR**

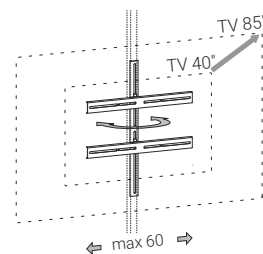
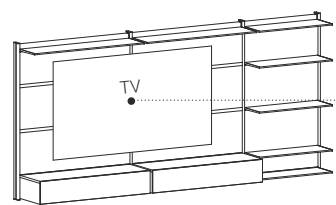

KACC0002	220
-----------------	-----

ATELIER



ATELIER È CONFIGURABILE UTILIZZANDO MODULI IN ACCIAIO CON SEZIONE MINIMA DI 10X10MM E CONTENITORI IN LEGNO CON DIVERSE TIPOLOGIE DI APERTURE. TELAI E CONTENITORI POSSONO ESSERE SOVRAPPosti E AFFIANCATI A PIACIMENTO, POSIZIONATI SU BASI O SOSPESI A PARETE. SONO DISPONIBILI ACCESSORI DA INSERIRE ALL'INTERNO DEI TELAI E TOP IN HPL O CERAMICA.

Atelier can be configured using modular elements in steel with a minimum 10x10mm cross-section as well as wooden containers with several different types of openings. Both frames and containers can be stacked and placed side by side as desired, either installed onto support bases or wall-mounted. Accessories to be integrated into the frames and tops in HPL or ceramic.

Atelier peut être configuré en utilisant des modules en acier avec une section minimum de 10x10 mm et des bacs en bois avec plusieurs typologies d'ouvertures. Châssis et bacs peuvent être superposés et associés à loisir, positionnés sur des bases ou suspendus au mur. Des accessoires sont disponibles pour l'insertion à l'intérieur des châssis et plateau en HPL ou céramique.

Bei der modularen Serie Atelier lassen sich Stahlmodule mit einer Mindeststärke von 10x10 mm mit Holzbehältern verschiedener Arten und Öffnungen kombinieren. Gestelle und Behälter können übereinander oder nebeneinander angeordnet, auf einen Unterbau gestellt oder an der Wand aufgehängt werden. Verschiedene Einsätze für die Gestelle sowie Abschlussplatten aus HPL oder Keramik als Zubehör erhältlich.

Atelier se puede configurar utilizando módulos de acero con sección mínima de 10x10mm, así como contenedores de madera con distintos tipos de aperturas. Bastidores y contenedores, pueden colocarse uno encima del otro o uno al lado del otro, según se prefiera, posicionados sobre bases o colgados en la pared. Están disponibles accesorios que se pueden introducir en el interior de los bastidores y encimeras de laminado de alta presión (HPL) o cerámico.





PRODUCT CONCEPT

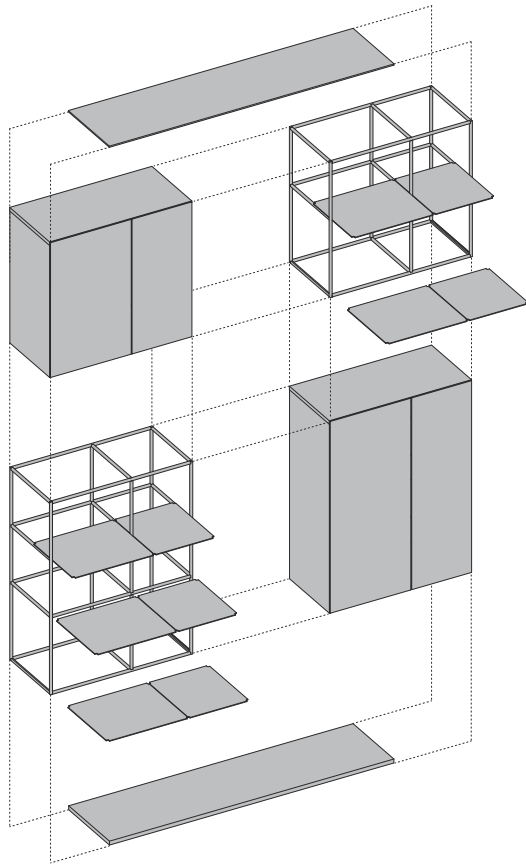

L modules
36 - 72.5 - 108.5

H modules
20 - 29 - 40 - 69 - 98

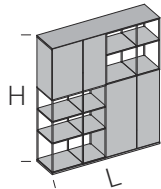

I moduli si affiancano e sovrappongono liberamente.
The modules can be positioned side-by-side or overlapped as desired.
Les modules se positionnent les uns à côté des autres et se superposent librement.
Die Module können nebeneinander und übereinander frei montiert werden.
Los módulos pueden colocarse uno al lado del otro y superponerse libremente.

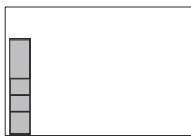

Pavimento / parete
Floor / wall
Sol / mur
Boden / Wand
Suelo / pared

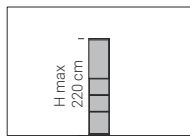

Bifacciale
Double-sided
Double face
Zweiseitig
Doble cara

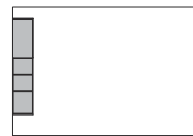

Sospeso a parete
Suspended on the wall
Suspendu au mur
An der Wand hängend
Montado en la pared

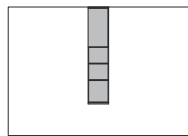

Sospeso a soffitto
Ceiling-suspended
Suspendu au plafond
An der Decke hängend
Suspendido en el techo

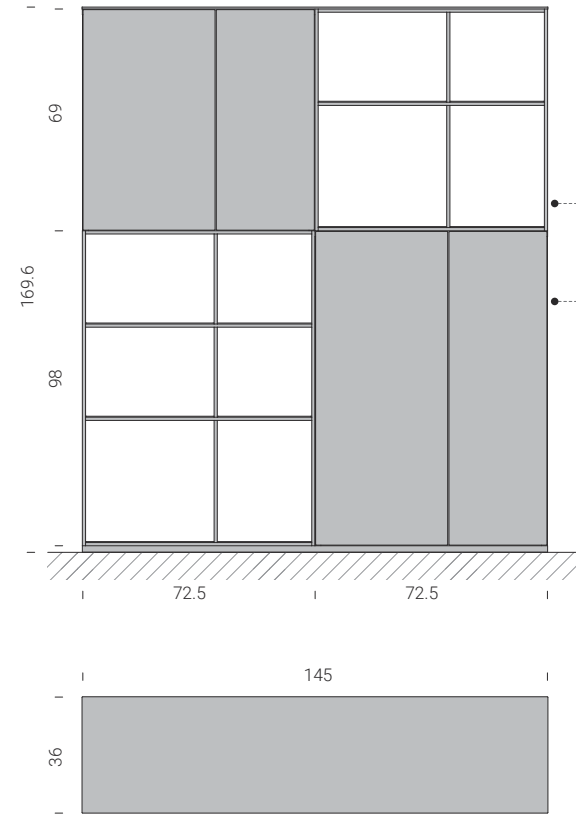

non riducibili
non-reducible items
aucune réduction possible
nicht verkürzbar
no reducibles

i è possibile sovrapporre e affiancare telai e contenitori la cui somma delle lunghezze e altezze sia coincidente (es. 72.5+36=108.5 cm)
it is possible to place frames and containers on top of each other if the sum of their lengths is the same (e.g. 72.5+36=108.5 cm)
il est possible de superposer les bâtis et les espaces de rangement dont la somme des longueurs coïncide (ex. 72,5+36=108,5 cm)
Rahmen und Behälter, deren Gesamtlängen zusammenfallen (z. B. 72,5 + 36 = 108,5 cm), können überlagert werden
es posible superponer marcos y contenedores cuya suma de las longitudes es la misma (por ejemplo, 72,5 + 36 = 108,5 cm)

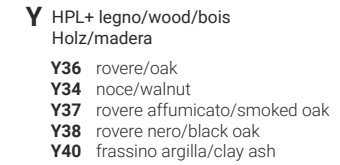
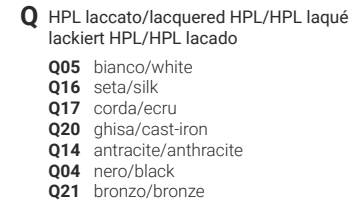
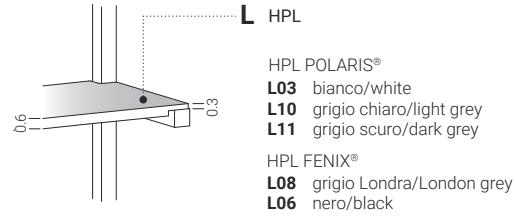
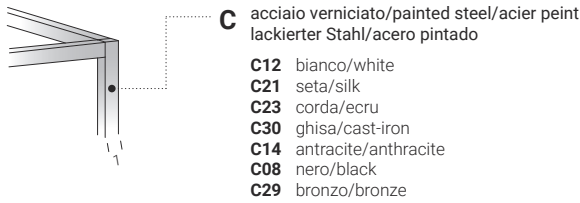

MODULI 36 / MODULES 36 / MODULES 36 / MODULE 36 / MÓDULOS 36

		Q	L03 L06	L08 L10 L11	Y	☁			
			VSTR0021	36 x 20	219	226	235	253	+40
			VSTR0023	36 x 20	244	252	261	281	+40
			VSTR0025	36 x 29	229	237	246	265	+40
			VSTR0028	36 x 29	256	264	274	295	+40
			VSTR0022	36 x 40	242	250	259	279	+40
			VSTR0024	36 x 40	267	275	286	308	+40
			VSTR0005	36 x 69	364	375	389	420	+40
			VSTR0015	36 x 69	379	391	406	437	+40
			VSTR0008	36 x 98	476	491	509	549	+40
			VSTR0018	36 x 98	494	510	529	570	+40

MODULI 72.5 / MODULES 72.5 / MODULES 72.5 / MODULE 72.5 / MÓDULOS 72.5

		Q	L03 L06	L08 L10 L11	Y	☁			
			VSTR0001	72.5 x 20	362	373	387	417	+40
			VSTR0011	72.5 x 20	397	409	425	458	+40
			VSTR0026	72.5 x 29	372	384	398	429	+40
			VSTR0029	72.5 x 29	408	421	437	471	+40
			VSTR0003	72.5 x 40	379	391	406	438	+40
			VSTR0013	72.5 x 40	413	426	442	477	+40
			VSTR0006	72.5 x 69	609	628	652	703	+40
			VSTR0016	72.5 x 69	637	657	682	735	+40
			VSTR0009	72.5 x 98	857	884	918	989	+50
			VSTR0019	72.5 x 98	862	889	923	995	+50



maggiorazione per
surcharge for
majoration pour
Zuschlag für
aumento para

esterno riparato **L03, L06, L08, L10, L11**
sheltered outdoor **L03, L06, L08, L10, L11**
extérieur protégé **L03, L06, L08, L10, L11**
draußen geschützt **L03, L06, L08, L10, L11**
exterior reparado **L03, L06, L08, L10, L11**



moduli utilizzabili anche per ancoraggio a soffitto
modules that can also be used for ceiling fixing
les modules peuvent également être utilisés avec ancrage au plafond
Auch für Deckenbefestigung verwendbare Module
módulos utilizables también para anclaje al techo

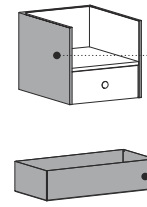

C acciaio verniciato/painted steel
acier peint/lackierter Stahl
acero pintado

C12 bianco/white
C21 seta/silk
C23 corda/ecru
C30 ghisa/cast-iron
C14 antracite/anthracite
C08 nero/black
C29 bronzo/bronze

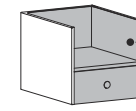

Q MDF laccato/lacquered MDF
MDF laqué/lackiert MDF
MDF lacado

Q05 bianco/white
Q16 seta/silk
Q17 corda/ecru
Q20 ghisa/cast-iron
Q14 antracite/anthracite
Q04 nero/black
Q21 bronzo/bronze



Y MDF legno/MDF wood/MDF bois
MDF Holz/DM madera

Y37 rovere affumicato/smoked oak
Y38 rovere nero/black oak

MODULI 108.5 / MODULES 108.5 / MODULES 108.5 / MODULE 108.5 / MÓDULOS 108.5

		Q	L03 L06	L08 L10 L11	Y	☁		
		VSTR0002	108.5 x 20	460	474	492	531	+40
		VSTR0027	108.5 x 29	469	483	501	523	+40
		VSTR0004	108.5 x 40	478	493	511	551	+40
		VSTR0007	108.5 x 69	852	879	912	984	+50
		VSTR0010	108.5 x 98	1206	1244	1291	1392	+60
		VSTR0020	108.5 x 98	1207	1245	1293	1393	+60

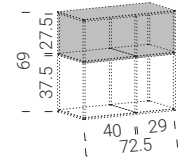
MODULI INTERNI / INTERNAL MODULES / MODULES INTERNES INTERNE MODULE / MÓDULOS INTERNOSI

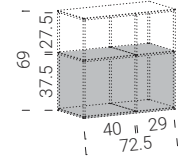
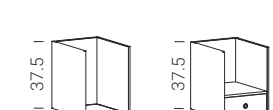
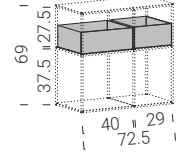
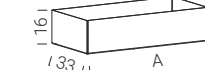
	A x B	Q	Y37 Y38
	29 x 27.5	193	244
	29 x 27.5	464	581
	29 x 37.5	216	283
	29 x 37.5	491	603
	A x B	C	☁
	28 x 33	83	+30
	39 x 33	121	+30

VERDE INTEGRATO / INTEGRATED GREEN / VERT INTÉGRÉ GRÜN INTEGRIERT / VERDE INTEGRADO

maggiorazione per
surcharge for
majoration pour
Zuschlag für
aumento para



esterno riparato **L03, L06, L08, L10, L11**
sheltered outdoor **L03, L06, L08, L10, L11**
extérieur protégé **L03, L06, L08, L10, L11**
draußen geschützt **L03, L06, L08, L10, L11**
exterior reparado **L03, L06, L08, L10, L11**



moduli utilizzabili anche per ancoraggio a soffitto
modules that can also be used for ceiling fixing
les modules peuvent également être utilisés avec ancrage au plafond
Auch für Deckenbefestigung verwendbare Module
módulos utilizables también para anclaje al techo

C acciaio verniciato/painted steel
acier peint/lackierter Stahl
acero pintado
C12 bianco/white
C08 nero/black

L HPL
HPL POLARIS®
L03 bianco/white
L10 grigio chiaro/light grey
L11 grigio scuro/dark grey
HPL FENIX®
L08 grigio Londra/London grey
L06 nero/black

Q HPL laccato/lacquered HPL/HPL laqué
lackiert HPL/HPL lacado
Q05 bianco/white
Q16 seta/silk
Q17 corda/ecru
Q20 ghisa/cast-iron
Q14 antracite/anthracite
Q04 nero/black
Q21 bronzo/bronze

Y HPL+legno/HPL+wood/HPL+bois
HPL+Holz/HPL+madera
Y36 rovere/oak
Y34 noce/walnut
Y37 rovere affumicato/smoked oak
Y39 rovere nero/black oak
Y40 frassino argilla/clay ash

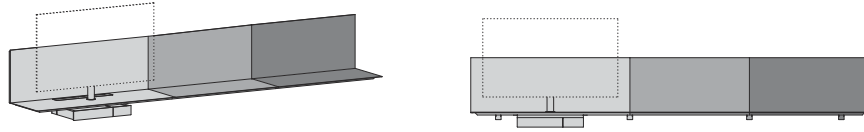

Consolle, consolle con passacavi e consolle con supporto TV possono essere affiancate per creare un'unica composizione
Console, console with cable sleeve and console with TV stand can be combined to create a single composition
Les consoles, consoles avec passage de câbles et consoles avec support TV peuvent être placées côte à côte pour créer une unique composition
Konsolen, Konsolen mit Kabeldurchgängen und Konsolen mit TV-Halterung können miteinander kombiniert werden
Consolas, consolas con pasacables y consolas con soporte para TV, se pueden unir para crear una composición única

CONSOLLE / CONSOLE / CONSOLE / KONSOLE / CONSOLAS

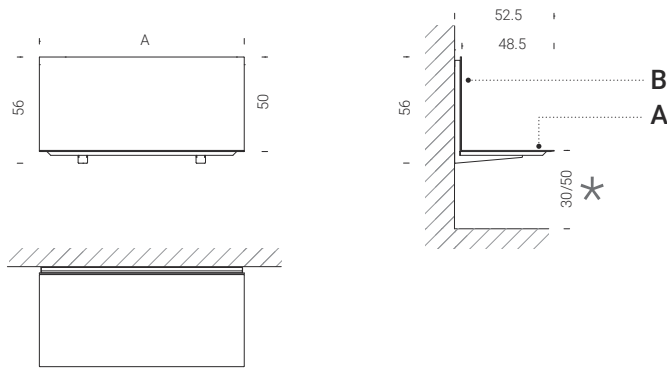

	A x 48.5	L03	L08	Q	Y
		L06	L10		
A VBSR0001 (A)	72.5 x 48.5	595	613	577	666
VBSR0002 (A)	108.5 x 48.5	722	744	700	809
VBSR0003 (A)	144.5 x 48.5	843	868	818	944

	A x 50	L03	L08	Q	Y
		L06	L10		
B VBSR0001 (B)	72.5 x 50	151	156	146	169
VBSR0002 (B)	108.5 x 50	205	211	199	230
VBSR0003 (B)	144.5 x 50	265	273	257	297

CONSOLLE CON PASSACAVO / CONSOLE WITH CABLE SLEEVE / CONSOLE AVEC PASSAGE DE CABLES KONSOLE MIT KABELDURCHGANG / CONSOLAS CON PASACABLES

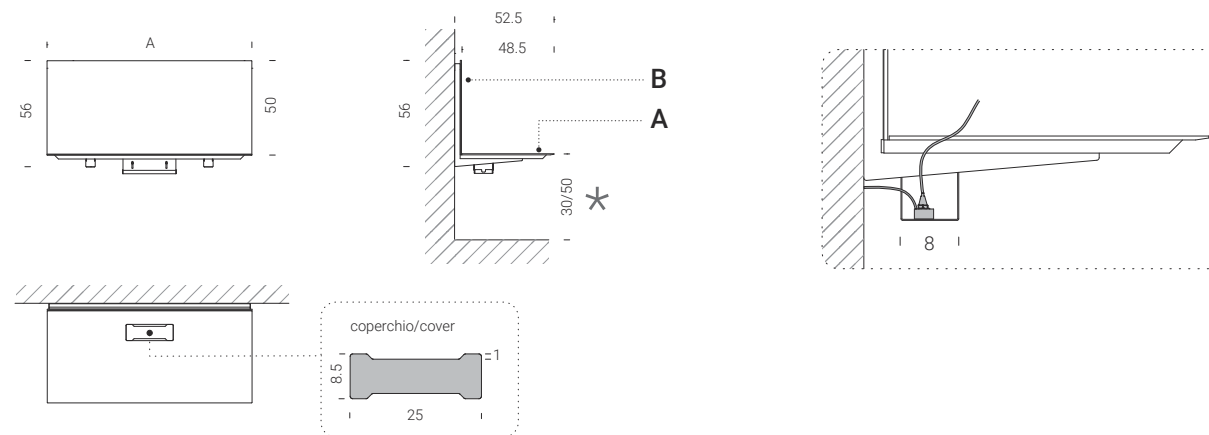

	A x 48.5	L03	L08	Q	Y
		L06	L10		
A VBSR0005 (A)	108.5 x 48.5	817	842	792	915
VBSR0006 (A)	144.5 x 48.5	938	966	910	1051

	A x 50	L03	L08	Q	Y
		L06	L10		
B VBSR0005 (B)	108.5 x 50	205	211	199	230
VBSR0006 (B)	144.5 x 50	265	273	257	297



altezza consigliata
recommended height
hauteur recommandée
Empfohlene Höhe
altura aconsejada

C acciaio verniciato/painted steel
acier peint/lackierter Stahl
acero pintado
C12 bianco/white
C08 nero/black

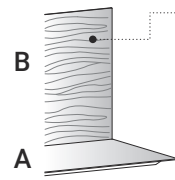

L HPL
HPL POLARIS®
L03 bianco/white
L10 grigio chiaro/light grey
L11 grigio scuro/dark grey
HPL FENIX®
L08 grigio Londra/London grey
L06 nero/black

Q HPL laccato/lacquered HPL/HPL laqué
lackiert HPL/HPL lacado
Q05 bianco/white
Q16 seta/silk
Q17 corda/ecru
Q20 ghisa/cast-iron
Q14 antracite/anthracite
Q04 nero/black
Q21 bronzo/bronze

Y HPL+ legno/HPL+wood/HPL+bois
HPL+Holz/HPL+madera
Y36 rovere/oak
Y34 noce/walnut
Y37 rovere affumicato/smoked oak
Y39 rovere nero/black oak
Y40 frassino argilla/clay ash

**CONSOLE CON PORTA-TV / CONSOLE WITH TV STAND / CONSOLE AVEC SUPPORT TV
KONSOLE MIT TV-HALTERUNG / CONSOLAS CON SOPORTE PARA TV**

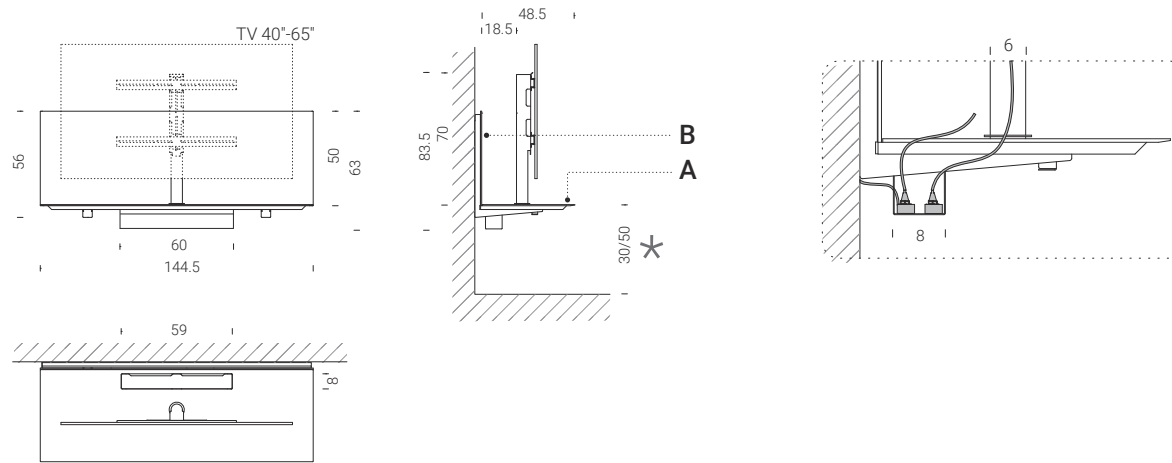

A		A x 48.5	L03	L08	Q	Y
			L06	L10		
	VBSR0007 (A)	108.5 x 48.5	1267	1305	1229	1419
	VBSR0008 (A)	144.5 x 48.5	1388	1430	1346	1555

B		A x 50	L03	L08	Q	Y
			L06	L10		
	VBSR0007 (B)	108.5 x 50	205	211	199	230
	VBSR0008 (B)	144.5 x 50	265	273	257	297

**ACCESSORI PER CONSOLE CON PORTA-TV / ACCESSORIES FOR CONSOLE WITH TV STAND / ACCESSOIRES POUR CONSOLE AVEC SUPPORT TV
ZUBEHÖR FÜR KONSOLEN MIT TV-HALTERUNG / ACCESORIOS PARA CONSOLAS CON SOPORTE PATA TV**

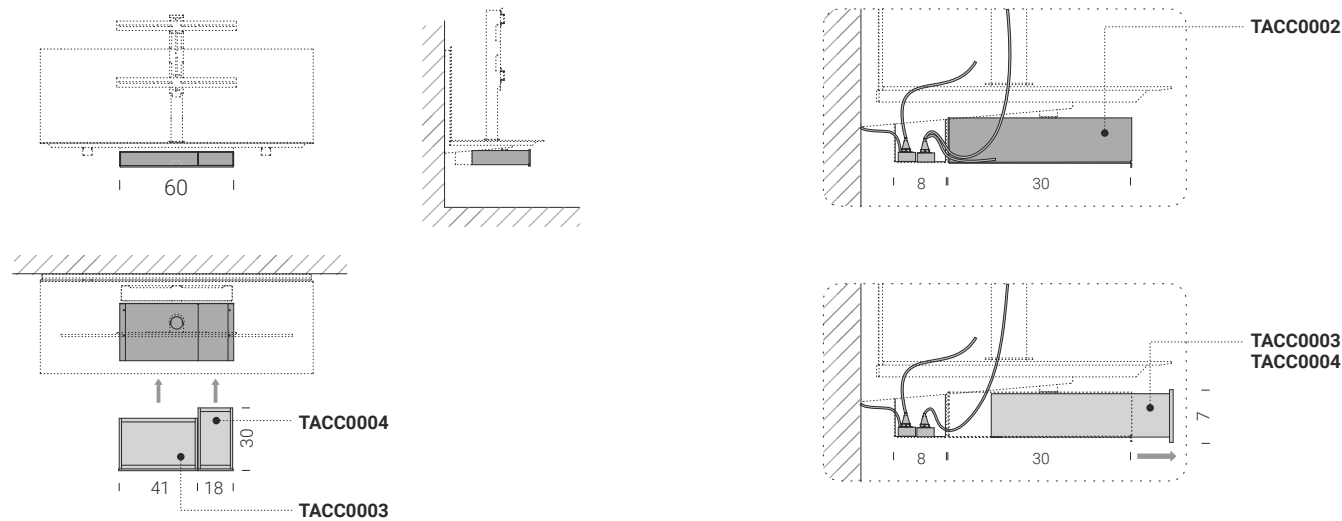

A x B x C		
TACC0002	60 x 30 x 7	206

scocca in acciaio
steel body
coque en acier
Stahlaufbau
chapa de acero

A x B x C		
TACC0003	41 x 26 x 7	129
TACC0004	18 x 30 x 7	85

frontale nella finitura della consolle
front in console finishings
façade dans la même finition que la consolle
Vorderseite in der Konsolenausführung
frontal en el acabado de la consola



altezza consigliata
recommended height
hauteur recommandée
Empfohlene Höhe
altura aconsejada



i cavi della TV e di eventuali unità multimediali sono completamente nascosti
the TV and multimedia unit wires are completely hidden
les fils de la TV et des unités multimédias sont complètement dissimulés
die Kabel des Fernsehers und der Multimedia sind vollkommen unsichtbar
los cables de la TV y de los sistemas multimedia quedan completamente ocultos



supporto monitor universale per TV da 40 a 65 pollici.
universal monitor support for TV from 40 to 65 inches.
support moniteur universel pour TV de 40 à 65 pouces.
Universal-Monitor-Halter für TV von 40 bis 65 Zoll.
soporte de monitor universal para TV de 40 a 65 pulgadas.

C acciaio verniciato/painted steel
acier peint/lackierter Stahl
acero pintado
C12 bianco/white
C08 nero/black

L HPL
HPL POLARIS®
L03 bianco/white
L10 grigio chiaro/light grey
L11 grigio scuro/dark grey
HPL FENIX®
L08 grigio Londra/London grey
L06 nero/black

Q HPL laccato/lacquered HPL/HPL laqué
lackiert HPL/HPL lacado
Q05 bianco/white
Q16 seta/silk
Q17 corda/ecru
Q20 ghisa/cast-iron
Q14 antracite/anthracite
Q04 nero/black
Q21 bronzo/bronze

Y HPL+legno/HPL+wood/HPL+bois
HPL+Holz/HPL+madera
Y36 rovere/oak
Y34 noce/walnut
Y37 rovere affumicato/smoked oak
Y39 rovere nero/black oak
Y40 frassino argilla/clay ash

SCRITTOI A PARETE / WALL-MOUNTED DESKS / BUREAUX AU MUR WANDSCHREIBTISCHE / ESCRITORIOS DE PARED

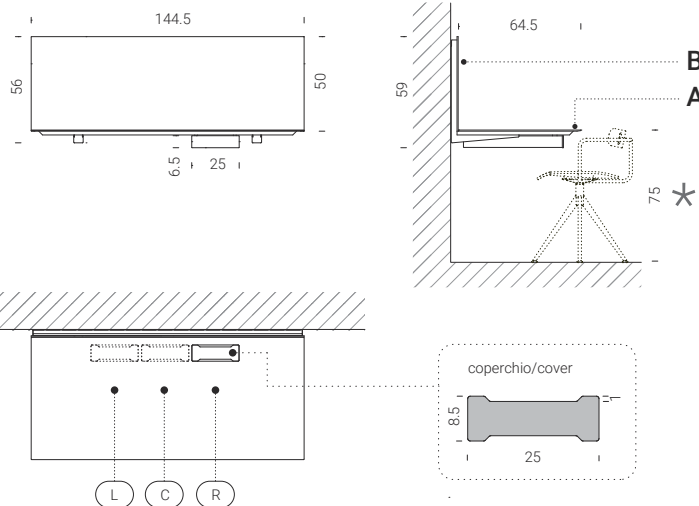

A		A x 64.5		L08	Q	Y
		L03	L10	L11		
C L/R	VBSR0009 (A)	108.5 x 64.5	982	1011	953	1100
	VBSR0010 (A)	144.5 x 64.5	1103	1136	1070	1235

non disponibili nelle finiture laccate **Q05/Q04**
not available with lacquered finishes **Q05/Q04**
non disponible en finitions laquées **Q05/Q04**
Für Lackvollendungen nicht verfügbar **Q05/Q04**
no disponible en acabados lacados **Q05/Q04**

B		A x 50		L08	Q	Y
		L03	L10	L11		
C L/R	VBSR0009 (B)	108.5 x 50	205	211	199	230
	VBSR0010 (B)	144.5 x 50	265	273	257	297

BARRE LED / LED LIGHT BARS / BARRES LED / LED-LEISTEN / BARRAS LED

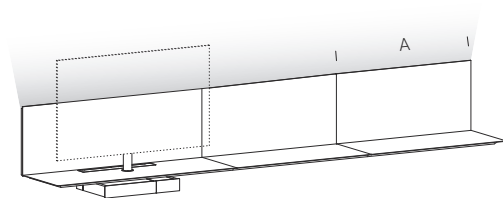

barre LED per illuminare la parete verso l'alto, posizionabili sul retro dei pannelli schiena.
LED light bars to illuminate the wall towards the ceiling, positionable on the back of back panels.
barres LED pour éclairer le mur vers le haut, à positionner à l'arrière des panneaux de dossier.
LED-Leisten zur Wandbeleuchtung oben, an der Rückseitenplatten positionierbar.
barras LED para iluminar la pared hacia arriba, que se pueden colocar en la parte posterior de trasera de los paneles.

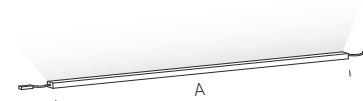

	A	WATT	
VACC0092	36	4	68
VACC0093	72.5	7	80
VACC0094	108.5	11	92
VACC0095	144.5	14	98

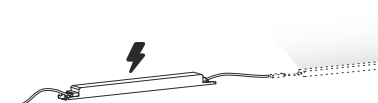

	WATT	
VACC0096	60	240
VACC0097	100	285

L/R

ordinabile in posizione L (sinistra), R (destra).
available in the following positions: L (left), R (right).
peut être commandé en position L (gauche), R (droite).
aufstellbar in Position L (links), R (rechts).
disponible en posición L (izquierda), R (derecha).

C

ordinabile in posizione C (centrale).
available in the following positions: C (central).
peut être commandé en position C (centrale).
aufstellbar in Position C (Mitte).
disponible en posición C (central).

*

altezza consigliata
recommended height
hauteur recommandée
Empfohlene Höhe
altura aconsejada

Q laccato/lacquered/laqué
lackiert/lacado

Y essenza/wood/bois
Holz/madera

X laccato metallo/metal lacquered
laqué metal/Metalllackierung
lacado metal

Q05 bianco/white

Q16 seta/silk

Q17 corda/ecru

Q20 ghisa/cast-iron

Q14 antracite/anthracite

Q04 nero/black

Q21 bronzo/bronze

Y36 rovere/oak

Y34 noce/walnut

Y37 rovere affumicato/smoked oak

Y38 rovere nero/black oak

Y40 frassino argilla/clay ash

X01 rame/copper

X02 ottone/brass

X03 titanio/titanium

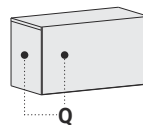

Q

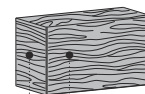

Y37
Y38

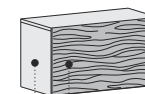

Q - Y

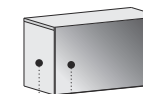

Q - X

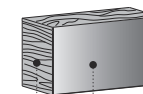

Y37 - X
Y38 - X

ANTA RIBALTA / FLAP DOOR / PORTE A ABATTANT / Klapptür / Puerta abatible

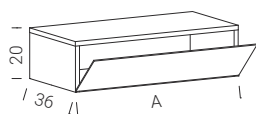

VCAR0001
VCAR0002

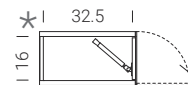

VCAR0008
VCAR0009

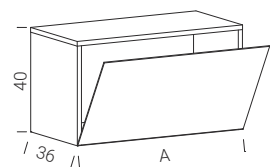
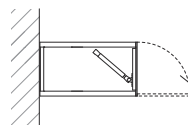

VCAR0005
VCAR0006
VCAR0007

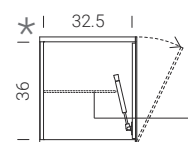

VCAR0012
VCAR0013
VCAR0014

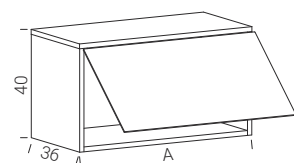
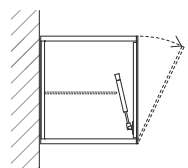

VCAR0020
VCAR0021
VCAR0022

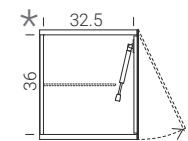

VCAR0023
VCAR0024
VCAR0025

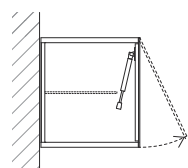

	A x 20	kg max	Q	Y37 Y38	Q-Y	Q-X	Y37-X Y38-X
VCAR0001	72.5 x 20	25	520	756	599	554	711
VCAR0002	108.5 x 20	30	625	907	719	665	853
VCAR0008	72.5 x 20	25	613	891	706	653	838
VCAR0009	108.5 x 20	30	722	1049	831	769	987

	A x 40	kg max	Q	Y37 Y38	Q-Y	Q-X	Y37-X Y38-X
VCAR0005	36 x 40	20	434	631	500	463	594
VCAR0006	72.5 x 40	25	615	894	708	655	841
VCAR0007	108.5 x 40	30	737	1071	849	785	1007
VCAR0012	36 x 40	20	517	751	595	551	707
VCAR0013	72.5 x 40	25	694	1008	799	739	948
VCAR0014	108.5 x 40	30	833	1210	959	887	1138

	A x 40	kg max	Q	Y37 Y38	Q-Y	Q-X	Y37-X Y38-X
VCAR0020	36 x 40	20	434	631	500	463	594
VCAR0021	72.5 x 40	25	615	894	708	655	841
VCAR0022	108.5 x 40	30	737	1071	849	785	1007
VCAR0023	36 x 40	20	517	751	595	551	707
VCAR0024	72.5 x 40	25	694	1008	799	739	948
VCAR0025	108.5 x 40	30	833	1210	959	887	1138



dimensioni interne
internal dimensions
dimensions internes
Innenmaße
dimensiones internas



ripiani interni non inclusi
internal shelves not included
étagères internes non incluses
Interne Einlegeböden nicht enthalten
estantes internos no incluidos



Dettaglio anta
Detail of a door
Détail de la porte
Türdetail
Detalle de la puerta

Q laccato/lacquered/laqué
lackiert/lacado

Y essenza/wood/bois
Holz/madera

X laccato metallo/metal lacquered
laqué metal/Metalllackierung
lacado metal

Q05 bianco/white
Q16 seta/silk
Q17 corda/ecru
Q20 ghisa/cast-iron
Q14 antracite/anthracite
Q04 nero/black
Q21 bronzo/bronze

Y36 rovere/oak
Y34 noce/walnut
Y37 rovere affumicato/smoked oak
Y38 rovere nero/black oak
Y40 frassino argilla/clay ash

X01 rame/copper
X02 ottone/brass
X03 titanio/titanium

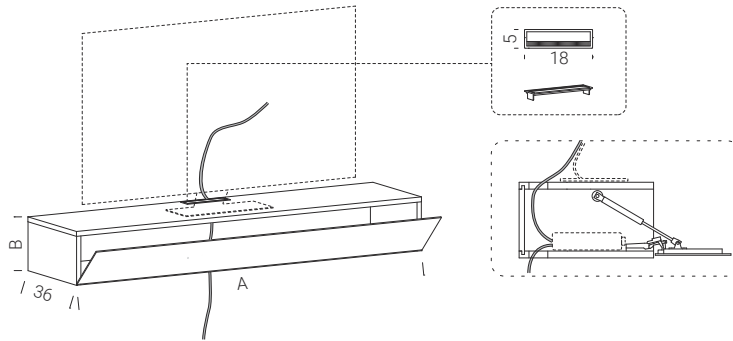
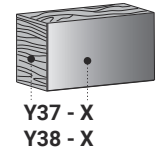
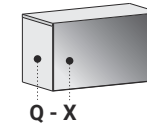
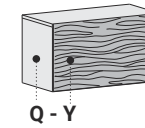
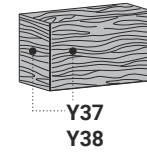
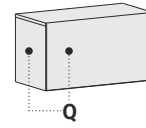

il contenitore prevede il passaggio cavi come da schema
the container incorporates the cable sleeve as shown in the diagram
le conteneur prévoit le passage des câbles comme indiqué sur le schéma
Der Turm sieht den Kabeldurchgang laut Schema vor
el contenedor prevé el paso de cables según el esquema

VCAR0015
VCAR0003

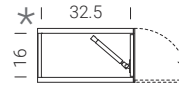

VCAR0016
VCAR0010

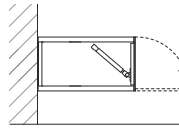

VCAR0019
VCAR0018

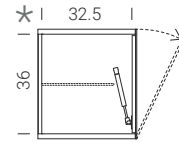

VCAR0026
VCAR0017

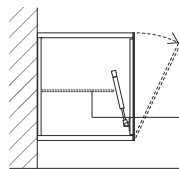

VCAR0004

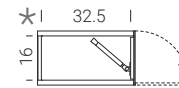

VCAR0011

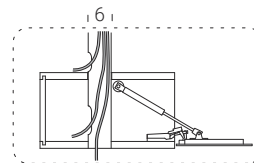
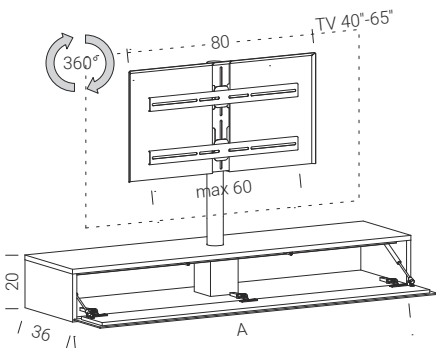
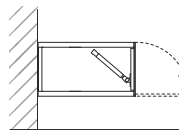

	A x 20	kg max	Q	Y37 Y38	Q-Y	Q-X	Y37-X Y38-X
VCAR0015	72.5 x 20	25	601	873	692	640	821
VCAR0003	108.5 x 20	30	685	995	789	730	936

VCAR0016	72.5 x 20	25	681	990	784	726	932
VCAR0010	108.5 x 20	30	751	1090	864	799	1025

	A x 40	kg max	Q	Y37 Y38	Q-Y	Q-X	Y37-X Y38-X
VCAR0019	72.5 x 40	25	681	990	784	726	932
VCAR0018	108.5 x 40	30	804	1167	925	856	1098

VCAR0026	72.5 x 40	25	760	1104	875	810	1039
VCAR0017	108.5 x 40	30	899	1306	1035	958	1229

	A x 20	kg max	Q	Y37 Y38	Q-Y	Q-X	Y37-X Y38-X
VCAR0004	108.5 x 20	30	958	1392	1103	1021	1310

VCAR0011	108.5 x 20	25	1044	1517	1202	1112	1427
-----------------	------------	----	------	------	------	------	------



supporto monitor universale per TV da 40 a 65 pollici.
universal monitor support for TV from 40 to 65 inches.
support moniteur universel pour TV de 40 à 65 pouces.
Universal-Monitor-Halter für TV von 40 bis 65 Zoll.
soporte de monitor universal para TV de 40 a 65 pulgadas.

*

dimensioni interne
internal dimensions
dimensions internes
Innenmaße
dimensiones internas



ripiani interni non inclusi
internal shelves not included
étagères internes non incluses
Interne Einlegeböden nicht enthalten
estantes internos no incluidos

Q laccato/lacquered/laqué
lackiert/lacado

Y essenza/wood/bois
Holz/madera

X laccato metallo/metal lacquered
laqué metal/Metalllackierung
lacado metal

Q05 bianco/white
Q16 seta/silk
Q17 corda/ecru
Q20 ghisa/cast-iron
Q14 antracite/anthracite
Q04 nero/black
Q21 bronzo/bronze

Y36 rovere/oak
Y34 noce/walnut
Y37 rovere affumicato/smoked oak
Y38 rovere nero/black oak
Y40 frassino argilla/clay ash

X01 rame/copper
X02 ottone/brass
X03 titanio/titanium

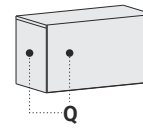

Q

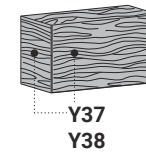

Y37
Y38

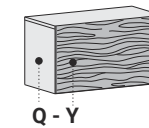

Q - Y

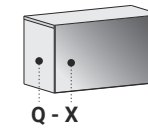

Q - X

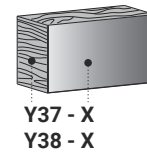

Y37 - X
Y38 - X

ANTE BATTENTE / LEAF DOOR UNITS / PORTE À BATTANT / FLÜGELTÜR / PUERTA BATIENTE

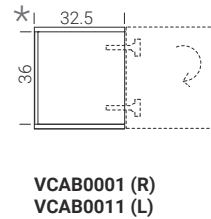
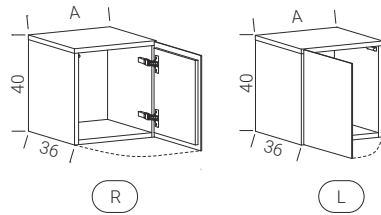

VCAB0001 (R)
VCAB0011 (L)

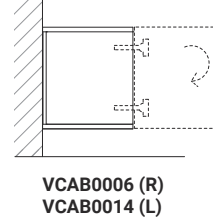

VCAB0006 (R)
VCAB0014 (L)

	A x 40	kg max	Q	Y37 Y38	Q-Y	Q-X	Y37-X Y38-X	
(R)	VCAB0001	36 x 40	25	390	636	473	430	593
(L)	VCAB0011	36 x 40	25	390	636	473	430	593

(R)	VCAB0006	36 x 40	25	476	776	577	525	724
(L)	VCAB0014	36 x 40	25	476	776	577	525	724

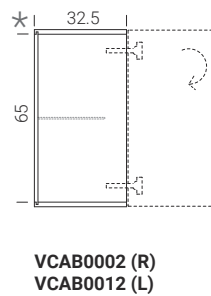
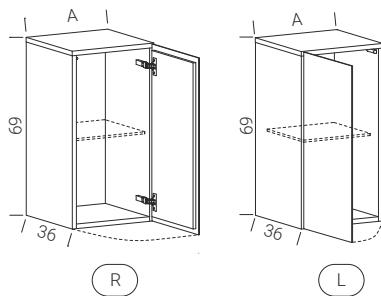

VCAB0002 (R)
VCAB0012 (L)

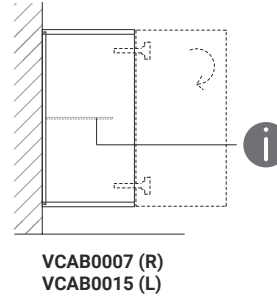

VCAB0007 (R)
VCAB0015 (L)

	A x 69	kg max	Q	Y37 Y38	Q-Y	Q-X	Y37-X Y38-X	
(R)	VCAB0002	36 x 69	25	487	793	590	537	740
(L)	VCAB0012	36 x 69	25	487	793	590	537	740

(R)	VCAB0007	36 x 69	25	572	931	693	630	868
(L)	VCAB0015	36 x 69	25	572	931	693	630	868

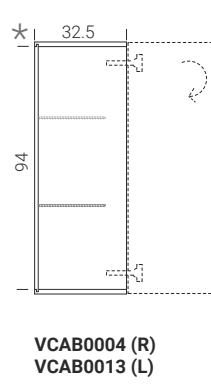
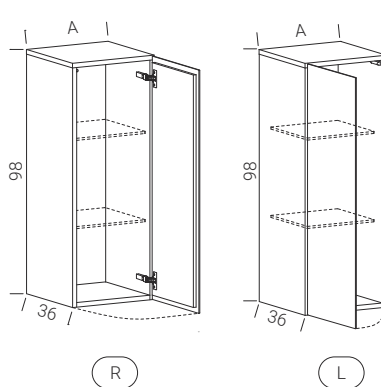

VCAB0004 (R)
VCAB0013 (L)

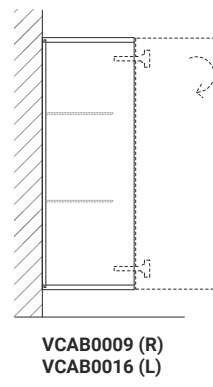

VCAB0009 (R)
VCAB0016 (L)

	A x 98	kg max	Q	Y37 Y38	Q-Y	Q-X	Y37-X Y38-X	
(R)	VCAB0004	36 x 98	25	504	821	611	556	766
(L)	VCAB0013	36 x 98	25	504	821	611	556	766

(R)	VCAB0009	36 x 98	25	667	1086	808	735	1013
(L)	VCAB0016	36 x 98	25	667	1086	808	735	1013

★
dimensioni interne
internal dimensions
dimensions internes
Innenmaße
dimensiones internas

ⓘ
ripianti interni non inclusi
internal shelves not included
étagères internes non incluses
Interne Einlegeböden nicht enthalten
estantes internos no incluidos

Q laccato/lacquered/laqué
lackiert/lacado

Y essenza/wood/bois
Holz/madera

X laccato metallo/metal lacquered
laqué metal/Metallackierung
lacado metal

- Q05 bianco/white
- Q16 seta/silk
- Q17 corda/ecru
- Q20 ghisa/cast-iron
- Q14 antracite/anthracite
- Q04 nero/black
- Q21 bronzo/bronze

- Y36 rovere/oak
- Y34 noce/walnut
- Y37 rovere affumicato/smoked oak
- Y38 rovere nero/black oak
- Y40 frassino argilla/clay ash

- X01 rame/copper
- X02 ottone/brass
- X03 titanio/titanium

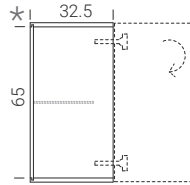
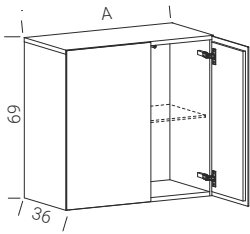
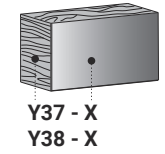
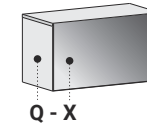
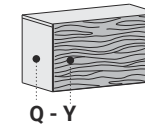
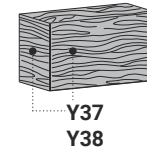
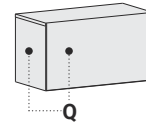

VCAB0003

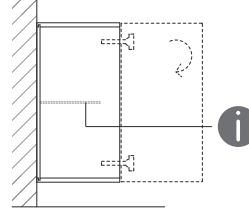

VCAB0008

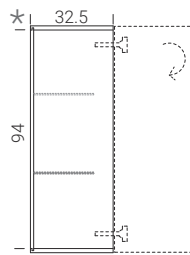
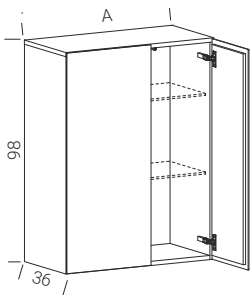

VCAB0005

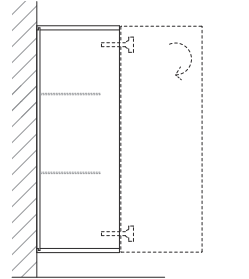

VCAB0010

	A x 69	kg max	Q	Y37 Y38	Q-Y	Q-X	Y37-X Y38-X
VCAB0003	72.5 x 69	25	763	1243	925	841	1159

VCAB0008	72.5 x 69	25	796	1296	965	877	1208
----------	-----------	----	-----	------	-----	-----	------

	A x 98	kg max	Q	Y37 Y38	Q-Y	Q-X	Y37-X Y38-X
VCAB0005	72.5 x 98	25	825	1344	1000	910	1254

VCAB0010	72.5 x 98	25	878	1430	1064	968	1334
----------	-----------	----	-----	------	------	-----	------

RIPIANI / SHELVES / ÉTAGÈRES / BÖDEN / ESTANTES

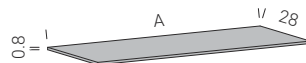
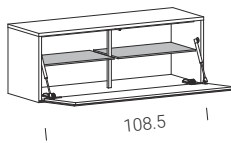
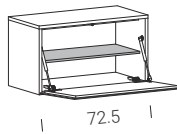
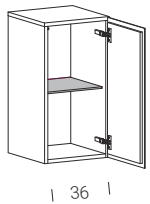

forature per supporti ripiano da eseguire in opera Ø5 mm
holes for shelf supports to be drilled Ø5 mm
trous pour supports d'étagères à réaliser sur place Ø5 mm
Löcher für Einlegebodenhalter sind mit Ø5 mm vorzunehmen
orificios para soportes de baldas a realizar in situ Ø5 mm

	A x 28	V07
ARIV0035	36 x 28	54
ARIV0036	72.5 x 28	63
ARIV0039	108.5 x 28	95

PANNELLO RETRO CONTENITORE / CONTAINER BACK PANEL / PANNEAU ARRIÈRE CONTENEUR / RÜCKSEITENPLATTEN TURM / PANEL POSTERIOR CONTENEDOR

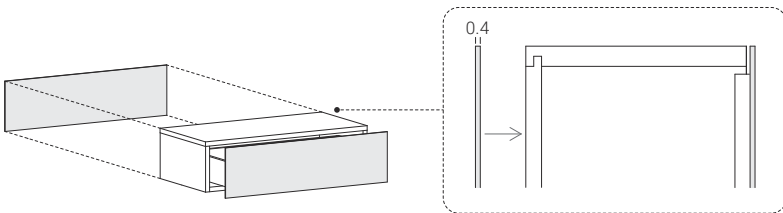

Per le composizioni bifacciali è disponibile un frontale del contenitore da utilizzare come pannello retro. **Prezzo su richiesta.**
For double-sided compositions, a container front panel is available that can be used as a back panel. **Price on request.**
Pour les compositions double face, une face avant du conteneur est disponible pour servir de panneau arrière. **Prix sur demande.**
Für die beidseitigen Kombinationen ist eine als Rückseitenplatte verwendbare Vorderseite des Turms verfügbar. **Preis auf Anfrage.**
Para las composiciones de doble cara está disponible un frontal del contenedor para usar como panel posterior. **Precio bajo petición.**



dimensioni interne
internal dimensions
dimensions internes
Innenmaße
dimensiones internas



ripiani interni non inclusi
internal shelves not included
étagères internes non incluses
Interne Einlegeböden nicht enthalten
estantes internos no incluidos



il codice prevede una coppia di ripiani
the code includes two shelves
le code prévoit deux étagères
Artikelnummer sieht ein Einlegebodenpaar vor
el código prevé un par de estantes

Q laccato/lacquered/laqué
lackiert/lacado

Y essenza/wood/bois
Holz/madera

X laccato metallo/metal lacquered
laqué metal/Metalllackierung
lacado metal

Q05 bianco/white
Q16 seta/silk
Q17 corda/ecru
Q20 ghisa/cast-iron
Q14 antracite/anthracite
Q04 nero/black
Q21 bronzo/bronze

Y36 rovere/oak
Y34 noce/walnut
Y37 rovere affumicato/smoked oak
Y38 rovere nero/black oak
Y40 frassino argilla/clay ash

X01 rame/copper
X02 ottone/brass
X03 titanio/titanium

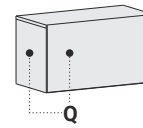

Q

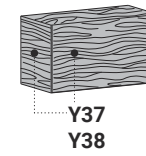

Y37
Y38

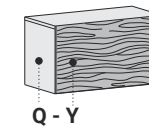

Q - Y

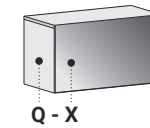

Q - X

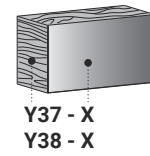

Y37 - X
Y38 - X

CASSETTIERE / DRAWERS UNITS / KITS DE TIROIRS / SCHUBLADENELEMENTE / CAJONERAS

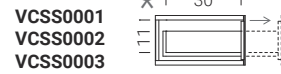
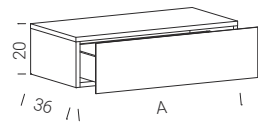

VCSS0001
VCSS0002
VCSS0003

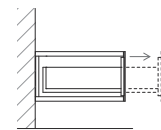

VCSS0007
VCSS0008
VCSS0009

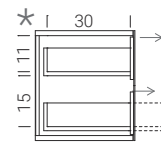
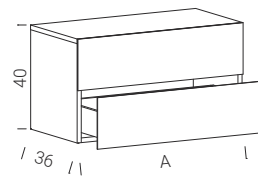

VCSS0004
VCSS0005
VCSS0006

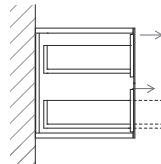

VCSS0010
VCSS0011
VCSS0012

	A x 20	kg max	Q	Y37 Y38	Q-Y	Q-X	Y37-X Y38-X
VCSS0001	36 x 20	25	353	498	398	373	473
VCSS0002	72.5 x 20	25	460	648	517	486	617
VCSS0003	108.5 x 20	25	569	803	640	602	765

VCSS0007	36 x 20	25	439	619	494	464	589
VCSS0008	72.5 x 20	25	546	769	614	576	731
VCSS0009	108.5 x 20	25	643	907	724	680	863

	A x 40	kg max	Q	Y37 Y38	Q-Y	Q-X	Y37-X Y38-X
VCSS0004	36 x 40	25	516	728	581	546	693
VCSS0005	72.5 x 40	25	670	945	754	708	899
VCSS0006	108.5 x 40	25	815	1150	917	862	1095

VCSS0010	36 x 40	25	595	839	669	629	799
VCSS0011	72.5 x 40	25	749	1057	843	792	1007
VCSS0012	108.5 x 40	25	917	1294	1032	970	1232

CONTENITORE APERTO / OPEN CABINET / COMPARTIMENT OUVERT / OFFENER BEHÄLTER / MÓDULO ABIERTO

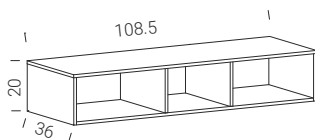
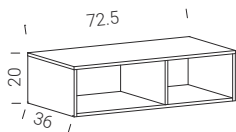

		kg max	Q	Y37 Y38
VCAP0001	72.5 x 20	30	300	484

		kg max	Q	Y37 Y38
VCAP0002	108.5 x 20	30	374	574

★
dimensioni interne
internal dimensions
dimensions internes
Innenmaße
dimensiones internas

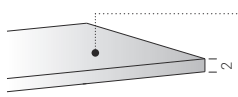

Q laccato/lacquered/laqué
lackiert/lacado

Q05 bianco/white
Q16 seta/silk
Q17 corda/ecru
Q20 ghisa/cast-iron
Q14 antracite/anthracite
Q04 nero/black
Q21 bronzo/bronze

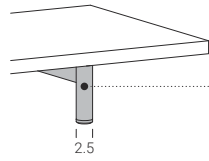

C acciaio verniciato/painted steel/acier peint
lackierter Stahl/acero pintado

C12 bianco/white
C21 seta/silk
C23 corda/ecru
C30 ghisa/cast-iron
C14 antracite/anthracite
C08 nero/black
C29 bronzo/bronze

BASE / BASE / BASE / BASIS / BASE

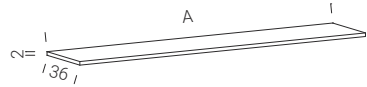

	A x 36	H	Q
VACC0026	36 x 36	2	156
VACC0027	72 x 36	2	186
VACC0028	72.5 x 36	2	186
VACC0069	108 x 36	2	232
VACC0029	108.5 x 36	2	232
VACC0030	144.5 x 36	2	280
VACC0031	145 x 36	2	280
VACC0073	180.5 x 36	2	309
VACC0032	181 x 36	2	309
VACC0033	217 x 36	2	359
VACC0034	217.5 x 36	2	359
VACC0035	253 x 36	2	411
VACC0036	253.5 x 36	2	411
VACC0066	289 x 36	2	448
VACC0037	289.5 x 36	2	448
VACC0063	290 x 36	2	448
VACC0038	325.5 x 36	2	544
VACC0076	326 x 36	2	544
VACC0039	72 x 36	11	444
VACC0040	72.5 x 36	11	444
VACC0070	108 x 36	11	484
VACC0041	108.5 x 36	11	484
VACC0042	144.5 x 36	11	531
VACC0043	145 x 36	11	531
VACC0074	180.5 x 36	11	556
VACC0044	181 x 36	11	556
VACC0045	217 x 36	11	766
VACC0046	217.5 x 36	11	766
VACC0047	253 x 36	11	831
VACC0048	253.5 x 36	11	831
VACC0067	289 x 36	11	881
VACC0049	289.5 x 36	11	881
VACC0064	290 x 36	11	881
VACC0050	325.5 x 36	11	962
VACC0077	326 x 36	11	962

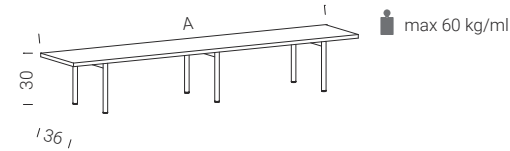
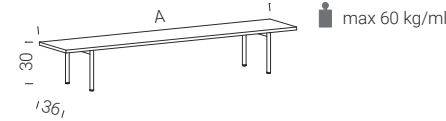
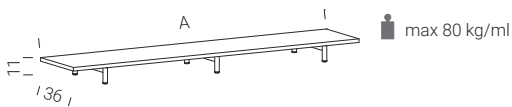
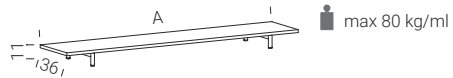

	A x 36	H	Q
VACC0051	72 x 36	30	464
VACC0052	72.5 x 36	30	464
VACC0071	108 x 36	30	515
VACC0053	108.5 x 36	30	515
VACC0054	144.5 x 36	30	563
VACC0055	145 x 36	30	563
VACC0075	180.5 x 36	30	586
VACC0056	181 x 36	30	586
VACC0057	217 x 36	30	815
VACC0058	217.5 x 36	30	815
VACC0059	253 x 36	30	853
VACC0060	253.5 x 36	30	853
VACC0068	289 x 36	30	929
VACC0061	289.5 x 36	30	929
VACC0065	290 x 36	30	929
VACC0062	325.5 x 36	30	1007
VACC0078	326 x 36	30	1007

**BASI PER MODULI IN ACCIAIO OUTDOOR / BASES FOR OUTDOOR STEEL MODULES
BASES POUR MODULES EN ACIER POUR EXTÉRIEUR / SOCKEL FÜR OUTDOOR-STAHLMODULE
BASES PARA MÓDULOS DE ACERO PARA EXTERIORES**

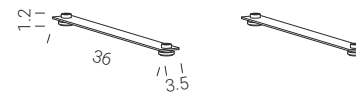

	H	C	
VACC0024	3.5 x 35	1.2	123

set di due/set of two/lot de deux
2er-Set/set de dos

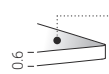

- L HPL POLARIS®**
L03 bianco/white
L10 grigio chiaro/light grey
L11 grigio scuro/dark grey
- HPL FENIX®**
L08 grigio Londra/London grey
L06 nero/black

- Q HPL laccato/lacquered HPL/HPL laqué
lackiert HPL/HPL lacado**
Q16 seta/silk
Q17 corda/ecru
Q20 ghisa/cast-iron
Q14 antracite/anthracite
Q21 bronzo/bronze

- S ceramica/ceramic/c eramique
Keramik/cer mico**
S05 antracite/anthracite
S06 nero/black
S07 porfido/porfido
S08 cardoso/cardoso

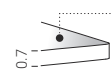

- Y HPL+ legno/wood/bois/Holz/madera**
Y36 rovere/oak
Y34 noce/walnut
Y37 rovere affumicato/smoked oak
Y38 rovere nero/black oak
Y40 frassino argilla/clay ash

TOP / TOP / PLATEAU / PLATTE / PLANO

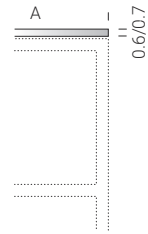

	A x 36	L03 L06	L08 L10 L11	Q	* S	Y
VRIP0046	36 x 36	81	90	70	95	97
VRIP0047	72 x 36	141	156	123	166	168
VRIP0048	72.5 x 36	141	156	123	166	168
VRIP0094	108 x 36	189	210	165	223	226
VRIP0049	108.5 x 36	189	210	165	223	226
VRIP0050	144.5 x 36	238	264	207	281	284
VRIP0051	145 x 36	238	264	207	281	284
VRIP0092	180.5 x 36	277	307	241	327	331
VRIP0052	181 x 36	277	307	241	327	331
VRIP0053	217 x 36	343	382	299	405	410
VRIP0054	217.5 x 36	343	382	299	405	410
VRIP0055	253 x 36	398	442	346	470	475
VRIP0056	253.5 x 36	398	442	346	470	475
VRIP0093	289 x 36	446	496	388	527	533
VRIP0057	289.5 x 36	446	496	388	527	533
VRIP0085	290 x 36	446	496	388	527	533
VRIP0058	325.5 x 36	498	553	433	-	595
VRIP0091	326 x 36	498	553	433	-	595

LAVORAZIONE SU TOP PER PASSAGGIO CAVI / MACHINING ON THE TOP FOR CABLE ROUTING TRAITEMENT DU PLATEAU POUR LE PASSAGE DES C BLES BEARBEITUNG DES TOP F R DIE KABELDURCHF HRUNG ELABORACI N EN LA ENCIMERA PARA EL ENRUTAMIENTO DE CABLES

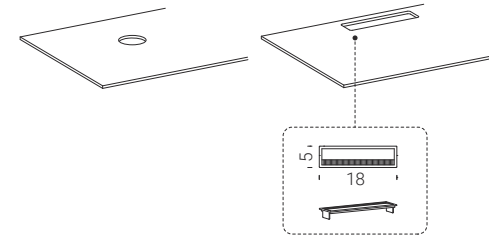

VACC0079	80
----------	----

KIT PER APPOGGIO MARMO / MARBLE TOP SUPPORT KIT KIT DE SUPPORT POUR PLATEAU EN MARBRE BEFESTIGUNGSSET F R DIE MARMORPLATTE (TOP) KIT DE SOPORTE PARA ENCIMERA DE M RMOL

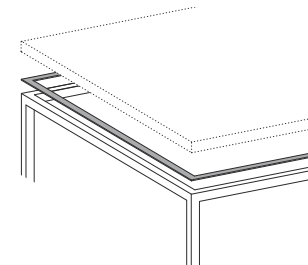

	A x 36	
VACC0072	36 x 36	8
VACC0072	72 x 36	12
VACC0072	72.5 x 36	12
VACC0072	108 x 36	20
VACC0072	108.5 x 36	20
VACC0072	144.5 x 36	26
VACC0072	145 x 36	26
VACC0072	180.5 x 36	32
VACC0072	181 x 36	32
VACC0072	217 x 36	38
VACC0072	217.5 x 36	38
VACC0072	253 x 36	45
VACC0072	253.5 x 36	45
VACC0072	289 x 36	52
VACC0072	289.5 x 36	52
VACC0072	290 x 36	52
VACC0072	325.5 x 36	58
VACC0072	326 x 36	58



Il top in ceramica non   disponibile per composizioni sospese a parete.
 The ceramic top is not available for wall-suspended compositions.
 Le plateau en c eramique n'est pas disponible pour les compositions suspendues.
 Die Keramikabdeckplatte ist f r an der Wand h ngende Kombinationen nicht verf gbar.
 La encimera de cer mica no est  disponible para composiciones suspendidas en la pared.

Il kit   composto da un materassino in neoprene adesivo che pu  essere tagliato e applicato in opera.
 The kit consists of an adhesive neoprene mat that can be cut and applied on site.
 Le kit se compose d'un petit matelas en n oprene adh sif qui peut  tre d coup  et appliqu  sur place.
 Das Set beinhaltet eine selbstklebende Neoprenmatte, die bei Bedarf zugeschnitten und aufgeklebt werden kann.
 El kit consiste en una estera adhesiva de neopreno que se puede cortar y aplicar en el sitio.



- C12** bianco/white
C21 seta/silk
C23 corda/ecru
C30 ghisa/cast-iron
C14 antracite/anthracite
C08 nero/black
C29 bronzo/bronze

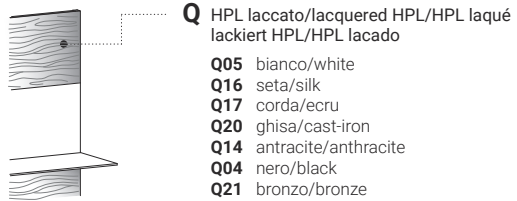

- Q05** bianco/white
Q16 seta/silk
Q17 corda/ecru
Q20 ghisa/cast-iron
Q14 antracite/anthracite
Q04 nero/black
Q21 bronzo/bronze

Y HPL+ legno/wood/bois
Holz/madera

- Y36** rovere/oak
Y34 noce/walnut
Y37 rovere affumicato/smoked oak
Y38 rovere nero/black oak
Y40 frassino argilla/clay ash

RIPIANI A PARETE / WALL SHELVES / TABLETTES MURALS / WANDREGALE / ESTANTES A PARED

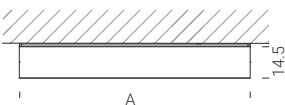
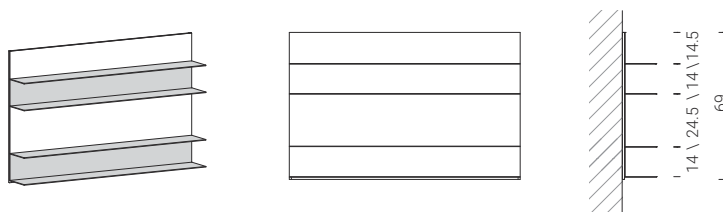
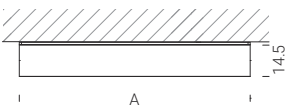
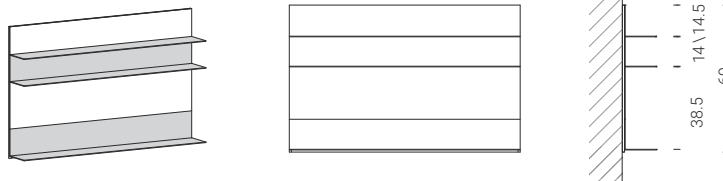
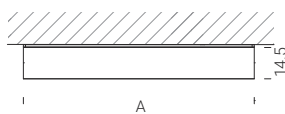
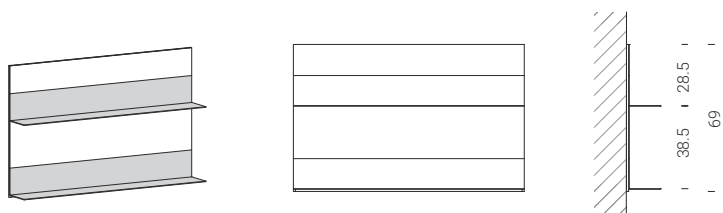

	A x 69	Q	Y
VBSR0011	72.5 x 69	595	678
VBSR0012	108.5 x 69	700	825

	A x 69	Q	Y
VBSR0013	72.5 x 69	639	721
VBSR0014	108.5 x 69	765	890

	A x 69	Q	Y
VBSR0015	72.5 x 69	682	765
VBSR0016	108.5 x 69	830	954



non riducibili
 non-reducible items
 aucune réduction possible
 nicht verkürzbar
 no reducibles

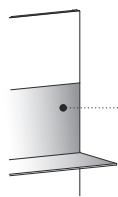

C alluminio verniciato/painted aluminium/aluminium peint
lackierter Aluminium/aluminio pintado

- C12** bianco/white
- C21** seta/silk
- C23** corda/ecru
- C30** ghisa/cast-iron
- C14** antracite/anthracite
- C08** nero/black
- C29** bronzo/bronze



Q HPL laccato/lacquered HPL/HPL laqué
lackiert HPL/HPL lacado

- Q05** bianco/white
- Q16** seta/silk
- Q17** corda/ecru
- Q20** ghisa/cast-iron
- Q14** antracite/anthracite
- Q04** nero/black
- Q21** bronzo/bronze

Y HPL+ legno/wood/bois
Holz/madera

- Y36** rovere/oak
- Y34** noce/walnut
- Y37** rovere affumicato/smoked oak
- Y38** rovere nero/black oak
- Y40** frassino argilla/clay ash

RIPIANI A PARETE / WALL SHELVES / TABLETTES MURALS / WANDREGALE / ESTANTES A PARED

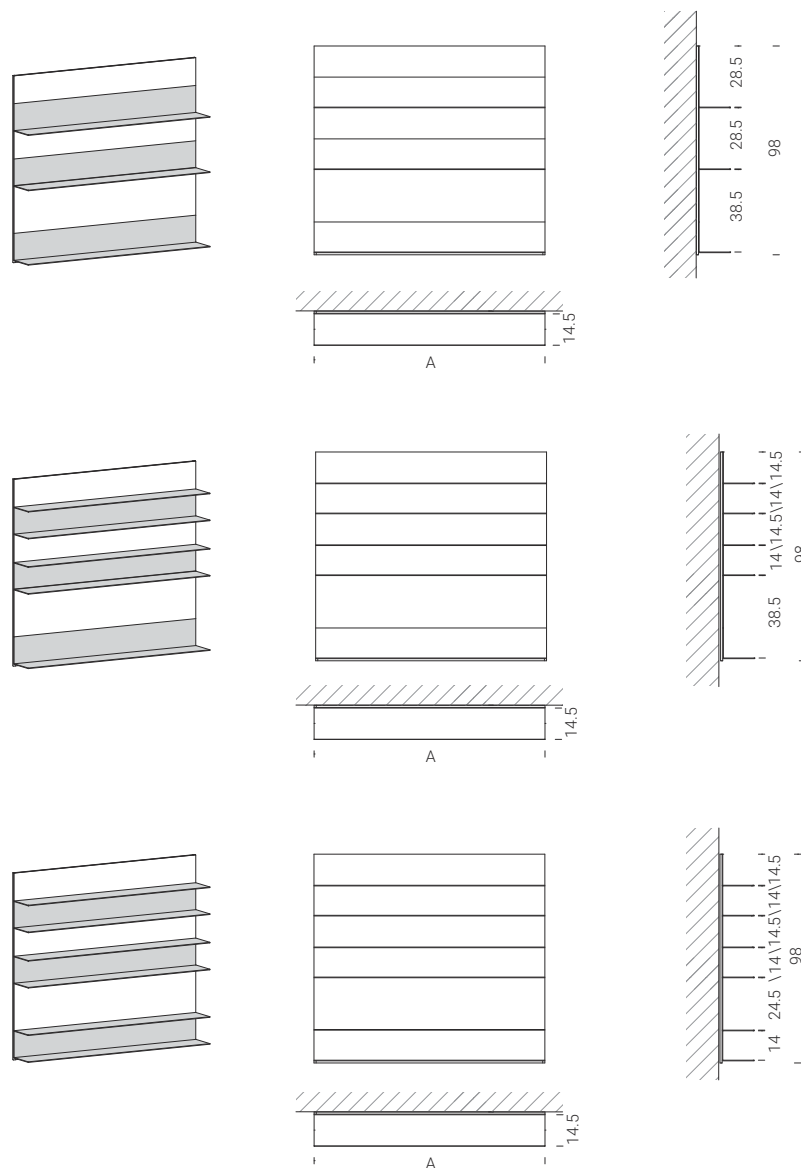

	A x 98	Q	Y
VBSR0017	72.5 x 98	717	756
VBSR0018	108.5 x 98	871	930

	A x 98	Q	Y
VBSR0019	72.5 x 98	804	843
VBSR0020	108.5 x 98	1001	1060

	A x 98	Q	Y
VBSR0021	72.5 x 98	847	887
VBSR0022	108.5 x 98	1066	1125



non riducibili
non-reducible items
aucune réduction possible
nicht verkürzbar
no reducibles

MONOLITH



LA SCOCCA IN ALLUMINIO ESTRUSO CHE COSTITUISCE L'OSSATURA PORTANTE DI MONOLITH, CONSENTE GRANDE RIGIDITÀ STRUTTURALE E UNA LIBERA CONFIGURAZIONE DELLE PARTIZIONI INTERNE. TALE SISTEMA COSTRUTTIVO FORMA UN INSIEME MOLTO SEMPLICE DA ASSEMBLARE E RICONFIGURARE, EVITANDO DI RADDOPPIARE GLI SPESSORI DEI FIANCHI AL SUO INTERNO.

The frame in extruded aluminium forming the support structure of Monolith gives an extremely firm structure with free configuration of the inner partitions. This composition system forms a very simple set to assemble and re-configure, without doubling the thicknesses of its inner sides

Le châssis en aluminium extrudé qui constitue l'ossature portante de monolith, permet une grande rigidité structurelle et une libre configuration des divisions internes. Ce système de construction forme un ensemble très simple à assembler et reconfigurer, en évitant de doubler les épaisseurs des côtés à l'intérieur

Der Aufbau aus extrudiertem Aluminium, der das tragenden Gerüst des monolith darstellt, bietet eine bedeutende, strukturelle Steifheit und eine freie Konfigurierung der Innenaufteilung. Dieses Konstruktionssystem bildet eine Einheit, die einfach zusammenzubauen und neu zu gestalten ist, wobei die Verdoppelung der Stärke der Seiten im Innenbereich vermieden wird.

El bastidor de aluminio extruido que constituye el armazón de soporte de Monolith permite una gran resistencia estructural y una libre configuración de las particiones interiores. Este sistema de construcción forma un conjunto muy fácil de montar y reconfigurar, evitando duplicar el espesor de los laterales en su interior.





PRODUCT CONCEPT

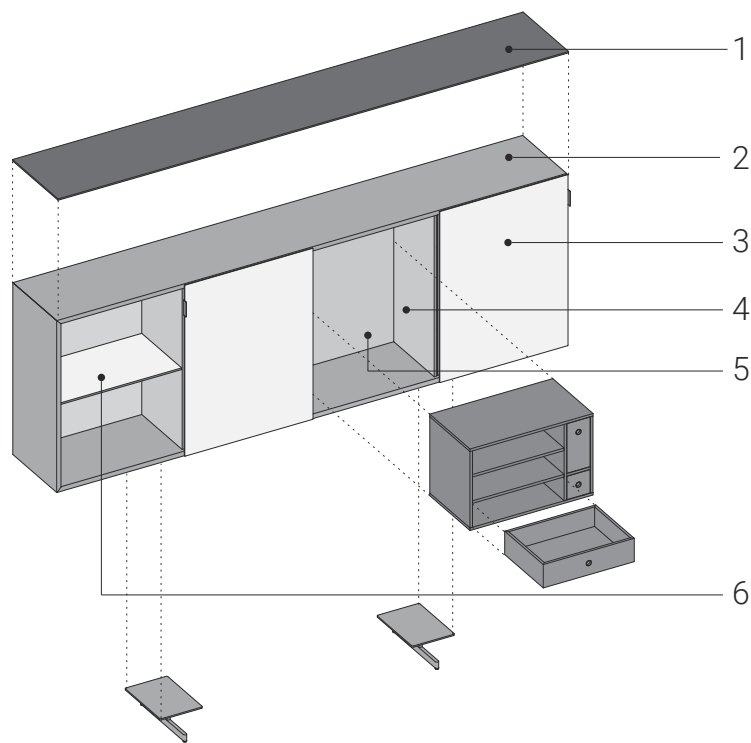

L modules
121.6 – 181 – 240.4

H modules
42.6 – 81 – 119.4 - 162

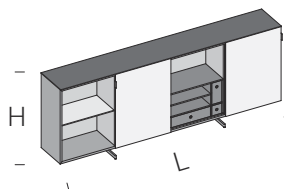

È possibile la sovrapposizione ed affiancamento dei moduli.

The modules can be overlapped or side-by-side.

Les modules peuvent être superposés et placés les uns à côté des autres.

Die Module können nebeneinander und übereinander montiert werden.

Son posibles los módulos superpuestos y adosados.



Pavimento / parete
Floor / wall
Sol / mur
Boden / Wand
Suelo / pared

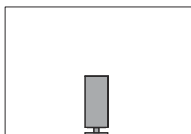

Centro stanza
Room divider units
Centre de la pièce
Zimmermitte
Centro de la habitación



Passacavi disponibili su pannello schiena e contenitori interni.

Cable sleeves available on the back panel and internal containers
Passe-câbles disponibles sur le panneau arrière et pour les conteneurs internes.

Kabeldurchgänge auf Rückenplatte und inneren Behältern möglich.

Pasacables disponibles en el panel trasero y en los contenedores internos.



Caratteristiche costruttive
Construction characteristics
Caractéristiques de construction
Konstruktionsmerkmale
Características constructivas

1

TOP / TOP / PLATEAU / PLATTE / PLANO

POLARIS® / FENIX®

L03 bianco/white
L10 grigio chiaro/light grey
L11 grigio scuro/dark grey
L08 grigio Londra/London grey
L06 nero/black

HPL+ metallo/metal/métal
Metall/metal

C31 ottone/brass
C32 ottone brunito/burnished brass
C35 inox / inox
C36 inox scuro/dark inox

HPL+ ecotouch

N01 sabbia/sand
N02 basalto/basalt

HPL+ legno/wood/bois
Holz/madera

Y36 rovere/oak
Y34 noce/walnut
Y37 rovere affumicato/smoked oak
Y40 frassino argilla/clay ash
Y39 frassino nero/black ash

ceramica/ceramic/céramique
Keramik/cerámico

S05 antracite/anthracite
S06 nero/black
S07 porfido/porfido
S08 cardoso/cardoso

HPL laccato/lacquered HPL/HPL laqué
lackiertem HPL/HPL lacado

Q16 seta/silk
Q17 corda/ecru
Q20 ghisa/cast-iron
Q14 antracite/anthracite
Q21 bronzo/bronze

HPL+ cemento/concrete/ciment
zement/cemento

D01 bianco calce/lime white
D02 grigio Portland/Portland grey
D03 nero/black

2

SCOCHE / SHELLS / CADRES / GEHÄUSE / ESTRUCTURAS

alluminio verniciato/painted aluminium/aluminium paint
lackierter Aluminium/aluminio pintado

C12 bianco/white
C21 seta/silk
C23 corda/ecru
C30 ghisa/cast-iron

C14 antracite/anthracite
C08 nero/black
C29 bronzo/bronze

3

FRONTALI / DOORS FRONTS / FACES DES PORTES / FRONTEN DER TÜREN / PUERTAS

vetro laccato/lacquered glass
verre laqué/Glas lackiert
cristal lacado

Q05 bianco/white
Q16 seta/silk
Q17 corda/ecru
Q20 ghisa/cast-iron

Q14 antracite/anthracite
Q04 nero/black
Q21 bronzo/bronze

vetro laccato metallo/metal lacquered glass
verre laqué metal/ Glas metallackierung
cristal lacado metal

X01 rame/copper
X02 ottone/brass
X03 titanio/titanium

4

FIANCHI/ SIDES / CÔTÉS / SEITENWÄNDE / LATERALES

MDF laccato/lacquered MDF/MDF laqué
lackiertem MDF/DM lacado

Q05 bianco/white
Q16 seta/silk
Q17 corda/ecru
Q20 ghisa/cast-iron

Q14 antracite/anthracite
Q04 nero/black
Q21 bronzo/bronze

5

SCHIENE / BACKS / DOS / RÜCKWÄNDE / TRASERAS

MDF laccato/lacquered MDF/MDF laqué
lackiertem MDF/DM lacado

Q05 bianco/white
Q16 seta/silk
Q17 corda/ecru
Q20 ghisa/cast-iron

Q14 antracite/anthracite
Q04 nero/black
Q21 bronzo/bronze

MDF legno/wood MDF/MDF bois
Holz MDF/DM madera

Y36 rovere/oak
Y34 noce/walnut

6

RIPIANI / SHELVES / ÉTAGÈRES / BÖDEN / ESTANTES

vetro laccato/lacquered glass/verre laqué
Glas lackiert/cristal lacado

Q05 bianco/white
Q16 seta/silk
Q17 corda/ecru
Q20 ghisa/cast-iron

Q14 antracite/anthracite
Q04 nero/black
Q21 bronzo/bronze

vetro trasparente/transparentglass/verre transparent
Glas transparent/cristal transparente

V07 float
V06 fumè/smoked glass

Q laccato/lacquered/laqué
lackiert/lacado

Y essenza/wood/bois
Holz/madera

X laccato metallo/metal lacquered
laqué metal/Metalllackierung
lacado metal



QQ



YQ



QX



YX

supporti disponibili
supports available



p. 65

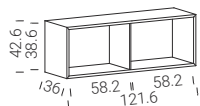

	QQ	YQ	QX	YX
MCOM0006	1305	1366	-	-



p. 65

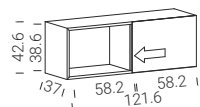

	QQ	YQ	QX	YX
MCOM0021	1582	1643	1654	1715



p. 65

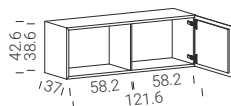

	QQ	YQ	QX	YX
MCOM0048	1587	1648	1647	1708



p. 65

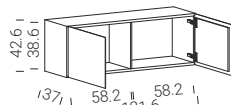

	QQ	YQ	QX	YX
MCOM0039	1850	1911	1970	2031



p. 65

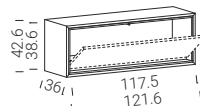

	QQ	YQ	QX	YX
MCOM0015	1223	1284	-	-



scrivitoio non incluso nel prezzo, info pagina 62
writing desk not included in the price, info on page 62
secrétaire non inclus dans le prix, info page 62
Schreibtisch, nicht im Preis inbegriffen, Info Seite 62
escritorio no incluido en el precio, página de información 62

Q laccato/lacquered/laqué
lackiert/lacado

Y essenza/wood/bois
Holz/madera

X laccato metallo/metal lacquered
laqué metal/Metalllackierung
lacado metal



QQ



YQ



QX



YX

supporti disponibili
supports available



p. 65

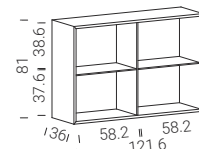

	QQ	YQ	QX	YX
MCOM0007	1593	1714	-	-



p. 65

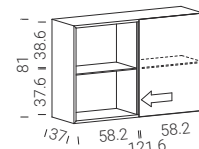

	QQ	YQ	QX	YX
MCOM0022	1982	2103	2083	2204



p. 65

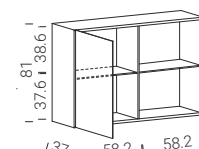

	QQ	YQ	QX	YX
MCOM0049	2184	2305	2273	2394



p. 65

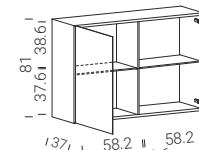

	QQ	YQ	QX	YX
MCOM0040	2575	2696	2753	2874

Q laccato/lacquered/laqué
lackiert/lacado

Y essenza/wood/bois
Holz/madera

X laccato metallo/metal lacquered
laqué metal/Metalllackierung
lacado metal

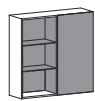

QQ

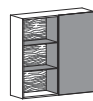

YQ

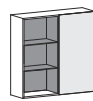

QX

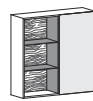

YX

Q laccato/lacquered/laqué
lackiert/lacado

Y essenza/wood/bois
Holz/madera

X laccato metallo/metal lacquered
laqué metal/Metalllackierung
lacado metal

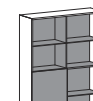

QQ

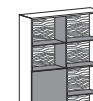

YQ

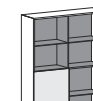

QX

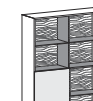

YX

supporti disponibili
supports available

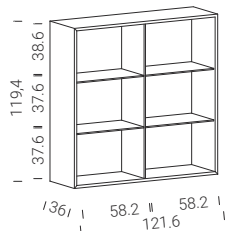

	QQ	YQ	QX	YX
MCOM0008	2175	2356	-	-



p. 65

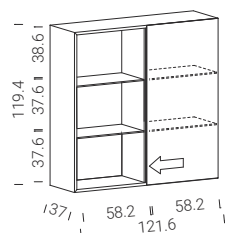

	QQ	YQ	QX	YX
MCOM0023	2679	2860	2811	2992



p. 65

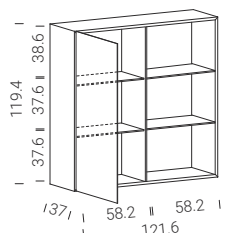

	QQ	YQ	QX	YX
MCOM0050	2703	2884	2824	3005



p. 65

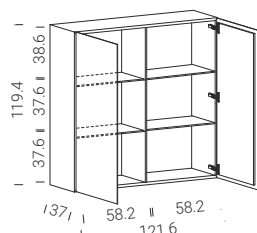

	QQ	YQ	QX	YX
MCOM0041	3130	3311	3372	3553



p. 65

supporti disponibili
supports available

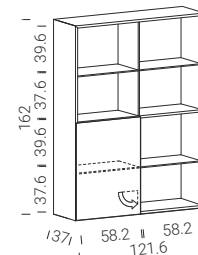

	QQ	YQ	QX	YX
MCOM0082	3105	3258	3194	3347



p. 65

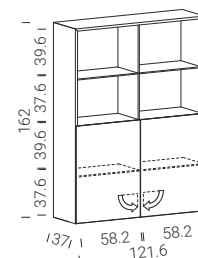

	QQ	YQ	QX	YX
MCOM0052	3447	3600	3625	3778



p. 65

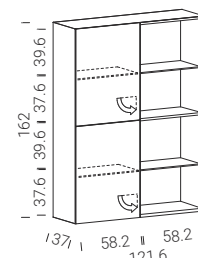

	QQ	YQ	QX	YX
MCOM0083	3447	3600	3625	3778



p. 65

i accessori non inclusi nel prezzo delle composizioni, disponibili pg.62-65/accessories not included in the price of the compositions, available on pages 62-65/accessoires non inclus dans le prix des compositions, disponibles pages 62-65/Accessoires, die nicht im Preis der Kompositionen enthalten sind, können auf den Seiten 62-65 eingesehen werden/acessorios no incluidos en el precio de las composiciones, disponibles pág.62-65

Q ■ laccato/lacquered/laqué
lackiert/lacado

Y ■ essenza/wood/bois
Holz/madera

X ■ laccato metallo/metal lacquered
laqué metal/Metallackierung
lacado metal

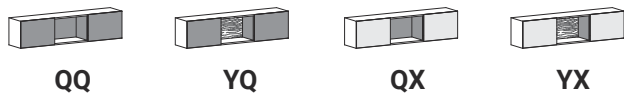

Q ■ laccato/lacquered/laqué
lackiert/lacado

Y ■ essenza/wood/bois
Holz/madera

X ■ laccato metallo/metal lacquered
laqué metal/Metallackierung
lacado metal

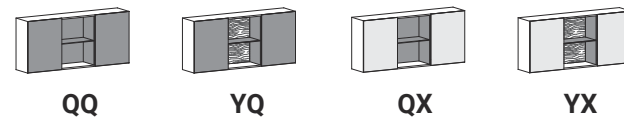

supporti disponibili
supports available



p. 65

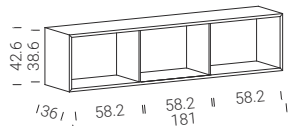

	QQ	YQ	QX	YX
MCOM0009	1629	1721	-	-



p. 65

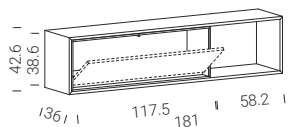

	QQ	YQ	QX	YX
MCOM0016	1547	1639	-	-



scrivitoio non incluso nel prezzo, info pagina 62
writing desk not included in the price, info on page 62
secrétaire non inclus dans le prix, info page 62
Schreibtisch, nicht im Preis inbegriffen, Info Seite 62
escritorio no incluido en el precio, página de información 62



p. 65

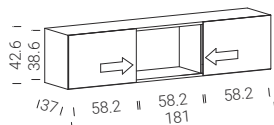

	QQ	YQ	QX	YX
MCOM0024	2183	2275	2327	2419

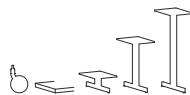

p. 65

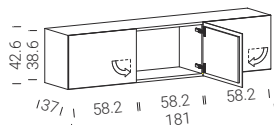

	QQ	YQ	QX	YX
MCOM0042	2465	2557	2644	2736

supporti disponibili
supports available



p. 65

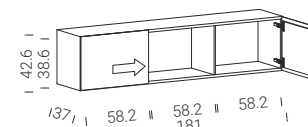

	QQ	YQ	QX	YX
MCOM0059	2188	2280	2191	2216



p. 65

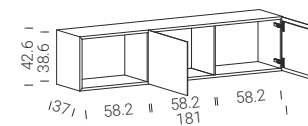

	QQ	YQ	QX	YX
MCOM0060	2240	2265	2360	2452



p. 65

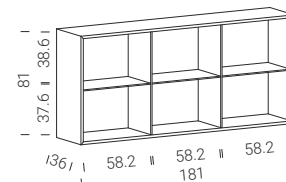

	QQ	YQ	QX	YX
MCOM0010	2267	2449	-	-



p. 65

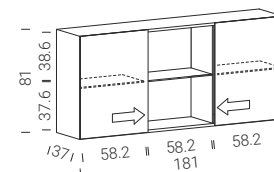

	QQ	YQ	QX	YX
MCOM0025	3045	3227	3247	3429

Q laccato/lacquered/laqué
lackiert/lacado

Y essenza/wood/bois
Holz/madera

X laccato metallo/metal lacquered
laqué metal/Metallackierung
lacado metal

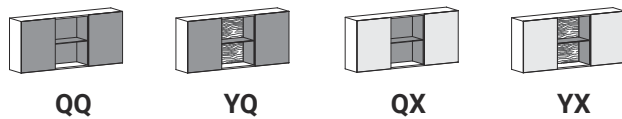

Q laccato/lacquered/laqué
lackiert/lacado

Y essenza/wood/bois
Holz/madera

X laccato metallo/metal lacquered
laqué metal/Metallackierung
lacado metal

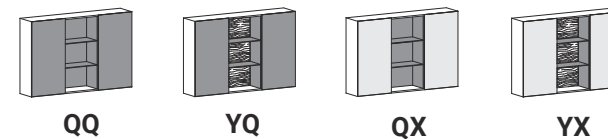

supporti disponibili
supports available

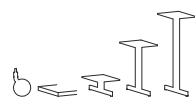

p. 65

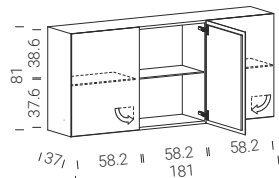

	QQ	YQ	QX	YX
MCOM0043	3475	3657	3741	3923

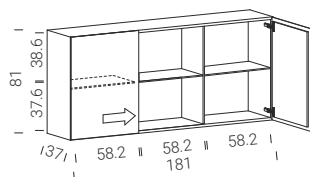

	QQ	YQ	QX	YX
MCOM0061	3077	3176	3257	3439

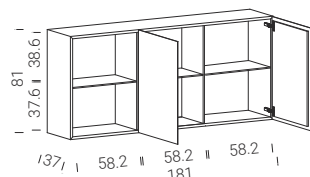

	QQ	YQ	QX	YX
MCOM0062	3046	3228	3224	3406

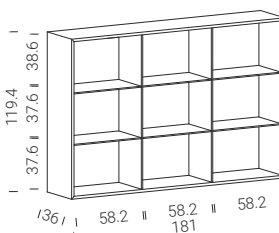

	QQ	YQ	QX	YX
MCOM0011	2839	3109	-	-



p. 65

supporti disponibili
supports available



p. 65

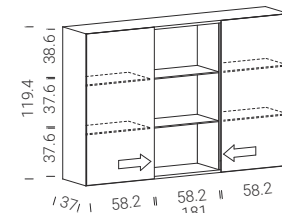

	QQ	YQ	QX	YX
MCOM0026	3847	4117	4111	4381

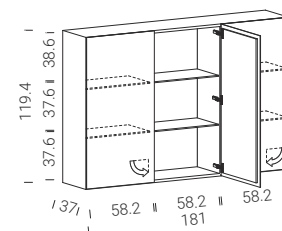

	QQ	YQ	QX	YX
MCOM0044	4417	4687	4775	5045



p. 65

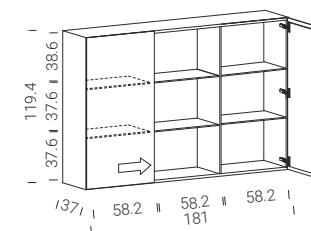

	QQ	YQ	QX	YX
MCOM0063	3871	4141	4124	4394



p. 65

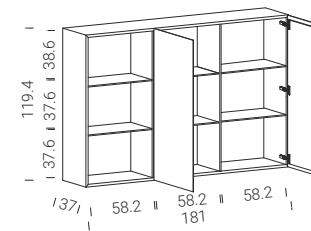



	QQ	YQ	QX	YX
MCOM0064	3974	4244	4216	4486





p. 65

i accessori non inclusi nel prezzo delle composizioni, disponibili pg.62-65/accessories not included in the price of the compositions, available on pages 62-65/accessoires non inclus dans le prix des compositions, disponibles pages 62-65
Accessorios, die nicht im Preis der Kompositionen enthalten sind, können auf den Seiten 62-65 eingesehen werden/accesorios no incluidos en el precio de las composiciones, disponibles pág.62-65

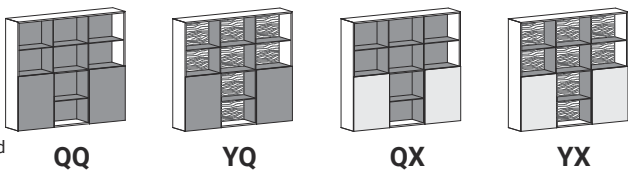
- Q**  laccato/lacquered/laqué
lackiert/lacado
- Y**  essenza/wood/bois
Holz/madera
- X**  laccato metallo/metal lacquered
laqué metal/Metalllackierung
lacado metal



- Q**  laccato/lacquered/laqué
lackiert/lacado
- Y**  essenza/wood/bois
Holz/madera
- X**  laccato metallo/metal lacquered
laqué metal/Metalllackierung
lacado metal

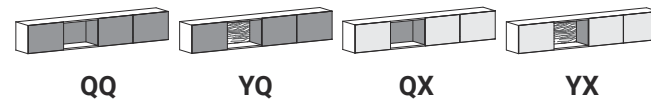

supporti disponibili
supports available

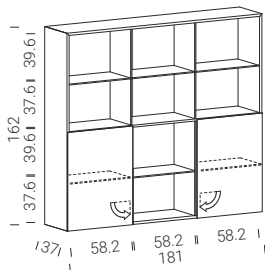

p. 65

	QQ	YQ	QX	YX
MCOM0084	4323	4531	4501	4709

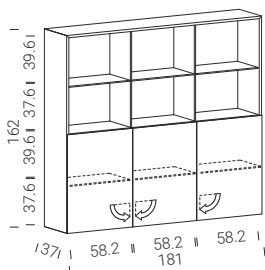

p. 65

	QQ	YQ	QX	YX
MCOM0066	4708	4916	4974	5182

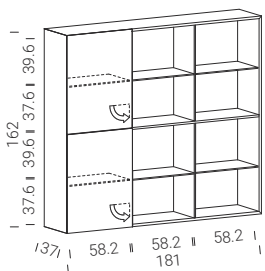

p. 65

	QQ	YQ	QX	YX
MCOM0085	4415	4623	4593	4801

supporti disponibili
supports available

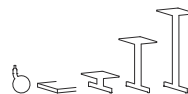

p. 65

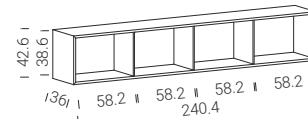

	QQ	YQ	QX	YX
MCOM0012	1903	2026	-	-



p. 65

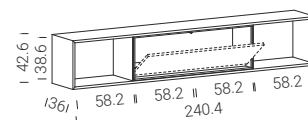

	QQ	YQ	QX	YX
MCOM0017	1821	1944	-	-



scrittoio non incluso nel prezzo, info pagina 62
writing desk not included in the price, info on page 62
secrétaire non inclus dans le prix, info page 62
Schreibtisch, nicht im Preis inbegriffen, Info Seite 62
escritorio no incluido en el precio, página de información 62



p. 65

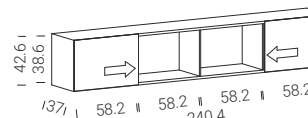

	QQ	YQ	QX	YX
MCOM0027	2457	2580	2601	2724



p. 65

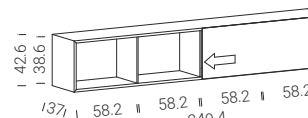

	QQ	YQ	QX	YX
MCOM0030	2310	2433	2416	2539

Q laccato/lacquered/laqué
lackiert/lacado

Y essenza/wood/bois
Holz/madera

X laccato metallo/metal lacquered
laqué metal/Metalllackierung
lacado metal

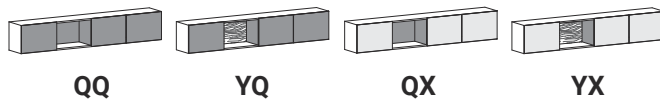

Q laccato/lacquered/laqué
lackiert/lacado

Y essenza/wood/bois
Holz/madera

X laccato metallo/metal lacquered
laqué metal/Metalllackierung
lacado metal

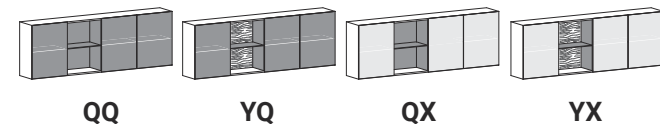

supporti disponibili
supports available

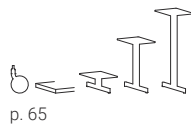

p. 65

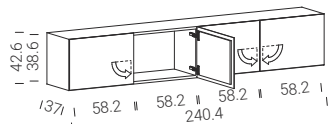

	QQ	YQ	QX	YX
MCOM0045	2983	3106	3221	3344

supporti disponibili
supports available

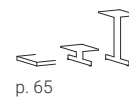

p. 65

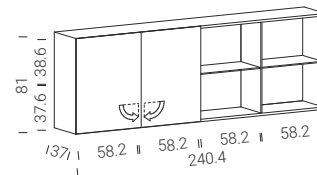

	QQ	YQ	QX	YX
MCOM0035	3531	3773	3708	3950

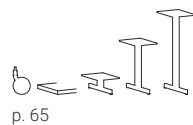

p. 65

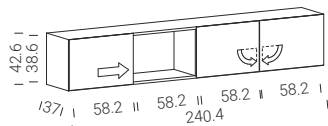

	QQ	YQ	QX	YX
MCOM0073	2753	2876	2944	3067

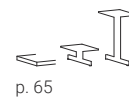

p. 65

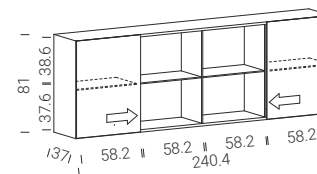

	QQ	YQ	QX	YX
MCOM0038	3492	3734	3694	3936

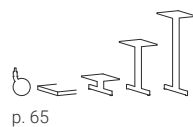

p. 65

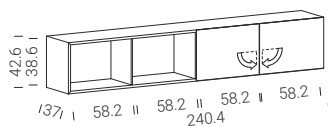

	QQ	YQ	QX	YX
MCOM0074	2476	2599	2595	2718

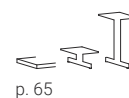

p. 65

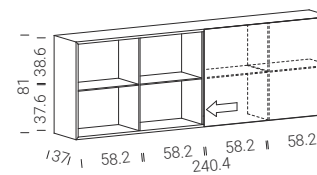

	QQ	YQ	QX	YX
MCOM0031	3295	3537	3446	3688

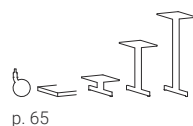

p. 65

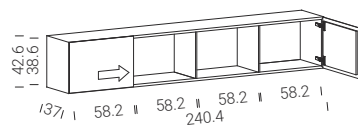

	QQ	YQ	QX	YX
MCOM0075	2497	2620	2629	2752

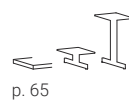

p. 65

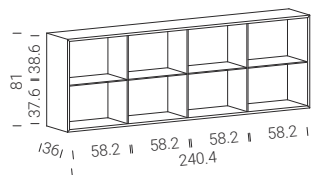

	QQ	YQ	QX	YX
MCOM0013	2714	2956	-	-

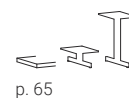

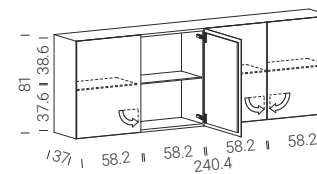

p. 65





	QQ	YQ	QX	YX
MCOM0046	4281	4523	4635	4877

i accessori non inclusi nel prezzo delle composizioni, disponibili pg.62-65/accessories not included in the price of the compositions, available on pages 62-65/accessoires non inclus dans le prix des compositions, disponibles pages 62-65
Accessoires, die nicht im Preis der Kompositionen enthalten sind, können auf den Seiten 62-65 eingesehen werden/acessorios no incluidos en el precio de las composiciones, disponibles pág.62-65

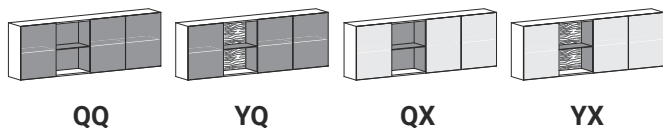
- Q**  laccato/lacquered/laqué
lackiert/lacado
- Y**  essenza/wood/bois
Holz/madera
- X**  laccato metallo/metal lacquered
laqué metal/Metalllackierung
lacado metal



- Q**  laccato/lacquered/laqué
lackiert/lacado
- Y**  essenza/wood/bois
Holz/madera
- X**  laccato metallo/metal lacquered
laqué metal/Metalllackierung
lacado metal

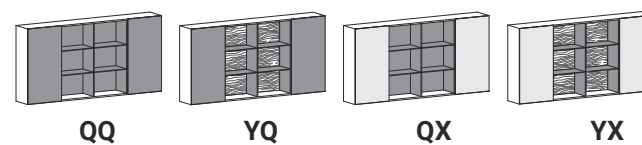

supporti disponibili
supports available



p. 65

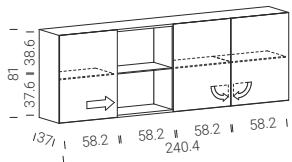

	QQ	YQ	QX	YX
MCOM0076	3920	4162	4198	4440



p. 65

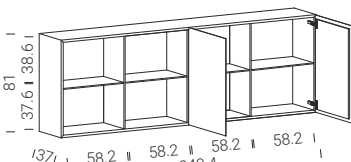

	QQ	YQ	QX	YX
MCOM0077	3551	3793	3728	3970



p. 65

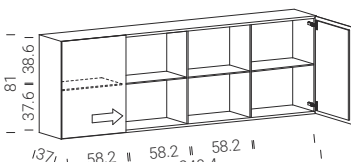

	QQ	YQ	QX	YX
MCOM0078	3514	3756	3704	3946



p. 65

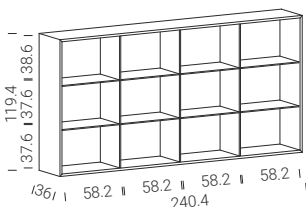

	QQ	YQ	QX	YX
MCOM0014	3435	3796	-	-

supporti disponibili
supports available



p. 65

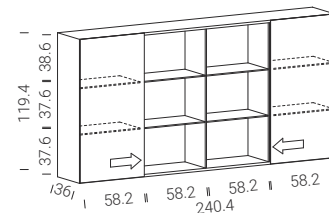

	QQ	YQ	QX	YX
MCOM0029	4443	4804	4707	5068



p. 65

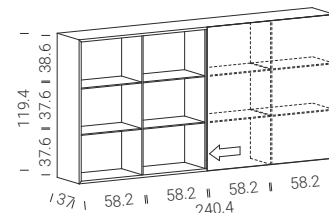

	QQ	YQ	QX	YX
MCOM0032	4205	4566	4405	4766



p. 65

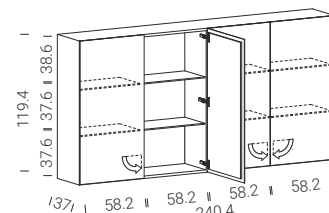

	QQ	YQ	QX	YX
MCOM0047	5477	5838	5951	6312

Q laccato/lacquered/laqué
lackiert/lacado

Y essenza/wood/bois
Holz/madera

X laccato metallo/metal lacquered
laqué metal/Metalllackierung
lacado metal

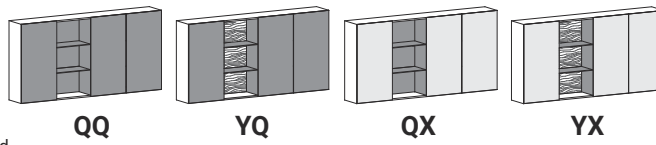

supporti disponibili
supports available

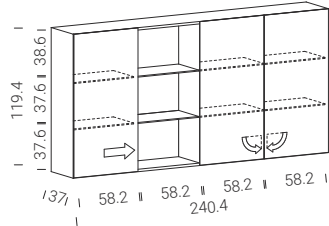

	QQ	YQ	QX	YX
MCOM0079	5010	5371	5247	5608



p. 65

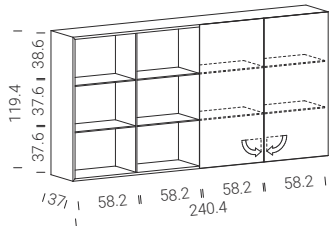

	QQ	YQ	QX	YX
MCOM0080	4506	4867	4743	5104



p. 65

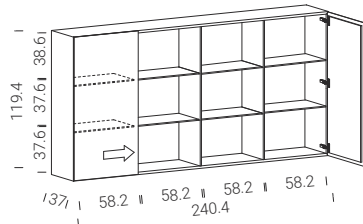

	QQ	YQ	QX	YX
MCOM0081	4486	4828	4720	5081



p. 65

è possibile affiancare o sovrapporre più moduli per ottenere altezze o lunghezze maggiori.
several modules can be combined or overlapped for greater lengths of heights.

plusieurs modules peuvent être placés côte à côte ou superposés pour obtenir des hauteurs ou des longueurs plus importantes.

Mehrere Module können für größere Höhen oder Längen neben- oder übereinander kombiniert werden.

se pueden unir o superponer varios módulos para obtener alturas o longitudes mayores.

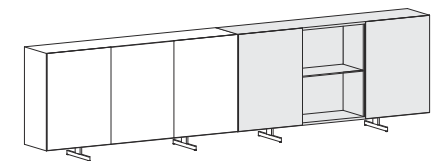
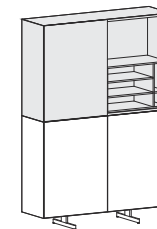
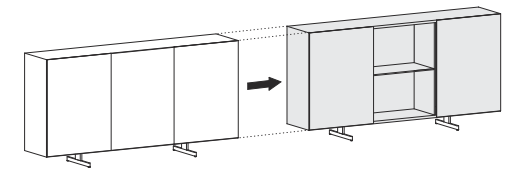
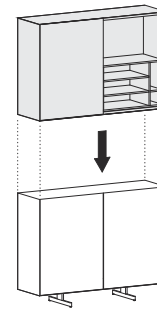

Y MDF legno/wood MDF/MDF bois
Holz MDF/DM madera

Y36 rovere/oak
Y34 noce/walnut

Q MDF laccato/lacquered MDF/MDF laqué
lackiertem MDF/DM lacado

Q05 bianco/white
Q16 seta/silk
Q17 corda/ecru
Q20 ghisa/cast-iron

Q14 antracite/anthracite
Q04 nero/black
Q21 bronzo/bronze

MONOLITH

CONTENITORI / CABIENTS / MODULES DE RANGEMENT / BEHÄLTER / CONTENEDORES

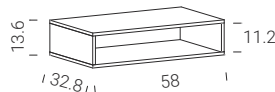
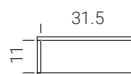
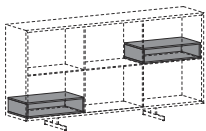

	kg max	Q	Y
* MCAP0002	8	270	345

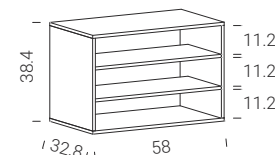
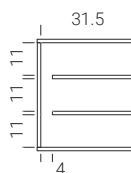
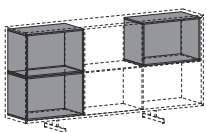

	kg max	Q	Y
* MCAP0004	8	391	548

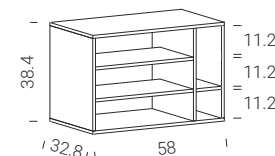
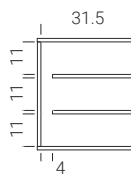

	kg max	Q	Y
* MCAP0005	8	442	607

SCRITTOIO / WRITING DESK / SECRÉTAIRE / SCHREIBTISCH / ESCRITORIO

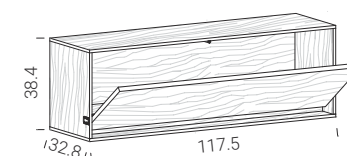
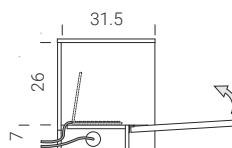
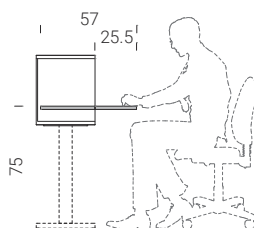
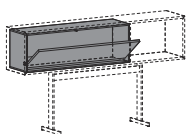

	kg max	Y
MCAR0001	15	1467

utilizzabile con/usable with
utilisable avec/verwendbar mit
utilizable con

MCOM0015
MCOM0016
MCOM0017

i passacavi incluso
cable glands included
passe-câbles inclus
einschließlich Kabeldurchlass
pasacables incluido

*

I contenitori non sono utilizzabili con ante battente.
The containers can not be used with hinged doors.
Les conteneurs ne peuvent pas être utilisés avec des portes battantes.
Die Behälter können nicht mit Flügeltüren verwendet werden.
Los contenedores no se pueden usar con puertas con bisagras.



Scrivitoio
Writing desk
Bureau
Schreibtisch
Escritorio

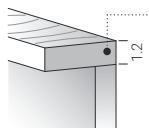

Y MDF legno/wood MDF/MDF bois
Holz MDF/DM madera

Y36 rovere/oak
Y34 noce/walnut

Q MDF laccato/lacquered MDF/MDF laqué
lackiertem MDF/DM lacado

Q05 bianco/white **Q14** antracite/anthracite
Q16 seta/silk **Q04** nero/black
Q17 corda/ecru **Q21** bronzo/bronze
Q20 ghisa/cast-iron

C plastica/plastic/plastique
Kunststoff/plástico

C04 silver/silver
C08 nero/black

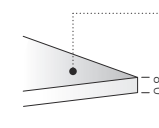

Q vetro temprato laccato/lacquered tempered glass
verre trempé laqué/Temperglas lackiert
cristal templado lacado

Q05 bianco/white **Q14** antracite/anthracite
Q16 seta/silk **Q04** nero/black
Q17 corda/ecru **Q21** bronzo/bronze
Q20 ghisa/cast-iron

V vetro temprato trasparente/transparent tempered glass
verre trempé transparent/Temperglas transparent
cristal templado transparente

V06 fumè/smoked
V07 float

CASSETTO / DRAWER / TIROIR / SCHUBLADE / CAJÓN

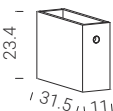
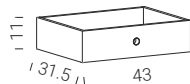
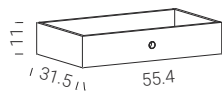
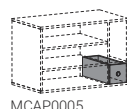
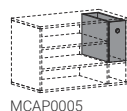
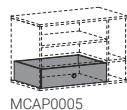
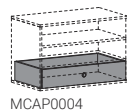
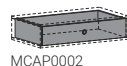

	A x B	kg max	Q	Y
MCSS0001	55.4 x 11	5	187	195

	A x B	kg max	Q	Y
MCSS0002	43 x 11	5	168	175

	A x B	kg max	Q	Y
MCSS0003	11 x 23.4	3	146	168

	A x B	kg max	Q	Y
MCSS0004	11 x 11	3	96	105

**RIPIANI ADDIZIONALI / ADDITIONAL SHELVES / ÉTAGÈRES ADDITIONNEL
ZUSÄTZLICHER BÖDEN / ESTANTES ADICIONAL**

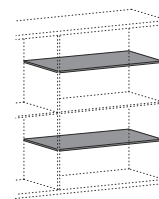

	A x 33	Q	V06	V07
MRIV0001	58.2 x 33	90	70	80

forature per supporti ripiano da eseguire in opera Ø5 mm
holes for shelf supports to be drilled Ø5 mm
trous pour supports d'étagères à réaliser sur place Ø5 mm
Löcher für Einlegebodenhalter sind mit Ø5 mm vorzunehmen
orificios para soportes de baldas a realizar in situ Ø5 mm

PASSACAVO / CABLE TIDY / PASSE-CÂBLES / KABELDURCHFÜHRUNG / PASACABLES

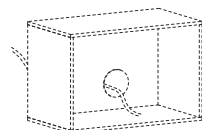

	C04 C08
XACC0014	8

La foratura è da eseguire in opera/holes are to be made during installation/le perçage est à effectuer lors du montage
Die Bohrung ist bei der Montage anzubringen/el perforado debe llevarse a cabo durante la instalación

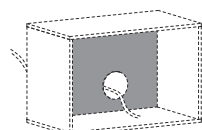

	C04 C08
XACC0028	60

passacavo con servizio di foratura/cable duct with perforation service/passe-câbles avec service de perçage
Kabeldurchführung mit Bohrmöglichkeit/pasacable con servicio de perforado

- L** HPL POLARIS®
L03 bianco/white
L10 grigio chiaro/light grey
L11 grigio scuro/dark grey
- HPL FENIX®
L08 grigio Londra/London grey
L06 nero/black

- Q** HPL laccato/lacquered HPL/HPL laqué
 lackiert HPL/HPL lacado
- Q16** seta/silk
Q17 corda/ecru
Q20 ghisa/cast-iron
Q14 antracite/anthracite
Q21 bronzo/bronze

- S** ceramica/ceramic/c eramique
 Keramik/cer amico
- S05** antracite/anthracite
S06 nero/black
S07 porfido/porfido
S08 cardoso/cardoso

- Y** HPL+ legno/wood/bois/Holz/madera
- Y36** rovere/oak
Y34 noce/walnut
Y37 rovere affumicato/smoked oak
Y38 rovere nero/black oak
Y40 frassino argilla/clay ash

- N** HPL+ ecotouch
- N01** sabbia/sand
N02 basalto/basalt

- C** HPL+ metallo/metal/m etal/Metall/metal
- C31** ottone/brass
C32 ottone brunito/burnished brass
C35 inox/inox
C36 inox scuro/dark inox
- D** HPL+ cemento/concrete/ciment
 zement/cemento
- D01** bianco calce/lime white
D02 grigio Portland/Portland grey
D03 nero/black

TOP / TOP / PLATEAU / PLATTE / PLANO

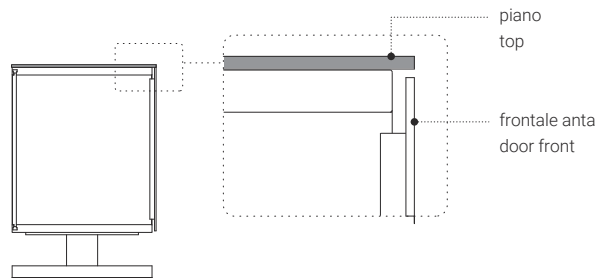
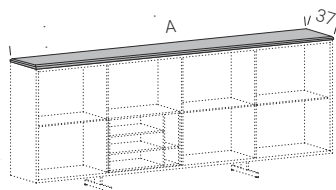

Si consiglia l'utilizzo del top a per protezione della scocca e per un miglior raccordo geometrico tra scocca e anta.
 We recommend the use of the top in order to protect the body and for a better geometric connection between the body and the door.
 Nous conseillons l'utilisation du plateau pour la protection de la coque et pour un meilleur raccordement g om etrique entre la coque et le vantail.
 Wir empfehlen Ihnen die Verwendung eines Tops – einerseits, um das Gestell zu sch utzen und andererseits, um eine bessere geometrische Verbindung zwischen Gestell und T urfl ugel zu erwirken.
 Recomendamos el uso de la parte superior a para proteger el cuerpo y para una mejor conexi n geom trica entre el cuerpo y la puerta.

	A x 37	L03 L06	L08 L10 L11	Q	S	Y	N	C	D
MRIP0011	121.6 x 37	205	219	180	238	235	215	317	240
MRIP0012	181 x 37	293	314	257	340	337	308	455	343
MRIP0013	240.4 x 37	384	411	293	445	441	403	595	449

KIT PER APPOGGIO MARMO / MARBLE SHELF SUPPORT KIT / KIT DE SUPPORT D' TAG RE EN MARBRE
 ST TZSATZ F R MARMORREGALE / KIT DE SOPORTE DE ESTANTER A DE M RMOL

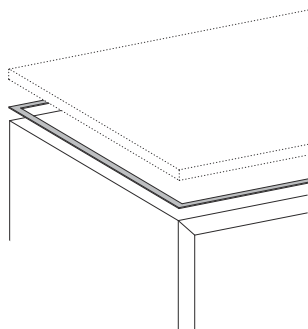

	A x B	
MACC0018	121.6 x 37	24
MACC0019	181 x 37	32
MACC0020	240.4 x 37	42

Si consiglia di reperire il top in marmo localmente e di utilizzare i kit di appoggio MACC0018/MACC0019/MACC0020. Il kit   composto da un materassino in neoprene adesivo che pu  essere tagliato e applicato in opera.
 We recommend that the marble top be obtained locally and that the MACC0018/MACC0019/MACC0020 support kit be used. The kit consists of an adhesive neoprene mat that can be cut and applied on site.
 Nous vous conseillons de vous procurer le plateau en marbre sur place et d'utiliser les kits de support MACC0018/MACC0019/MACC0020. Le kit se compose d'un petit matelas en n opr ne adh sif qui peut  tre d coup  et appliqu  sur place.
 Es empfiehlt sich, die Marmorplatte (Top) vor Ort, unter Verwendung des Befestigungssets MACC0018/MACC0019/MACC0020, aufzubringen. Das Set beinhaltet eine selbstklebende Neoprenmatte, die bei Bedarf zugeschnitten und aufgeklebt werden kann.
 Recomendamos obtener la encimera de m rmol en una tienda local y usar los kits de soporte MACC0018/MACC0019/MACC0020. El kit consiste en una estera adhesiva de neopreno que se puede cortar y aplicar en el sitio.

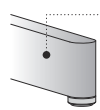

C acciaio verniciato/painted steel/acier peint
lackierter Stahl/acero pintado

- C12** bianco/white
- C21** seta/silk
- C23** corda/ecru
- C30** ghisa/cast-iron
- C14** antracite/antracite
- C08** nero/black
- C29** bronzo/bronze

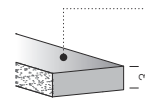

Q laccato/ lacquered/laqué
lackiert/lacado

- Q05** bianco/white
- Q16** seta/silk
- Q17** corda/ecru
- Q20** ghisa/cast-iron
- Q14** antracite/antracite
- Q04** nero/black
- Q21** bronzo/bronze

SUPPORTI / SUPPORTS / SUPPORTS / TRÄGER / APOYOS

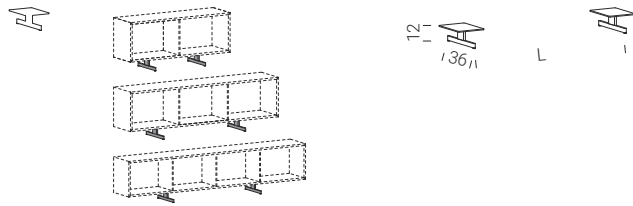

	L	C
MACC0002	59	277
MACC0002	98.5	277
MACC0002	117	277

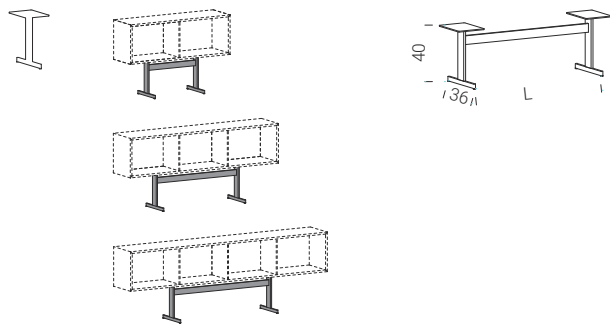

	L	C
MACC0004	59	332
MACC0005	98.5	337
MACC0006	117	341

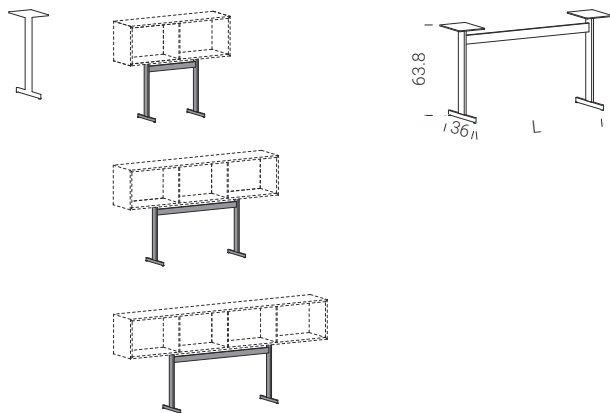

	L	C
MACC0008	59	351
MACC0009	98.5	365
MACC0010	117	362

BASE / BASE / BASE / BASIS / BASE

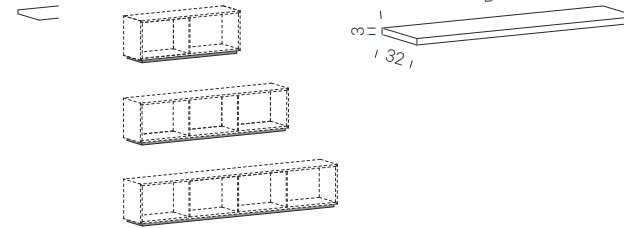

	L	Q
MACC0012	115.6	161
MACC0013	175	212
MACC0014	234.4	263

SET 4 RUOTE / SET OF 4 WHEELS / KIT 4 ROUES / SET 4 RÄDER / SET 4 RUEDAS

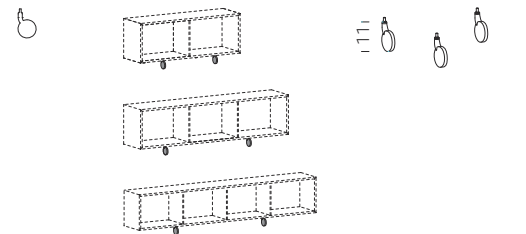

	C12 C08
MACC0015	203

XY

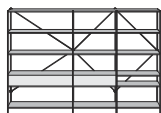

IL BREVETTO XY CONSENTE DI POSIZIONARE I RIPIANI LUNGO L'ASSE VERTICALE Y E LE COPPIE DI PROFILI PORTANTI LUNGO L'ASSE ORIZZONTALE X. IL POSIZIONAMENTO IN X ED Y AVVIENE IN CONTINUO, SENZA POSIZIONI PREDEFINITE. CIÒ COSTITUISCE UN'OSSATURA PORTANTE IN GRADO DI ESSERE ALLESTITA CON SCHIENE, FIANCHI, ANTE A RIBALTA, ANTE A BATTENTE, CASSETTIERE.

The patented XY system enables you to position the shelves along vertical Y-axis and the pairs of load-bearing profiles along horizontal X-axis. Positioning along X and Y is completely free, without any preset positions. This creates a load-bearing framework that can be completed with backs, sides, tilting or leaf doors, drawer units

Le brevet XY permet de positionner les étagères le long de l'axe vertical Y et les paires de profilés portants le long de l'axe horizontal X. Le positionnement suivant X et Y s'effectue en continu, sans positions prédéfinies. Ceci réalise une structure portante susceptible d'être équipée de fonds, côtés, portes à rabattant, portes à battant, kits de tiroirs.

Das Patent XY ermöglicht es, die Böden längs der vertikalen Y-Achse und die tragenden Profilaare längs der horizontalen X-Achse zu positionieren. Dabei kann die Positionierung auf X und Y an jeder Stelle ohne voreingestellte Positionen erfolgen. Auf diese Weise wird eine tragende Struktur gebildet, die mit Rück- und Seitenwänden, Klapp- und Flügeltüren, Schubladenelementen.

La patente XY permite colocar los estantes a lo largo del eje vertical Y y las parejas de perfiles portantes a lo largo del eje horizontal X. La colocación en X e Y se produce en continuo, sin posiciones previamente definidas. Esto forma un armazón portante capaz de albergar dorso, laterales, puertas abatibles, puertas de batiente, cajoneras





PRODUCT CONCEPT

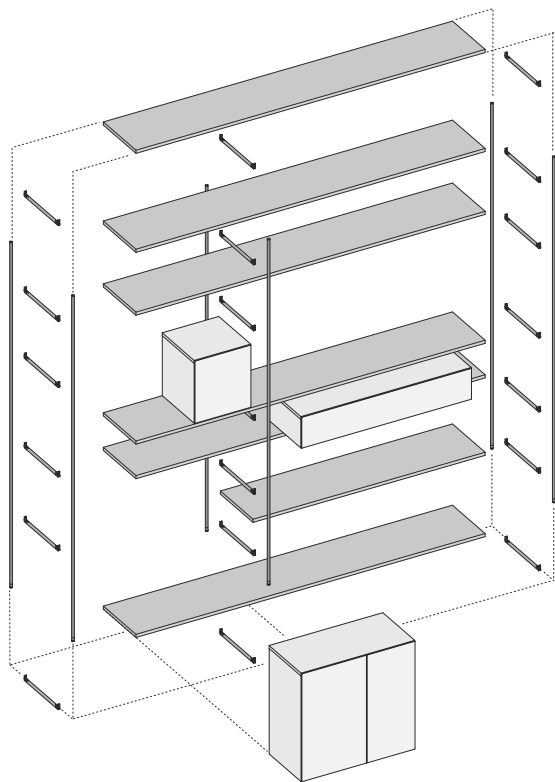

L modules
36.5 – 73 – 109 - 145

H modules
riducibile al centimetro
reducible to the centimetre
réductible au centimètre
verkürzbar auf den Zentimeter
reducible al centimetro

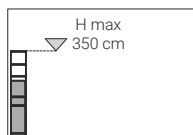
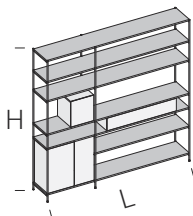

Pavimento / parete
Floor / wall
Sol / mur
Boden / Wand
Suelo / pared

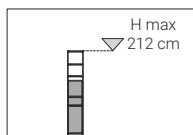

Centro stanza
Room divider units
Centre de la pièce
Zimmermitte
Centro de la habitación

Ripiani hanno libera posizione in altezza, (al cm).
Contentori hanno libera posizione in altezza e larghezza (al cm).

Shelves can be positioned at any height, (to the cm).
Containers can be positioned at any height, (to the cm).

Les étagères peuvent être positionnées librement en hauteur (au cm près). Les conteneurs peuvent être positionnés librement en hauteur et en largeur (au cm près).

Einlegeböden sind in der Höhe frei einsetzbar (auf den cm). Behälter sind in der Höhe und in der Breite frei einsetzbar (auf den cm).

Los estantes tienen posicionamiento libre en altura (al cm). Los contenedores tienen posicionamiento libre en altura y anchura (al cm).

Le composizioni non fissate a parete richiedono l'utilizzo del kit tiranti.

Compositions that are not fastened to the wall require the use of the tie-rods kit.

Les compositions qui ne sont pas fixées au mur nécessitent l'utilisation du kit tirants.

Nicht an der Wand befestigte Kompositionen benötigen einen Zugankersatz.

Los componentes no fijados a la pared, requieren el uso del kit de tirantes.



Sistema brevettato
Patented system
Système breveté
Patentiertes system
Sistema patentado

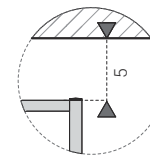

distanza minima dal soffitto 5 cm
minimum distance from ceiling 5 cm
distance minimale du plafond 5 cm
Mindestabstand von Decke 5 cm
distancia mínima del techo 5 cm

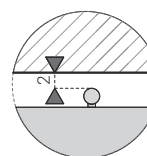
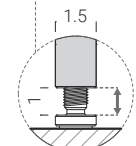
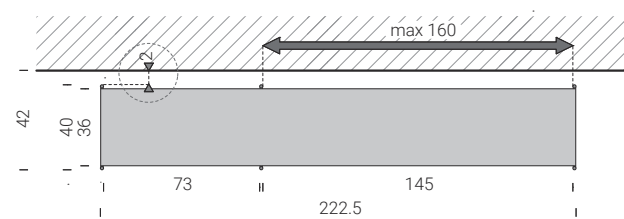
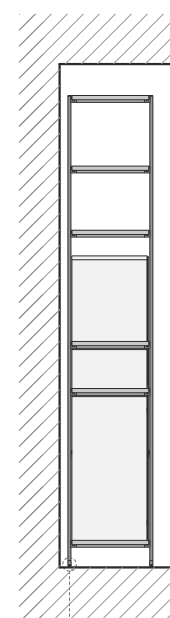
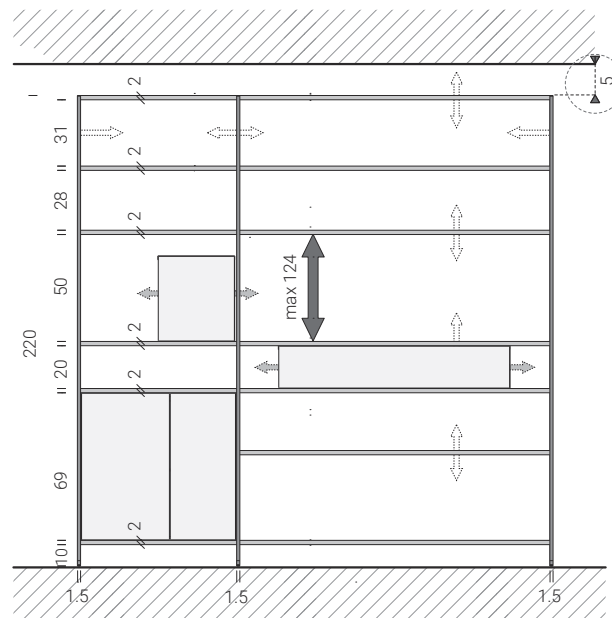

distanza minima dalle pareti 2 cm., i supporti a parete sono sempre inclusi.
minimum distance from walls 2 cm., the wall supports are always included.
distance minimale des murs 2 cm., les supports muraux sont toujours inclus.
Mindestabstand von Wänden 2 cm., die Wandhalterungen sind immer im Lieferumfang inbegriffen.
distancia mínima de las paredes 2 cm., los soportes de pared siempre van incluidos.

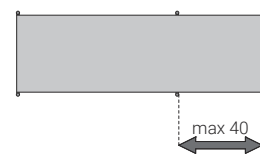

per i ripiani lo sbalzo massimo consentito è di 40 cm.
for shelves, the maximum permitted cantilever is 40 cm.
pour les étagères, le porte-à-faux maximum autorisé est de 40 cm.
Für die Einlegeböden ist ein maximaler Überstand von 40 cm zulässig.
para los estantes el voladizo máximo permitido es de 40 cm.

XY

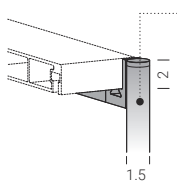

C alluminio verniciato/painted aluminium/aluminium peint
lackierter Aluminium/aluminio pintado

- C12** bianco/white
- C21** seta/silk
- C30** ghisa/cast-iron
- C08** nero/black
- C29** bronzo/bronze

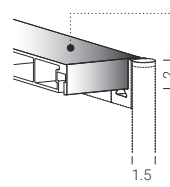

C alluminio verniciato/painted aluminium/aluminium peint
lackierter Aluminium/aluminio pintado

- C12** bianco/white
- C21** seta/silk
- C30** ghisa/cast-iron
- C08** nero/black
- C29** bronzo/bronze

COPPIA DI PROFILI VERTICALI / PAIR OF UPRIGHT PROFILES
PAIRE DE PROFILS VERTICAUX / EIN PAAR VERTIKALE PROFILE
PAR PERFILES VERTICALES

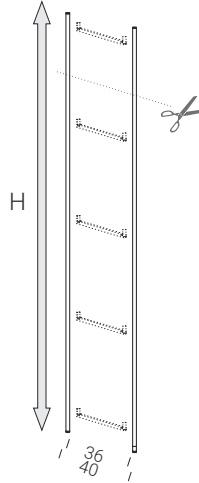
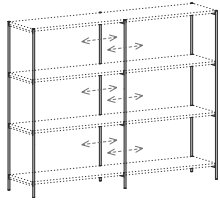

	H	C
XMON0001	54	87
XMON0001	96	97
XMON0001	138	111
XMON0001	180	121
XMON0001	222	132
XMON0001	264	146
XMON0001	306	153
XMON0001	348	164

SUPPORTO RIPIANO / SHELF SUPPORT / SUPPORT D'ÉTAGÈRE
BORDHALTER / SOPORTE PARA ESTANTE

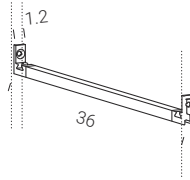
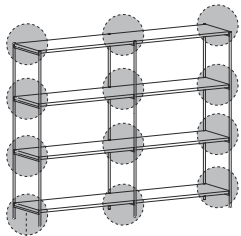

	C
XNOD0001	30

XNOD0001

RIPIANO / SHELF / ÉTAGÈRE / BÖDEN / ESTANTE

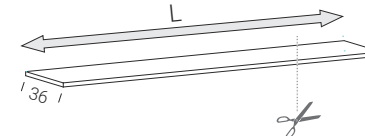
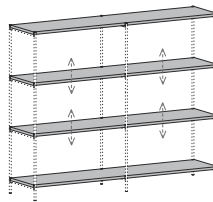

	L	C
XRIP0001	39.5	176
XRIP0001	76	231
XRIP0001	114	284
XRIP0001	150.5	347
XRIP0001	186.5	403
XRIP0001	225	477
XRIP0001	261	527
XRIP0001	297	584
XRIP0001	333	635



L < 100cm 50 Kg max
L > 100cm 35 Kg max



Per dimensioni maggiori di 333 cm è possibile unire 2 ripiani in corrispondenza di una spalla.
For dimensions greater than 333 cm, two shelves can be joined together in correspondence with a support profile.
Pour toute dimension supérieure à 333 cm il est possible de joindre 2 étagères au niveau d'un montant.
Für Abmessungen über 333 cm können zwei Böden auf Höhe eines Widerlagers vereint werden.
Para dimensiones mayores de 333 cm se pueden unir dos estantes combinados con una percha.



composizione a modulo
modular composition
composition à module
Modulkombination
composición de módulos

composizione a modulo/libera
modular/free composition
composition à module/libre
Modul-/freie Kombination
composición de módulos/libre

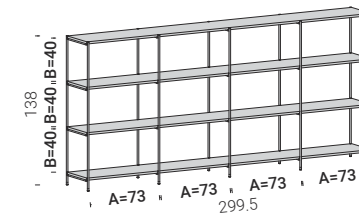

standard moduls
A = 36.5 / 73 / 109 / 145
B = 20 / 40 / 69 / 98

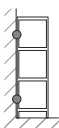
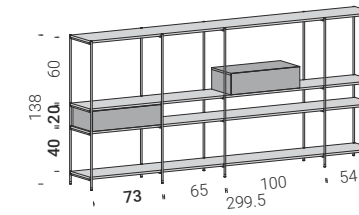
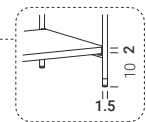

I supporti a parete sono sempre inclusi
The wall supports are always included
Les supports muraux sont toujours inclus
Die Wandhalterungen sind immer im Lieferumfang
Los soportes de pared siempre van incluidos



disponibili riduzioni a misura
custom reductions available
Verkürzungen auf Maß erhältlich
réductions sur mesure disponibles
disponibles reducciones a medida



XRID0010
+30 €



riduzione ripiano (prezzo per 1 taglio)
shelf reduction (price for 1 cut)
réduction étagère (prix pour 1 coupe)
Reduzierung (Preis für 1 Schnitt)
reducción de estante (precio por 1 corte)

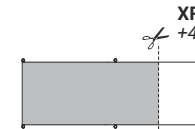

XRID0011
+40 €

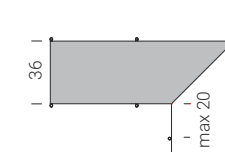

XRID0001
+60 €

TIRANTI / RODS / TIRANTS / STAHLSTANGEN / TIRANTES 

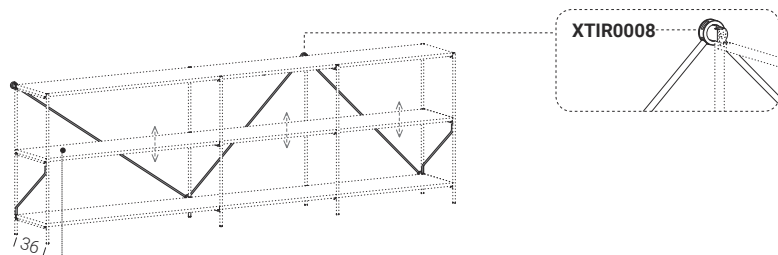

I ripiani sono liberamente spostabili.
The shelves are shiftable.
Les étagères peuvent être déplacées librement.
Die Fächer sind leicht verstellbar.
Los estantes se pueden desplazar libremente

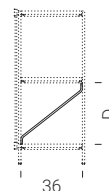
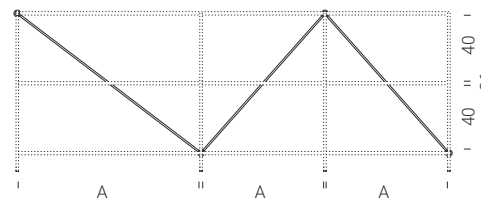
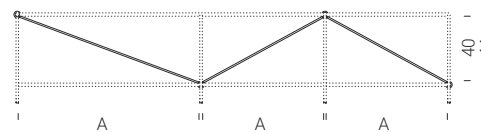

	C
* XTIR0008	68

	A x 44	C
XTIR0015	36.5 x 44	30
XTIR0016	73 x 44	34
XTIR0017	109 x 44	38
XTIR0018	145 x 44	42

	A x 86	C
XTIR0010	36.5 x 86	40
XTIR0011	73 x 86	44
XTIR0012	109 x 86	48
XTIR0013	145 x 86	52

	36 x D	C
XTIR0014	36 x 20	35
XTIR0006	36 x 40	40

FISSAGGIO A SOFFITTO (SET DI 2) / CEILING ATTACHMENT (SET OF 2) / FIXATION AU PLAFOND (KIT DE 2) / DECKENBEFESTIGUNG (2 STÜCK IM SET) / SUJECIÓN AL TECHO (SET DE 2)

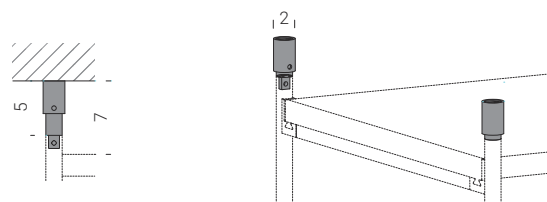

	C
XADA0001	58

ADATTATORE PER PARETE E SOFFITTO IN CARTONGESSO / ADAPTOR FOR PLASTERBOARD WALL OR CEILING ADAPTATEUR EN "PLACOPLÂTRE" POUR MONTAGE MURAL ET AU PLAFOND RÄDERN ADAPTER FÜR WAND ODER DECKE AUS GIPSKARTON ADAPTADOR PARA PARED O TECHO DE CARTÓN-YESO

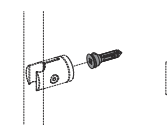
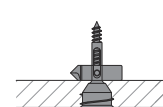

XADA0005	14
----------	----



I tiranti sono obbligatori per composizioni free standing.
The tie rods are required for free standing compositions.
Les tirants sont nécessaires pour les compositions autoportantes.
Die Zuganker sind für freistehende Zusammensetzungen notwendig.
Los tirantes son necesarios para composiciones independientes.



Il raccordo può accogliere 1,2 o 4 tiranti
the joint can house 1, 2 or 4 tie rods
Le raccord peut accueillir 1, 2 ou 4 tirants
Der Anschluss kann 1, 2 oder 4 Zuganker aufnehmen
El empalme puede acoplar 1,2 ó 4 tirantes



dima di installazione per composizioni XY a pg. 79
Installation template for XY compositions on pg. 79
gabarit d'installation pour compositions XY p. 79
Installationschablone für Kombinationen XY auf S. 79
plantilla de instalación para composiciones XY en pág. 79

COMPOSIZIONI A PARETE / WALL-MOUNTED COMPOSITIONS / COMPOSITIONS MURALES / WANDKOMPOSITIONEN / COMPOSICIÓN DE PARED

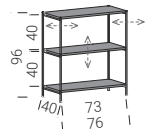

XCOM0025
1127

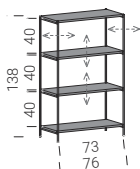

XCOM0026
1446

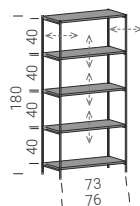

XCOM0027
1757

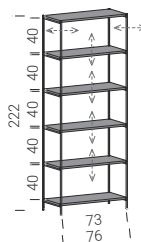

XCOM0028
2070

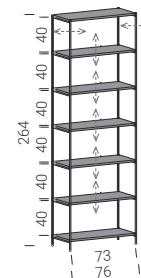

XCOM0029
2389

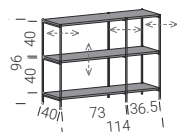

XCOM0030
1473

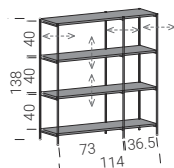

XCOM0031
1889

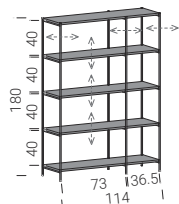

XCOM0032
2293

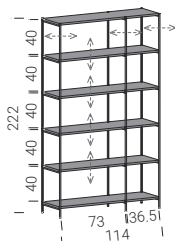

XCOM0033
2700

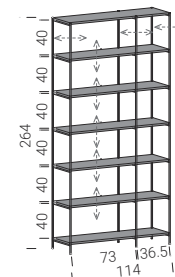

XCOM0034
3116

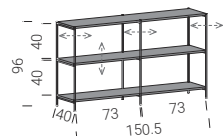

XCOM0035
1662

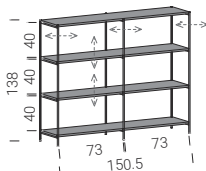

XCOM0036
2141

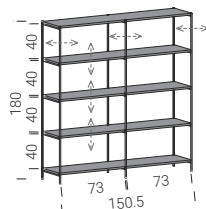

XCOM0037
2608

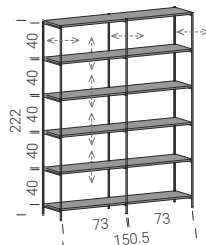

XCOM0038
3078

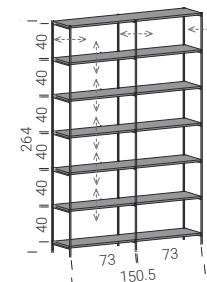

XCOM0039
3557

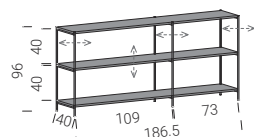

XCOM0040
1830

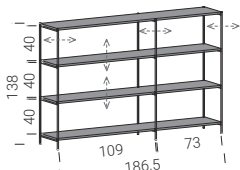

XCOM0041
2365

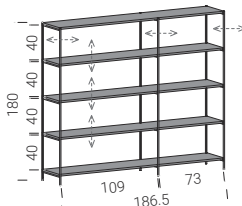

XCOM0042
2888

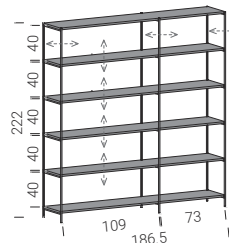

XCOM0043
3414

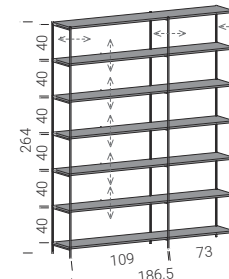

XCOM0044
3949

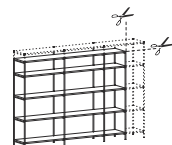

le composizioni possono essere ridotte in altezza e larghezza.
the compositions can be reduced in height and width.
les compositions peuvent être réduites en hauteur et en largeur.
die Zusammenstellungen können in der Höhe und Breite verkleinert werden.
las composiciones pueden reducirse en altura y anchura.



riduzione ripiano/coppia di profili verticali (prezzo per 1 taglio)
shelf/pair of upright profiles reduction (price for 1 cut)
réduction étagère/paire de profils verticaux (prix pour 1 coupe)
Reduzierung des Fachbodens/ein Paar vertikale Profile (Preis für 1 Schnitt)
reducción de estante/par perfiles verticales (precio por 1 corte)



XRID0010
+30 €



XRID0011
+40 €

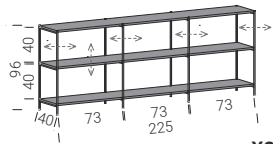

XCOM0045
2239

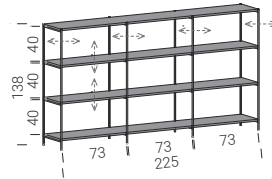

XCOM0046
2892

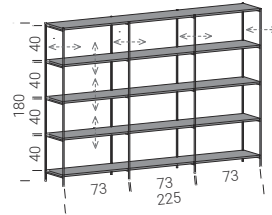

XCOM0047
3529

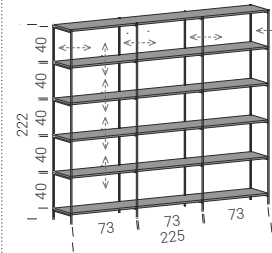

XCOM0048
4170

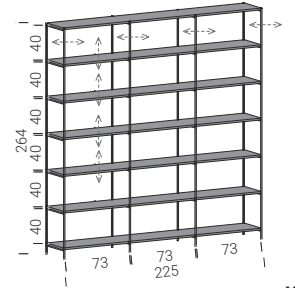

XCOM0049
4823

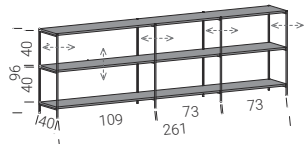

XCOM0050
2389

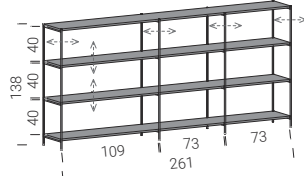

XCOM0051
3092

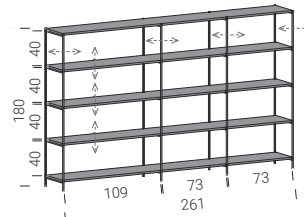

XCOM0052
3779

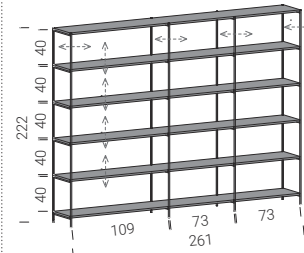

XCOM0053
4470

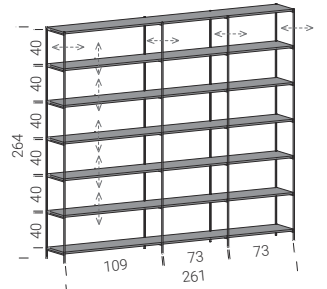

XCOM0054
5173

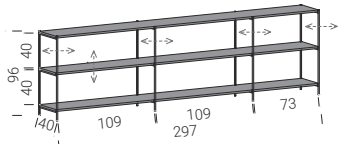

XCOM0055
2560

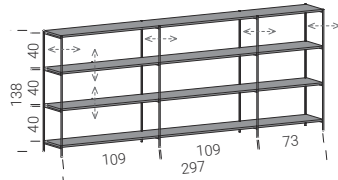

XCOM0056
3320

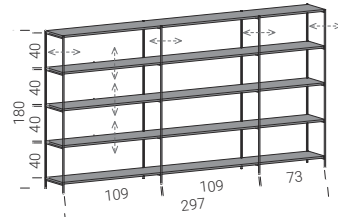

XCOM0057
4064

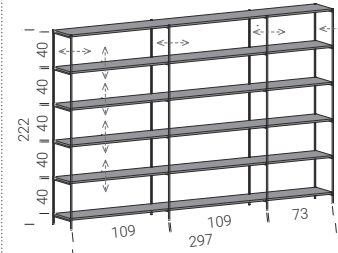

XCOM0058
4812

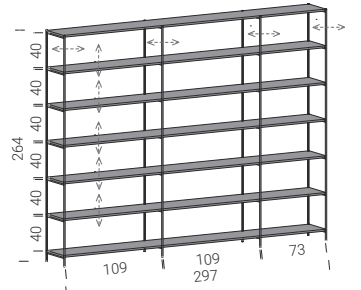

XCOM0059
5572

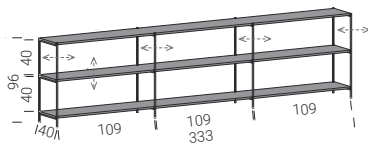

XCOM0060
2713

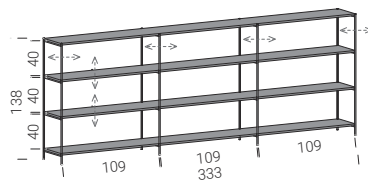

XCOM0061
3524

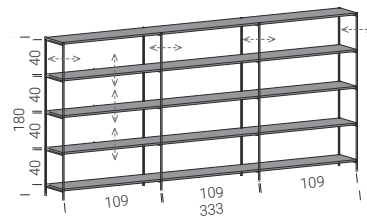

XCOM0062
4319

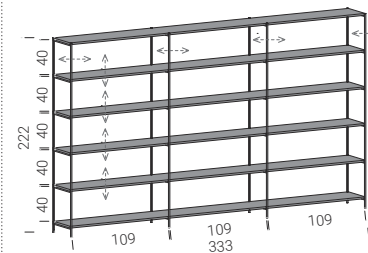

XCOM0063
5118

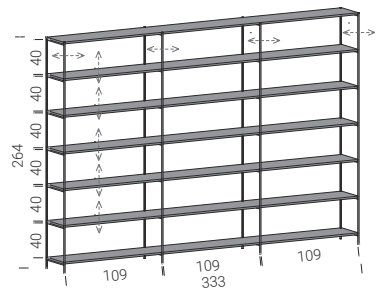

XCOM0064
5929

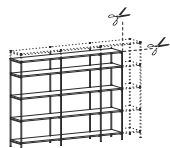

le composizioni possono essere ridotte in altezza e larghezza.
the compositions can be reduced in height and width.
les compositions peuvent être réduites en hauteur et en largeur.
die Zusammenstellungen können in der Höhe und Breite verkleinert werden.
las composiciones pueden reducirse en altura y anchura.



riduzione ripiano/coppia di profili verticali (prezzo per 1 taglio)
shelf/pair of upright profiles reduction (price for 1 cut)
réduction étagère/paire de profils verticaux (prix pour 1 coupe)
Reduzierung des Fachbodens/ein Paar vertikale Profile (Preis für 1 Schnitt)
reducción de estante/par perfiles verticales (precio por 1 corte)

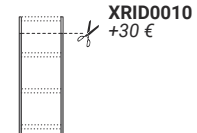

XRID0010
+30 €

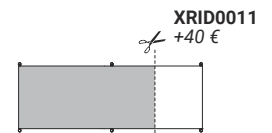

XRID0011
+40 €

XY

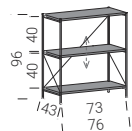

XCOM0065
1677

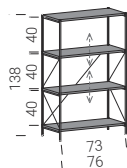

XCOM0066
1776

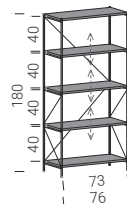

XCOM0067
2189

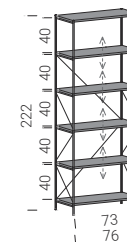

XCOM0068
2582

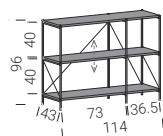

XCOM0069
1821

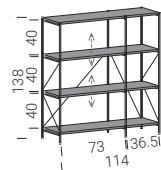

XCOM0070
2317

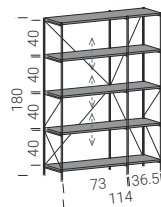

XCOM0071
2921

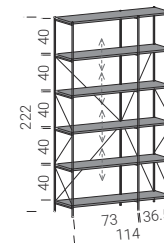

XCOM0072
3408

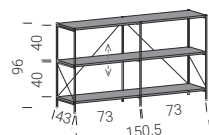

XCOM0073
2014

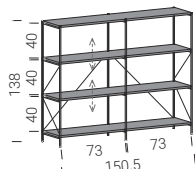

XCOM0074
2573

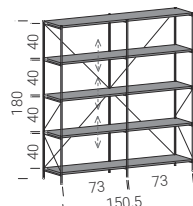

XCOM0075
3244

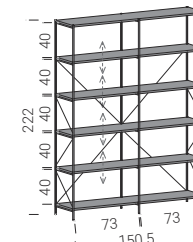

XCOM0076
3794

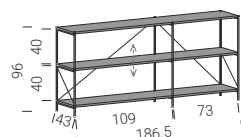

XCOM0077
2186

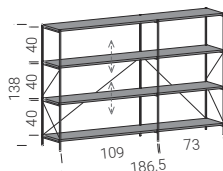

XCOM0078
2801

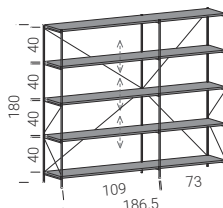

XCOM0079
3532

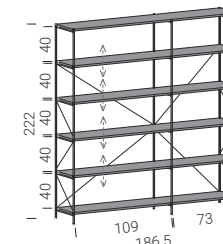

XCOM0080
4138

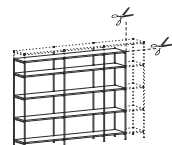

le composizioni possono essere ridotte in altezza e larghezza.
the compositions can be reduced in height and width.
les compositions peuvent être réduites en hauteur et en largeur.
die Zusammenstellungen können in der Höhe und Breite verkleinert werden.
las composiciones pueden reducirse en altura y anchura.



riduzione ripiano/coppia di profili verticali (prezzo per 1 taglio)
shelf/pair of upright profiles reduction (price for 1 cut)
réduction étagère/paire de profils verticaux (prix pour 1 coupe)
Reduzierung des Fachbodens/ein Paar vertikale Profile (Preis für 1 Schnitt)
reducción de estante/par perfiles verticales (precio por 1 corte)



XRID0010
+30 €



XRID0011
+40 €

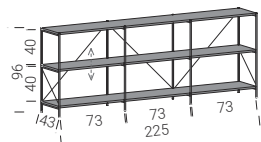

XCOM0081
2693

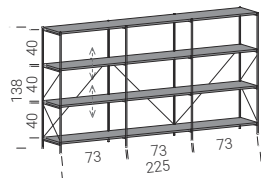

XCOM0082
3426

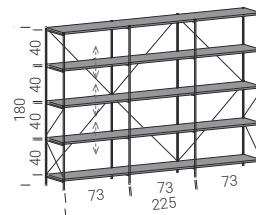

XCOM0083
4301

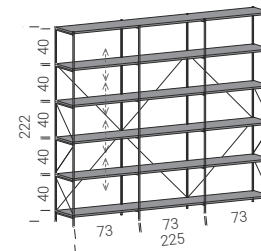

XCOM0084
5022

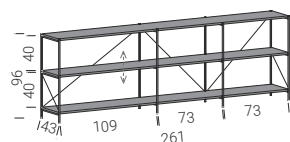

XCOM0085
2847

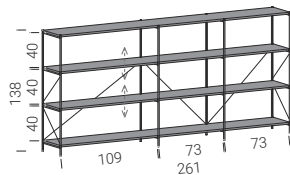

XCOM0086
3630

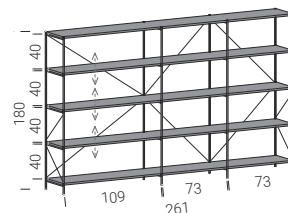

XCOM0087
4559

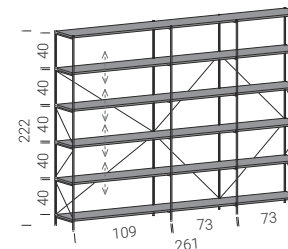

XCOM0088
5330

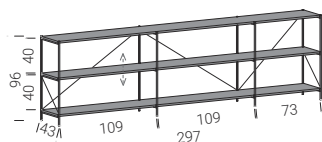

XCOM0089
3022

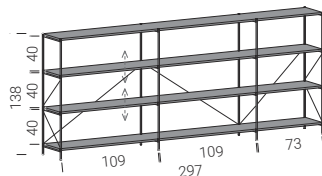

XCOM0090
3862

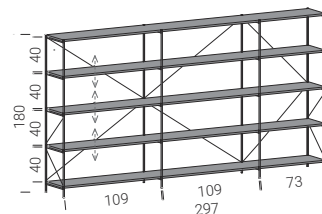

XCOM0091
4852

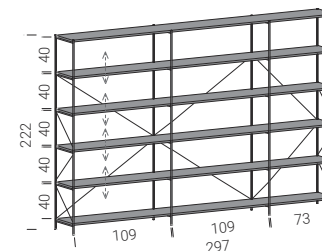

XCOM0092
5680

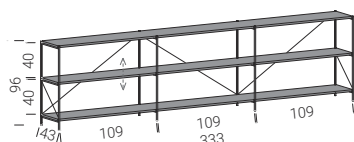

XCOM0093
3179

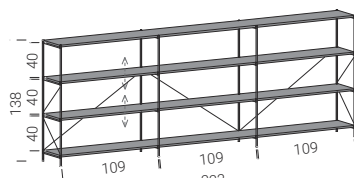

XCOM0094
4070

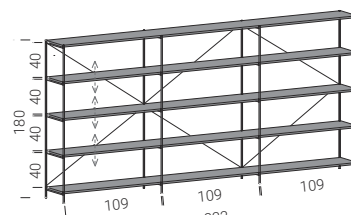

XCOM0095
5115

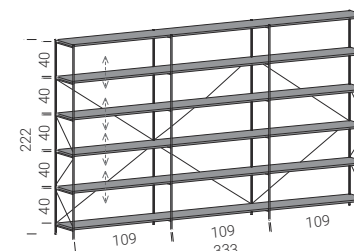

XCOM0096
5994

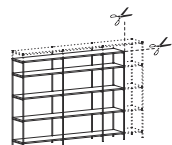

le composizioni possono essere ridotte in altezza e larghezza.
the compositions can be reduced in height and width.
les compositions peuvent être réduites en hauteur et en largeur.
die Zusammenstellungen können in der Höhe und Breite verkleinert werden.
las composiciones pueden reducirse en altura y anchura.



riduzione ripiano/coppia di profili verticali (prezzo per 1 taglio)
shelf/pair of upright profiles reduction (price for 1 cut)
réduction étagère/paire de profils verticaux (prix pour 1 coupe)
Reduzierung des Fachbodens/ein Paar vertikale Profile (Preis für 1 Schnitt)
reducción de estante/par perfiles verticales (precio por 1 corte)



XRID0010
+30 €



XRID0011
+40 €

Q laccato/lacquered/laqué
lackiert/lacado

Y essenza/wood/bois
Holz/madera

X laccato metallo/metal lacquered
laqué metal/Metallackierung
lacado metal

Q05 bianco/white
Q16 seta/silk
Q17 corda/ecru
Q20 ghisa/cast-iron
Q14 antracite/anthracite
Q04 nero/black
Q21 bronzo/bronze

Y36 rovere/oak
Y34 noce/walnut
Y37 rovere affumicato/smoked oak
Y38 rovere nero/black oak
Y40 frassino argilla/clay ash

X01 rame/copper
X02 ottone/brass
X03 titanio/titanium

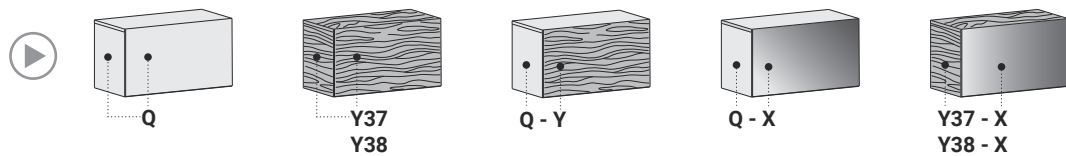

ANTA RIBALTA / FLAP DOOR / PORTE A ABATTANT / Klapptür / Puerta abatible

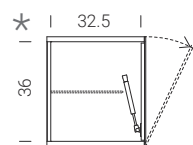
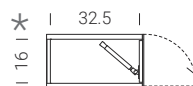
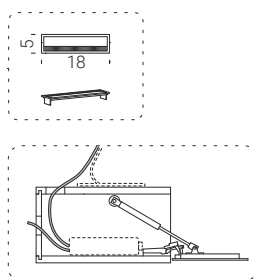
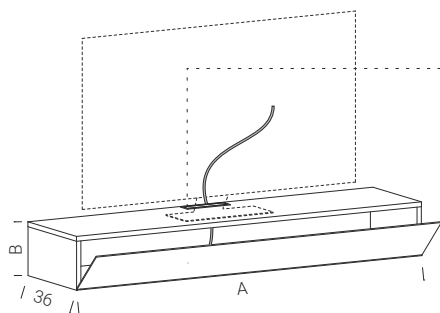
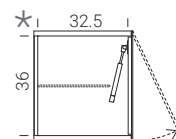
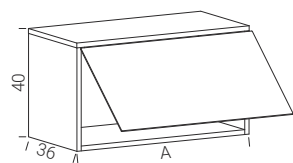
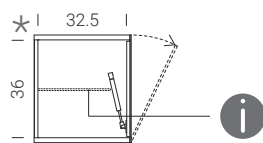
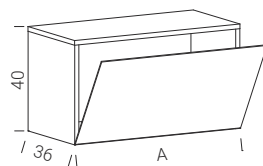
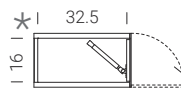
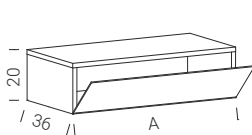

il contenitore prevede il passaggio cavi come da schema
the container incorporates the cable sleeve as shown in the diagram
le conteneur prévoit le passage des câbles comme indiqué sur le schema
Der Turm sieht den Kabeldurchgang laut Schema vor
el contenedor prevé el paso de cables según el esquema

	A x 20	kg max	Q	Y37 Y38	Q-Y	Q-X	Y37-X Y38-X
XCAR0012	73 x 20	25	521	768	602	555	721
XCAR0013	109 x 20	30	625	922	723	666	865
XCAR0014	145 x 20	30	736	1086	851	784	1019

	A x 40	kg max	Q	Y37 Y38	Q-Y	Q-X	Y37-X Y38-X
XCAR0015	36.5 x 40	20	434	641	503	463	601
XCAR0016	73 x 40	25	615	908	712	656	852
XCAR0017	109 x 40	30	737	1089	853	786	1022
XCAR0018	145 x 40	30	846	1249	979	902	1172

	A x 40	kg max	Q	Y37 Y38	Q-Y	Q-X	Y37-X Y38-X
XCAR0019	36.5 x 40	20	434	641	503	463	601
XCAR0020	73 x 40	25	615	908	712	656	852
XCAR0021	109 x 40	30	737	1089	853	786	1022

	A x B	kg max	Q	Y37 Y38	Q-Y	Q-X	Y37-X Y38-X
XCAR0022	73 x 20	25	601	887	695	641	833
XCAR0023	109 x 20	30	685	1011	793	730	948
XCAR0024	145 x 20	30	855	1262	990	912	1184
XCAR0025	73 x 40	25	681	1006	788	726	944
XCAR0026	109 x 40	30	804	1186	930	857	1113
XCAR0027	145 x 40	30	980	1447	1134	1045	1358



dimensioni interne
internal dimensions
dimensions internes
Innenmaße
dimensiones internas



ripiani interni non inclusi
internal shelves not included
étagères internes non incluses
Interne Einlegeböden nicht enthalten
estantes internos no incluidos



Dettaglio anta
Detail of a door
Détail de la porte
Türdetail
Detalle de la puerta

Q laccato/lacquered/laqué
lackiert/lacado

Y essenza/wood/bois
Holz/madera

X laccato metallo/metal lacquered
laqué metal/Metalllackierung
lacado metal

Q05 bianco/white
Q16 seta/silk
Q17 corda/ecru
Q20 ghisa/cast-iron
Q14 antracite/anthracite
Q04 nero/black
Q21 bronzo/bronze

Y36 rovere/oak
Y34 noce/walnut
Y37 rovere affumicato/smoked oak
Y38 rovere nero/black oak
Y40 frassino argilla/clay ash

X01 rame/copper
X02 ottone/brass
X03 titanio/titanium

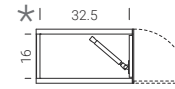
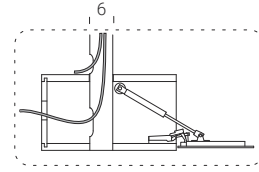
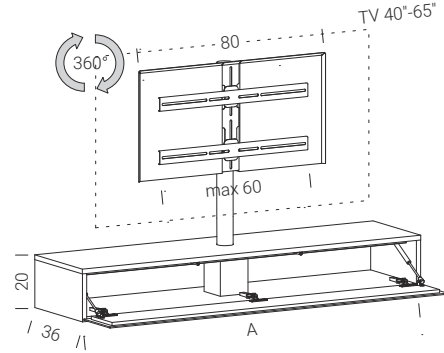
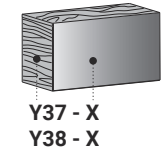
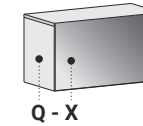
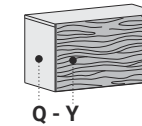
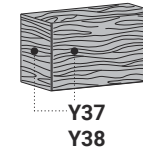
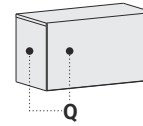

	A x 20	kg max	Q	Y37 Y38	Q-Y	Q-X	Y37-X Y38-X
XCAR0028	109 x 20	30	958	1415	1109	1022	1328
XCAR0029	145 x 20	30	1168	1724	1351	1245	1618



supporto monitor universale per TV da 40 a 65 pollici.
universal monitor support for TV from 40 to 65 inches.
support moniteur universel pour TV de 40 à 65 pouces.
Universal-Monitor-Halter für TV von 40 bis 65 Zoll.
soporte de monitor universal para TV de 40 a 65 pulgadas.

ANTE BATTENTE / LEAF DOOR UNITS / PORTE À BATTANT / FLÜGELTÜR / PUERTA BATIENTE

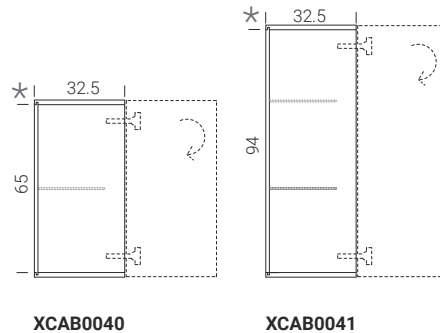
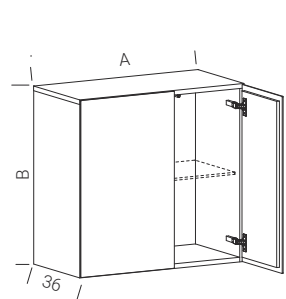
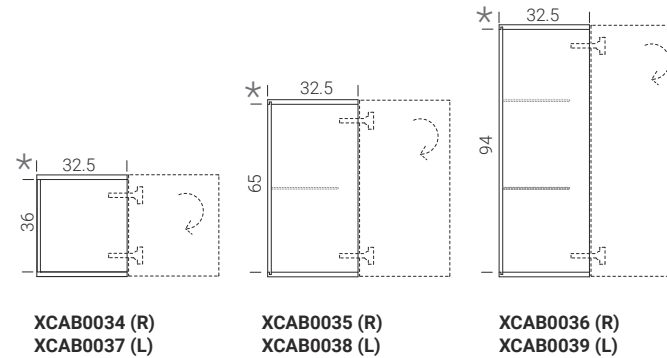
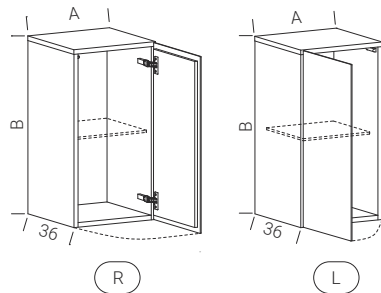

	A x B	kg max	Q	Y37 Y38	Q-Y	Q-X	Y37-X Y38-X
XCAB0034	36.5 x 40	25	390	646	475	430	601
XCAB0035	36.5 x 69	25	487	805	592	536	749
XCAB0036	36.5 x 98	25	504	835	613	555	777
XCAB0037	36.5 x 40	25	390	646	475	430	601
XCAB0038	36.5 x 69	25	487	805	592	536	749
XCAB0039	36.5 x 98	25	504	835	613	555	777

	A x B	kg max	Q	Y37 Y38	Q-Y	Q-X	Y37-X Y38-X
XCAB0040	73 x 69	25	763	1262	928	840	1174
XCAB0041	73 x 98	25	878	1452	1067	966	1351



dimensioni interne
internal dimensions
dimensions internes
Innenmaße
dimensiones internas



ripianti interni non inclusi
internal shelves not included
étagères internes non incluses
Interne Einlegeböden nicht enthalten
estantes internos no incluidos

Q laccato/lacquered/laqué
lackiert/lacado

Y essenza/wood/bois
Holz/madera

X laccato metallo/metal lacquered
laqué metal/Metalllackierung
lacado metal

Q05 bianco/white
Q16 seta/silk
Q17 corda/ecru
Q20 ghisa/cast-iron
Q14 antracite/anthracite
Q04 nero/black
Q21 bronzo/bronze

Y36 rovere/oak
Y34 noce/walnut
Y37 rovere affumicato/smoked oak
Y38 rovere nero/black oak
Y40 frassino argilla/clay ash

X01 rame/copper
X02 ottone/brass
X03 titanio/titanium

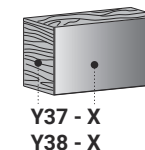
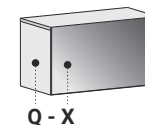
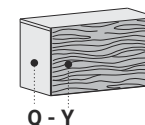
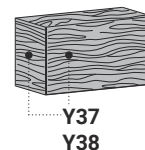
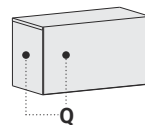

RIPIANI / SHELVES / ÉTAGÈRES / BÖDEN / ESTANTES

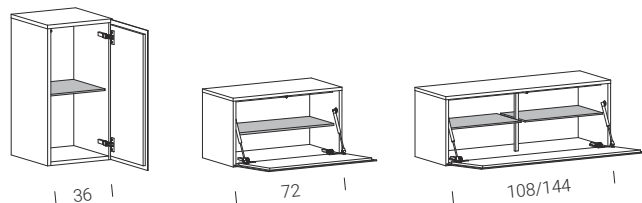

	A x 28	V07
ARIV0035	36 x 28	54
ARIV0036	72.5 x 28	63
ⓘ ARIV0039	108.5 x 28	95
ⓘ ARIV0040	144.5 x 28	110

forature per supporti ripiano da eseguire in opera Ø5 mm
holes for shelf supports to be drilled Ø5 mm
trous pour supports d'étagères à réaliser sur place Ø5 mm
Löcher für Einlegebodenhalter sind mit Ø5 mm vorzunehmen
orificios para soportes de baldas a realizar in situ Ø5 mm

PANNELLO RETRO CONTENITORE / CONTAINER BACK PANEL / PANNEAU ARRIÈRE CONTENEUR / RÜCKSEITENPLATTEN TURM / PANEL POSTERIOR CONTENEDOR

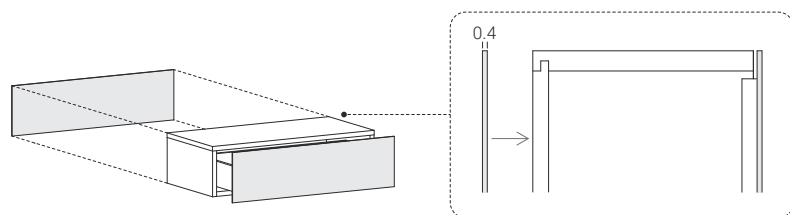

Per le composizioni bifacciali è disponibile un frontale del contenitore da utilizzare come pannello retro. **Prezzo su richiesta.**
For double-sided compositions, a container front panel is available that can be used as a back panel. **Price on request.**
Pour les compositions double face, une face avant du conteneur est disponible pour servir de panneau arrière. **Prix sur demande.**
Für die beidseitigen Kombinationen ist eine als Rückseitenplatte verwendbare Vorderseite des Turms verfügbar. **Preis auf Anfrage.**
Para las composiciones de doble cara está disponible un frontal del contenedor para usar como panel posterior. **Precio bajo petición.**

CASSETTIERE / DRAWERS UNITS / KITS DE TIROIRS / SCHUBLADENELEMENTE / CAJONERAS

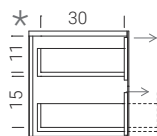
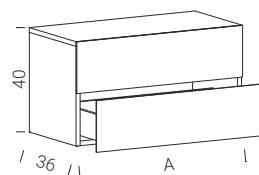
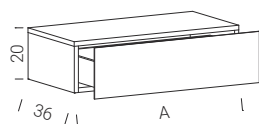

	A x 20	kg max	Q	Y37 Y38	Q-Y	Q-X	Y37-X Y38-X
XCSS0016	36.5 x 20	25	353	510	401	375	484
XCSS0017	73 x 20	25	460	664	521	488	631
XCSS0018	109 x 20	25	569	822	645	604	781

	A x 40	kg max	Q	Y37 Y38	Q-Y	Q-X	Y37-X Y38-X
XCSS0019	36.5 x 40	25	516	745	585	547	707
XCSS0020	73 x 40	25	670	964	760	711	918
XCSS0021	109 x 40	25	815	1176	924	868	1117

*

dimensioni interne
internal dimensions
dimensions internes
Innenmaße
dimensiones internas

ⓘ

il codice prevede una coppia di ripiani
the code includes two shelves
le code prévoit deux étagères
Artikelnummer sieht ein Einlegebodenpaar
el código prevé un par de estantes

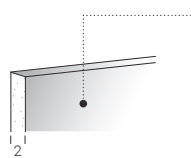

Q MDF laccato/lacquered MDF/MDF laqué
lackiert MDF/MDF lacado

- Q05** bianco/white
- Q16** seta/silk
- Q17** corda/ecru
- Q20** ghisa/cast-iron
- Q14** antracite/anthracite
- Q04** nero/black
- Q21** bronzo/bronze

Y MDF legno/MDF wood/MDF bois
MDF Holz/DM madera

- Y36** rovere/oak
- Y34** noce/walnut
- Y37** rovere affumicato/smoked oak
- Y38** rovere nero/black oak
- Y40** frassino argilla/clay ash

plastica/plastic/plastique
Kunststoff/plástico

- C04** silver/silver
- C08** nero/black

PASSACAVO / CABLE TIDY / PASSE-CÂBLES / KABELDURCHFÜHRUNG / PASACABLES

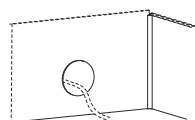

La foratura è da eseguire in opera
holes are to be made during installation
le perçage est à effectuer lors du montage
Die Bohrung ist bei der Montage anzubringen
el perforado debe llevarse a cabo durante la instalación

	C04
	C08
XACC0014	8

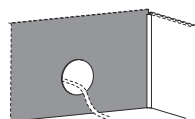

passacavo con servizio di foratura
cable duct with perforation service
passe-câbles avec service de perçage
Kabeldurchführung mit Bohrmöglichkeit
pasacable con servicio de perforado

	C04
	C08
XACC0028	60

**PANNELLO DI COMPENSAZIONE TRA CONTENITORI / BLANKING PANEL BETWEEN CONTAINERS
PANNEAU DE COMPENSATION ENTRE CONTENEURS / AUSGLEICHSPLATTE ZWISCHEN TÜRME
PANEL DE COMPENSACIÓN ENTRE CONTENEDORES**

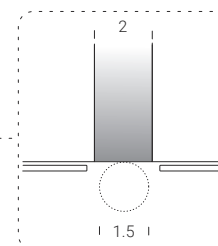
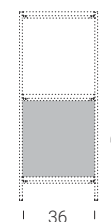
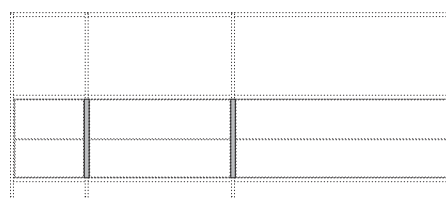
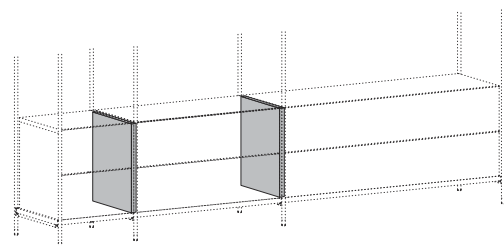

	B x 36	Q	Y37 Y38
XFIL0006	20 x 36	60	69
XFIL0006	40 x 36	80	92
XFIL0006	69 x 36	90	103
XFIL0006	98 x 36	100	115

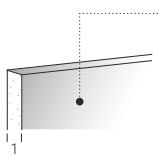

Q MDF laccato/lacquered MDF/MDF laqué
lackiert MDF/MDF lacado

- Q05** bianco/white
- Q16** seta/silk
- Q17** corda/ecru
- Q20** ghisa/cast-iron
- Q14** antracite/anthracite
- Q04** nero/black
- Q21** bronzo/bronze

Y MDF legno/MDF wood/MDF bois
MDF Holz/DM madera

- Y36** rovere/oak
- Y34** noce/walnut
- Y37** rovere affumicato/smoked oak
- Y38** rovere nero/black oak
- Y40** frassino argilla/clay ash

SCHIENE / BACKS / DOS / RÜCKWÄNDE / TRASERAS

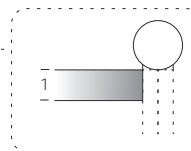
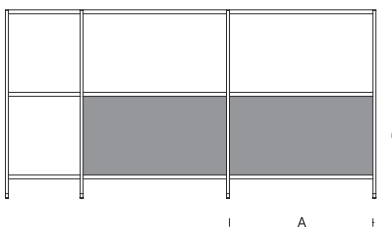
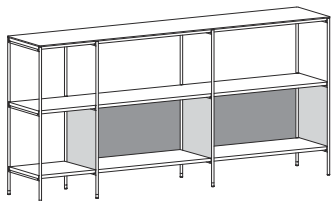

	A x B	Q	Y
XSIL0009	36.5 x 20	92	103
XSIL0009	73 x 20	114	136
XSIL0009	109 x 20	141	174
XSIL0009	145 x 20	162	207
XSIL0009	36.5 x 40	118	140
XSIL0009	73 x 40	151	194
XSIL0009	109 x 40	191	256
XSIL0009	145 x 40	224	311
XSIL0009	36.5 x 82	184	228
XSIL0009	73 x 82	240	328
XSIL0009	109 x 82	307	440
XSIL0009	145 x 82	363	540
XSIL0009	109 x 124	411	608
XSIL0009	145 x 124	489	751

COPPIA FIANCHI BICOLORE / PAIR OF TWO-TONE SIDES / PAIRE DE CÔTÉS BICOLORE / EIN PAAR SEITENWÄNDE ZWEIFARBIG / PAR LATERALES BICOLOR

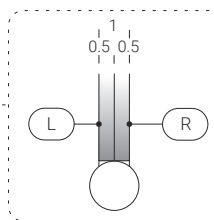
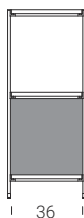
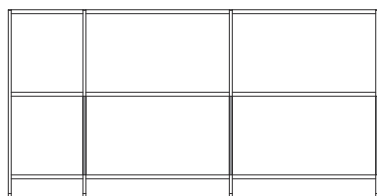
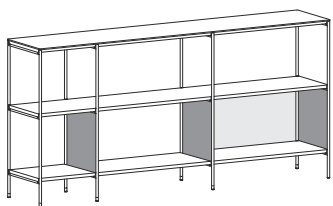

	B x 36	L/R Q/Q	L/R Q/Y	L/R Y/Y
XFIL0005	20 x 36	90	98	104
XFIL0005	40 x 36	122	133	140
XFIL0005	82 x 36	179	195	206
XFIL0005	124 x 36	196	213	226

i 2 pannelli L/R possono avere colori diversi
the two panels L/R can be in different colours
les 2 panneaux L/R peuvent avoir des couleurs différentes
Die zwei Platten L/R können unterschiedliche Farben haben
los dos paneles L/R pueden ser de distinto color



le schiene sono utilizzabili solamente con la coppia di fianchi
the backrests can be used only with the two sides
les dossiers ne peuvent être utilisés qu'avec la paire de panneaux latéraux
Die Rückseiten sind nur mit dem Seitenteilpaar verwendbar
las traseras solo se pueden utilizar con los dos lados



disponibili riduzioni a misura
custom reductions available
Verkürzungen auf Maß erhältlich
réductions sur mesure disponibles
disponibles reducciones a medida



XRID0005
+30 €

XRID0005
+30 €



XRID0007
+30 €

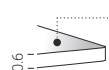

- L HPL POLARIS®**
L03 bianco/white
L10 grigio chiaro/light grey
L11 grigio scuro/dark grey
- HPL FENIX®**
L08 grigio Londra/London grey
L06 nero/black

- Q HPL laccato/lacquered HPL/HPL laqué
lackiert HPL/HPL lacado**
Q16 seta/silk
Q17 corda/ecru
Q20 ghisa/cast-iron
Q14 antracite/anthracite
Q21 bronzo/bronze

- S ceramica/ceramic/c eramique
Keramik/cer mico**
S05 antracite/anthracite
S06 nero/black
S07 porfido/porfido
S08 cardoso/cardoso

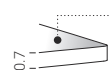

- Y HPL+ legno/wood/bois/Holz/madera**
Y36 rovere/oak
Y34 noce/walnut
Y37 rovere affumicato/smoked oak
Y38 rovere nero/black oak
Y40 frassino argilla/clay ash
- N HPL+ ecotouch**
N01 sabbia/sand
N02 basalto/basalt

- C HPL+ metallo/metal/m tal/Metall/metal**
C31 ottone/brass
C32 ottone brunito/burnished brass
C35 inox/inox
C36 inox scuro/dark inox
- D HPL+ cemento/concrete/ciment
zement/cemento**
D01 bianco calce/lime white
D02 grigio Portland/Portland grey
D03 nero/black

TOP / TOP / PLATEAU / PLATTE / PLANO

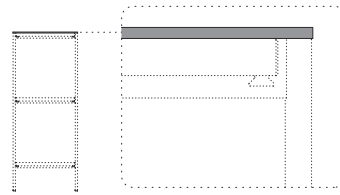
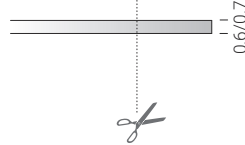
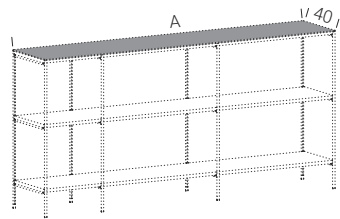

	A x 40	L03 L06	L08 L10 L11	Q	S	Y	N	C	D
XRIP0010	114 x 40	230	261	210	294	311	237	617	273
XRIP0010	150.5 x 40	280	318	255	359	379	289	752	333
XRIP0010	186.5 x 40	330	374	300	422	446	340	885	391
XRIP0010	225 x 40	396	450	361	508	537	409	1064	471
XRIP0010	261 x 40	445	506	406	571	603	460	1196	529
XRIP0010	297 x 40	495	562	451	633	670	511	1328	587
XRIP0010	333 x 40	546	621	498	-	740	564	-	-

Si consiglia l'utilizzo del top che completa la composizione e copre la parte sommitale dei profili
 We recommend the use of the top that completes the composition and covers the top part of the profiles
 Nous conseillons l'utilisation du plateau qui compl te la composition et couvre la partie au sommet des profils
 Wir empfehlen Ihnen die Verwendung eines Tops, da es einerseits die Komposition vervollst ndigt und andererseits die Profil-Oberseite abdeckt
 Recomendamos el uso de la parte superior que completa la composici n y cubre la parte superior de los perfiles

KIT PER APPOGGIO MARMO / MARBLE SHELF SUPPORT KIT / KIT DE SUPPORT D' TAG RE EN MARBRE ST TZSATZ F R MARMORREGALE / KIT DE SOPORTE DE ESTANTER A DE M RMOL

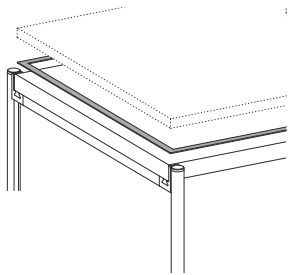

Si consiglia di reperire il top in marmo localmente e di utilizzare il kit di appoggio XACC0033. Il kit   composto da un materassino in neoprene adesivo che pu  essere tagliato e applicato in opera.
 We recommend that the marble top be obtained locally and that the XACC0033 support kit be used. The kit consists of an adhesive neoprene mat that can be cut and applied on site.
 Nous vous conseillons de vous procurer le plateau en marbre sur place et d'utiliser le kit de support XACC0033. Le kit se compose d'un petit matelas en n opr ne adh sif qui peut  tre d coup  et appliqu  sur place.
 Es empfiehlt sich, die Marmorplatte (Top) vor Ort, unter Verwendung des Befestigungssets XACC0033, aufzubringen. Das Set beinhaltet eine selbstklebende Neoprenmatte, die bei Bedarf zugeschnitten und aufgeklebt werden kann.
 Recomendamos obtener la encimera de m rmol en una tienda local y usar el kit de soporte XACC0033. El kit consiste en una estera adhesiva de neopreno que se puede cortar y aplicar en el sitio.

	A x 40	
XACC0033	114 x 40	24
XACC0033	150.5 x 40	28
XACC0033	186.5 x 40	30
XACC0033	225 x 40	45
XACC0033	261 x 40	52
XACC0033	297 x 40	58
XACC0033	333 x 40	62

DIMA DI INSTALLAZIONE PER COMPOSIZIONI XY / INSTALLATION TEMPLATE FOR XY COMPOSITIONS GABARIT D'INSTALLATION POUR COMPOSITIONS XY / INSTALLATIONSSCHABLONE F R KOMBINATIONEN XY PLANTILLA DE INSTALACI N PARA COMPOSICIONES XY



XACC0026	60
-----------------	----



disponibili riduzioni a misura
 custom reductions available
 Verk rzungen auf Ma  erh ltlich
 r ductions sur mesure disponibles
 disponibles reducciones a medida

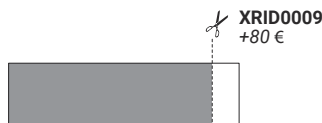

SYSTEM

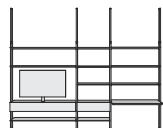

IL SISTEMA BREVETTATO EXTENDO È FORMATO DA DUE PROFILI IN ALLUMINIO ESTENSIBILI, ADATTABILI ALLE DIVERSE ALTEZZE DEGLI AMBIENTI. AGENDO SULLA LEVA A SCOMPARSA, I PROFILI SI BLOCCANO ALL'ALTEZZA DESIDERATA E SI COMPRIMONO TRA PAVIMENTO E SOFFITTO, SENZA L'UTILIZZO DI ALCUN UTENSILE O PRE-FISSAGGIO.

The patented extendo system consists of two extendable aluminium profiles that can be adapted to environments of various heights. Using the foldaway lever, the profiles can be blocked at the desired height and compressed between floor and ceiling, without having to use any kind of pre-fixing tool.

Le système breveté extendo est constitué de deux profilés extensibles en aluminium pouvant être adaptés aux différentes hauteurs des milieux. En agissant sur le levier escamotable, les profilés se verrouillent à la hauteur souhaitée et se compriment entre plancher et plafond, sans utiliser aucun outil ou préfixation.

Das patentierte System extendo besteht aus zwei ausziehbaren Aluminium-Profilen, die an unterschiedliche Raumhöhen angepasst werden können. Durch einen versenkbaren Hebel werden die Profile auf der gewünschten Höhe blockiert und zwischen Fußboden und Zimmerdecke ohne Werkzeug oder Vor-Befestigung komprimiert eingesetzt.

El sistema patentado extendo está formado por dos perfiles de aluminio extensibles, adaptables a las distintas alturas de los ambientes. Actuando sobre la palanca escondida, los perfiles se bloquean a la altura deseada y se comprimen entre el suelo y el techo, sin que sea necesario utilizar ninguna herramienta o fijación previa.

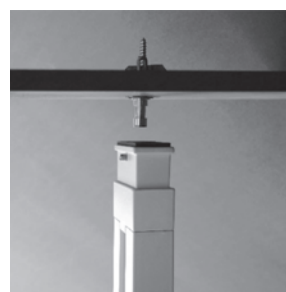
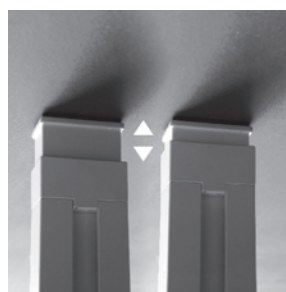
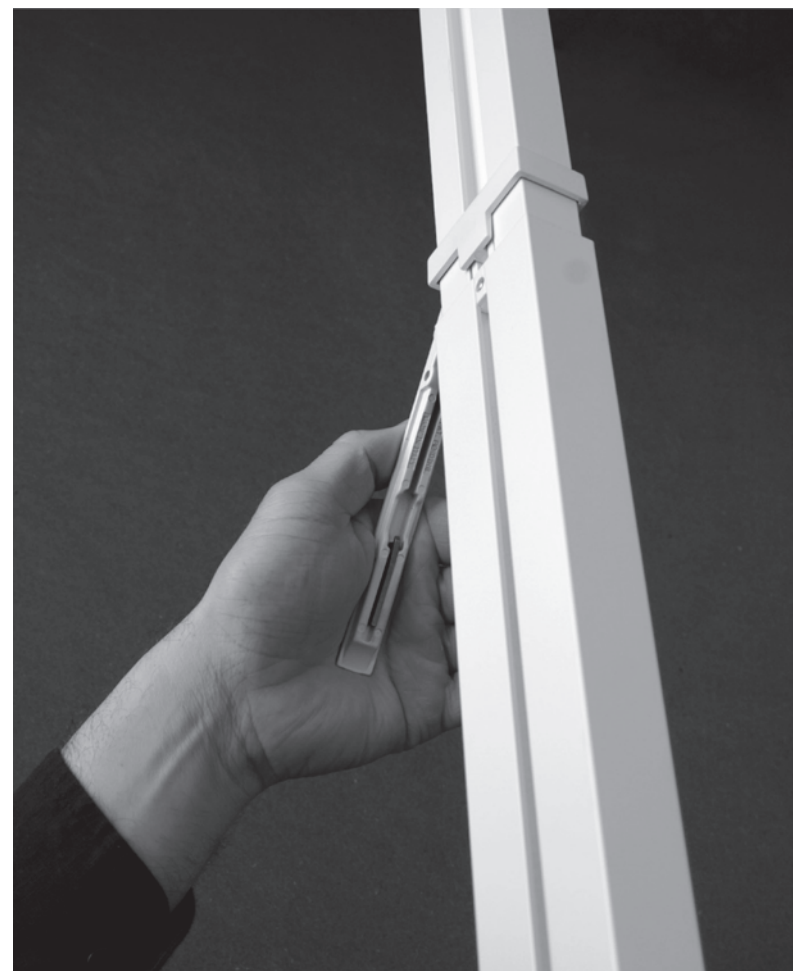



PRODUCT CONCEPT

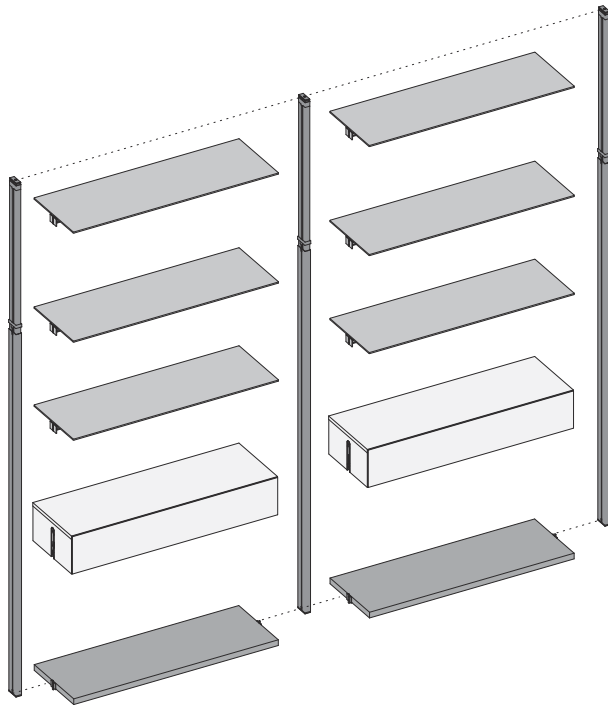

L modules
36 - 72 - 108 - 144

H modules
210 / 400

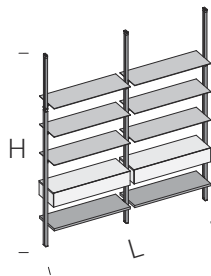

Ripiani e contenitori hanno libera posizione in altezza, (al centimetro).

Shelves and containers can be positioned at any height (to the centimetre).

Les étagères et les conteneurs peuvent être positionnés librement en hauteur (au centimètre près).

Einlegeböden und Behälter sind in der Höhe frei einsetzbar (auf den Zentimeter).

Los estantes y contenedores tienen una altura libre (al centimetro).

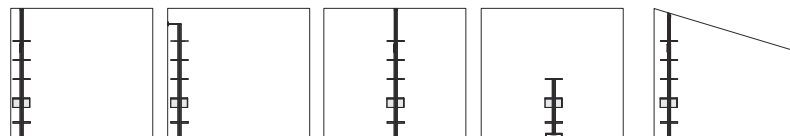

Pavimento / soffitto
Floor / ceiling
Sol / plafond
Boden / Decke
Suelo / techo

Pavimento / parete
Floor / wall
Sol / mur
Boden / Wand
Suelo / pared

Bifacciale
Double-sided
Sol / mur
Zweiseitig
Doble cara

Pavimento / bifacciale
Floor / Double-sided
Sol / Double face
Boden / Zweiseitig
Suelo / Doble cara

Soffitto inclinato
Sloping ceiling
Plafond incliné
Schräge Decke
Techo inclinado



Sistema brevettato Patented system Système breveté Patentiertes system Sistema patentado

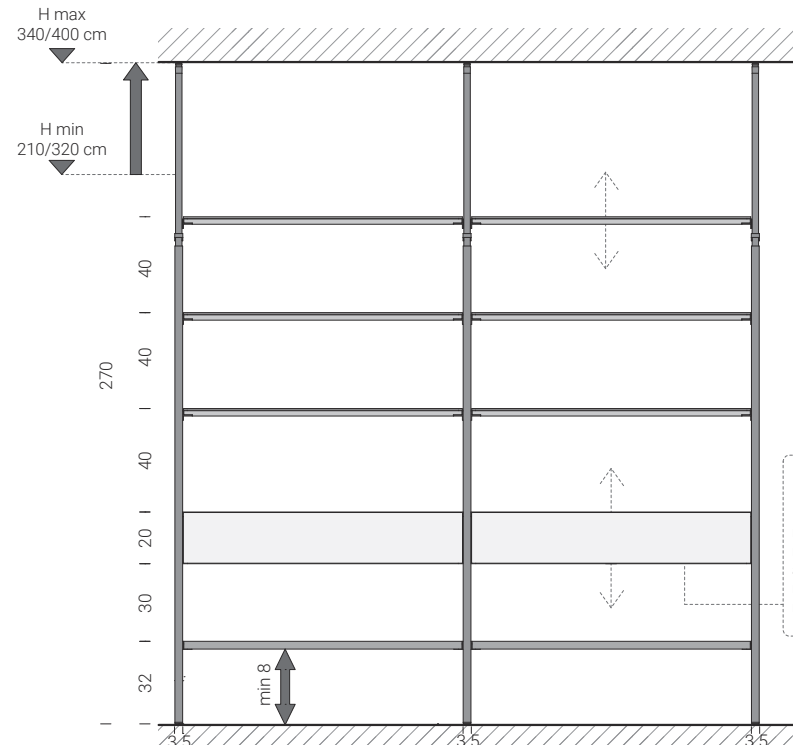

non riducibili
non-reducible items
aucune réduction possible
nicht verkürzbar
no reducibles

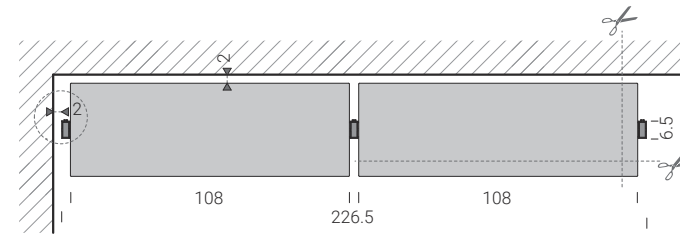

distanza minima dalle pareti 2 cm
minimum distance from walls 2 cm
distance minimale des murs 2 cm
Mindestabstand von Wänden 2 cm
distancia mínima de las paredes 2 cm



Riduzioni a misura disponibili su profili verticali, ripiani e pannelli rivestimento.
Measurement reductions available on vertical profiles, shelves and panels.
Réductions sur mesure possibles sur les profilés verticaux, les étagères et les panneaux de revêtement.
Verkürzung nach Kundenwunsch auf vertikalen Profilen, Einlegeböden und Verkleidungsplatten.
Las reducciones de tamaño son posibles en los perfiles verticales, las repisas y los paneles de revestimiento.



Passacavi disponibili su pannelli rivestimento e contenitori.
Cable sleeves available on panels and containers.
Passe-câbles disponibles sur les panneaux de revêtement et les conteneurs.
Kabeldurchgänge auf Verkleidungsplatten und ehälter verfügbar.
Pasacables disponibles en los paneles de revestimiento y en los contenedores.



Profilo telescopico brevettato
Patented telescopic profile
Profilé télescopique breveté
Patentiertes teleskopisches Profil
Perfil telescópico patentado

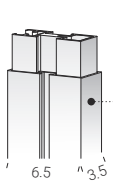

C alluminio verniciato/painted aluminium/aluminium peint
lackierter Aluminium/aluminio pintado

- C12** bianco/white
- C21** seta/silk
- C30** ghisa/cast-iron
- C08** nero/black
- C29** bronzo/bronze

**PROFILO ESTENSIBILE EXTENDO / EXTENDO EXTENDABLE PROFILE / PROFILÉ EXTENSIBLE EXTENDO
AUSZIEHBARE PROFILE EXTENDO / BORDE EXTENSIBLES EXTENDO**

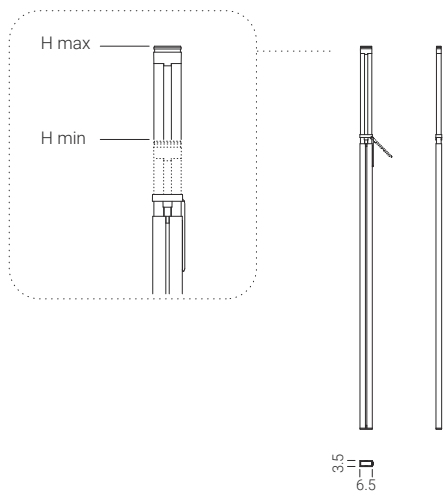

	H min - H max (cm)	C
EXTE0001	210 - 340	280
EXTE0005	320 - 400	320

**ADATTATORE PER SOFFITTO INCLINATO / SLOPING CEILING ADAPTER
ADAPTEUR POUR PLAFOND INCLINÉ / ADAPTER FÜR DACHSCHRÄGEN
ADAPTADOR PARA TECHO INCLINADO**

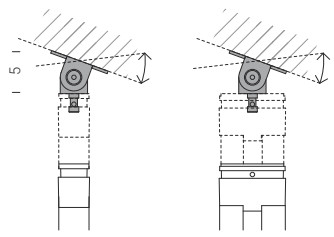

	C
EADA0001	30

**ADATTATORE A PARETE / WALL-MOUNT ADAPTOR / ADAPTATEUR MURAL
WANDADAPTER / ADAPTADOR DE PARED**

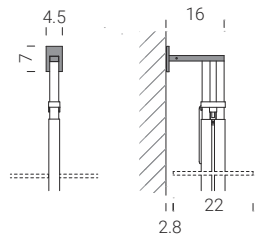

	C
EADA0026	60

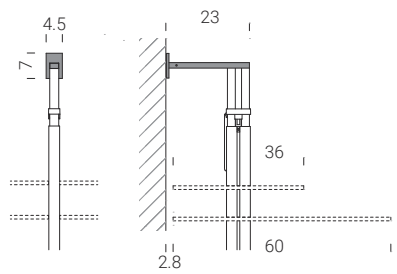

	C
EADA0014	62

**ADATTATORE PER SOFFITTO IN CARTONGESSO / PLASTER BOARD CEILING ADAPTER /
ADAPTEUR POUR PLAFOND EN PLACOPLÂTRE / ADAPTER FÜR DECKEN AUS GIPSKARTON
ADAPTADOR PARA TECHO DE CARTÓN YESO**

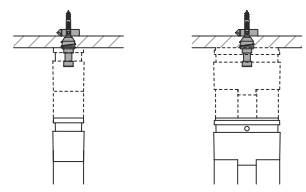

EADA0002	11
-----------------	----

i solo per cartongesso in lastre/only for plaster-board panelled ceiling/seulement pour plafonds en plaque de placo-plâtre
nur für Decken aus Gipskartonplatten/sólo para techo de cartón yeso de lámina

disponibili riduzioni a misura
custom reductions available
Verkürzungen auf Maß erhältlich
réductions sur mesure disponibles
disponibles reducciones a medida

ERID0001
+60 €

60 kg max

Il carico massimo sul profilo superiore è 60 kg
The maximum load on the upper profile is 60 kg
La charge maximale sur le profilé supérieur est de 60 kg
Das obere Profil kann maximal mit 60 kg belastet werden
La carga maxima en el perfil superior es de 60 kg

⚠ Sconsigliamo l'utilizzo degli adattatori in composizioni con asta telescopica extendo singola.
We advise you against using adaptors in compositions with a single extendo telescopic bar.
Nous déconseillons l'utilisation d'adaptateurs dans des compositions avec une seule barre télescopique extendo.
Wir nicht empfehlen, die Adapter in Zusammensetzungen mit einem einzigen Teleskopstange extendo verwenden.
No se recomienda utilizar los adaptadores en composiciones con una sola barra telescópica extendo.

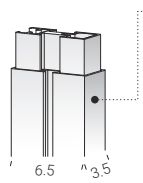

C alluminio verniciato/painted aluminium/aluminium peint
lackierter Aluminium/aluminio pintado

- C12** bianco/white
- C21** seta/silk
- C30** ghisa/cast-iron
- C08** nero/black
- C29** bronzo/bronze

EXTENDO NON TELESCOPICO / EXTENDO NON-TELESCOPIC / EXTENDO NON TÉLESCOPIQUE / EXTENDO NICHT TELESKOP / EXTENDO NO TELESCÓPICO

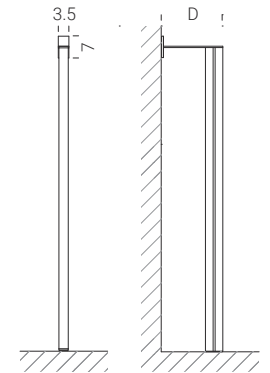
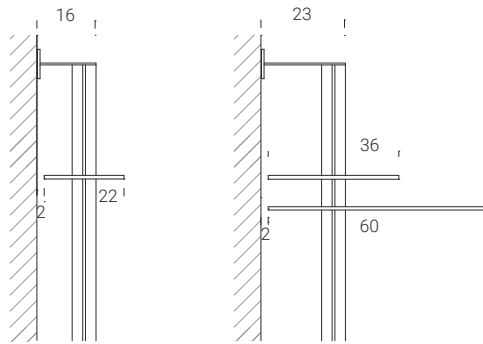

	H x D	C
EXTE0011	160 x 16	168
EXTE0012	240 x 16	198
EXTE0013	290 x 16	218
EXTE0017	160 x 23	172
EXTE0018	240 x 23	202
EXTE0019	290 x 23	222

**PROFILO EXTENDO FREE-STANDING / EXTENDO FREE-STANDING PROFILE / PROFILÉ EXTENDO FREE-STANDING
EXTENDO-PROFIL FREE-STANDING / PERFIL EXTENDO FREE-STANDING**

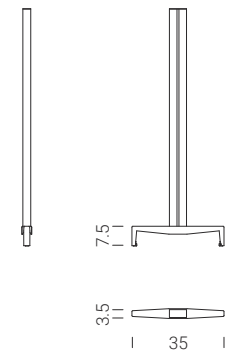

	H	C
EXTE0008	60	175
EXTE0009	90	185
EXTE0010	160	220



disponibili riduzioni a misura
custom reductions available
Verkürzungen auf Maß erhältlich
réductions sur mesure disponibles
disponibles reducciones a medida

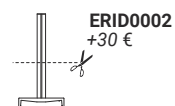
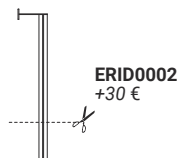

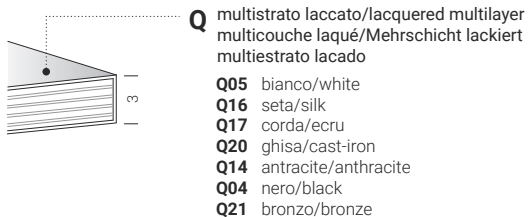

RIPIANI IN MULTISTRATO / MULTILAYER SHELVES / ÉTAGÈRES EN MULTICOUCHE BÖDEN AUS MEHRSCICHT / ESTANTES DE MULTIESTRATO

	A x 36 x 3	kg/ml	Q
PRIP0017	36 x 36 x 3	30	124
PRIP0009	72 x 36 x 3	30	169
PRIP0010	108 x 36 x 3	30	208
PRIP0019	144 x 36 x 3	18	251

	A x 36 x 3	kg/ml	Q
PRIP0021	108 x 36 x 3	30	208
PRIP0022	108 x 36 x 3	30	208

	A x 36 x 3	C	kg/ml	Q
PRIP0013	112 x 36 x 3	72	30	230
PRIP0014	148 x 36 x 3	108	30	285
PRIP0032	184 x 36 x 3	144	30	298

	A x 36 x 3	C	kg/ml	Q
PRIP0001	151 x 36 x 3	72	30	296
PRIP0002	187 x 36 x 3	108	30	345
PRIP0020	223 x 36 x 3	144	30	365

TOP SCRIVANIA IN MULTISTRATO / MULTILAYER DESKTOP PLATEAU DE BUREAU EN MULTICOUCHE / SCHREIBTISCH AUS MEHRSCICHT ESCRITORIO DE MULTIESTRATO

	A x 60 x 3	kg/ml	Q
PRIP0012	108 x 60 x 3	30	299
PRIP0030	144 x 60 x 3	30	385

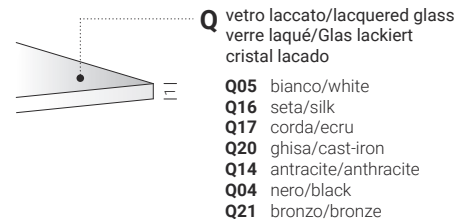

vetro trasparente/transparent glass
verre transparent/Glas transparent
cristal transparente

V06 fumè/smoked

RIPIANI IN VETRO / GLASS SHELVES / ÉTAGÈRES EN VERRE BÖDEN AUS GLAS / ESTANTES DE CRISTAL

	A x 22 x 1	kg/ml	V06	Q
ARIV0012	36 x 22 x 1	25	135	144
ARIV0013	72 x 22 x 1	25	150	160
ARIV0014	108 x 22 x 1	25	164	195

	A x 36 x 1	kg/ml	V06	Q
ARIV0015	36 x 36 x 1	25	152	160
ARIV0003	72 x 36 x 1	25	157	176
ARIV0004	108 x 36 x 1	25	183	215

	A x 36 x 1	kg/ml	V06	Q
ARIV0019	108 x 36 x 1	25	338	372
ARIV0020	108 x 36 x 1	25	338	372

	A x 36 x 1	C	kg/ml	V06	Q
ARIV0007	112 x 36 x 1	72	25	215	237
ARIV0008	148 x 36 x 1	108	25	241	293

	A x 36 x 1	C	kg/ml	V06	Q
ARIV0005	151 x 36 x 1	72	25	260	303
ARIV0006	187 x 36 x 1	108	25	310	351



disponibili riduzioni a misura (prezzo per 1 taglio)
custom reductions available (price for 1 cut)
réductions sur mesure disponibles (prix pour 1 coupe)
Verkürzungen auf Maß erhältlich (Preis für 1 Schnitt)
disponibles reducciones a medida (precio por 1 corte)

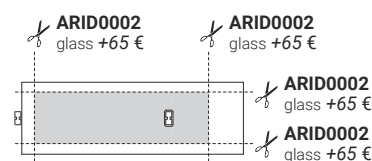
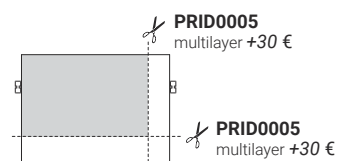
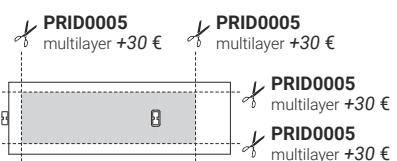

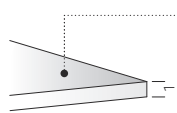

Q vetro laccato/lacquered glass
verre laqué/Glas lackiert
cristal lacado

- Q05** bianco/white
- Q16** seta/silk
- Q17** corda/ecru
- Q20** ghisa/cast-iron
- Q14** antracite/anthracite
- Q04** nero/black
- Q21** bronzo/bronze

vetro trasparente/transparent glass
verre transparent/Glas transparent
cristal transparente

V06 fumè/smoked

RIPIANI IN VETRO CON RINFORZO / GLASS SHELVES WITH REINFORCEMENT
ÉTAGÈRES EN VERRE AVEC RENFORT / BÖDEN AUS GLAS VERSTÄRKT
ESTANTES DE CRISTAL CON REFUERZO

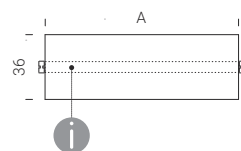

	A x 36 x 1	kg/ml	V06	Q
ARIV0028	36 x 36 x 1	35	184	192
ARIV0029	72 x 36 x 1	35	199	217
ARIV0030	108 x 36 x 1	35	239	271
ARIV0027	144 x 36 x 1	35	331	373

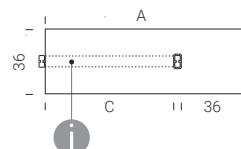

	A x 36 x 1	C	kg/ml	V06	Q
ARIV0031	112 x 36 x 1	72	35	271	292
ARIV0032	148 x 36 x 1	108	35	292	342
ARIV0038	184 x 36 x 1	144	35	343	388

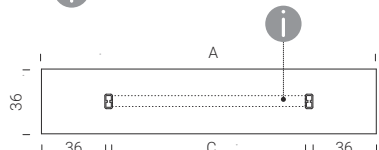

	A x 36 x 1	C	kg/ml	V06	Q
ARIV0033	151 x 36 x 1	72	35	300	355
ARIV0034	187 x 36 x 1	108	35	368	399
ARIV0041	223 x 36 x 1	144	35	421	469

TOP SCRIVANIA IN VETRO / GLASS DESKTOP / PLATEAU DE BUREAU EN VERRE
SCHREIBTISCHPLATTE AUS GLAS / PLANO DE TRABAJO DE CRISTAL

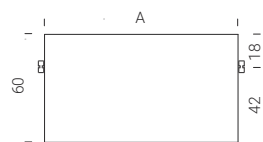

	A x 60 x 1	kg/ml	V06
ARIV0009	108 x 60 x 1	25	362

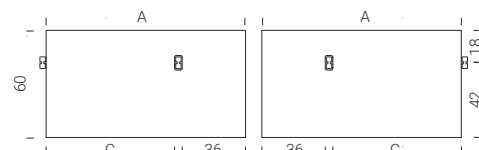

	A x 60 x 1	C	kg/ml	V06
ARIV0010	148 x 60 x 1	108	25	672
ARIV0011	148 x 60 x 1	108	25	672

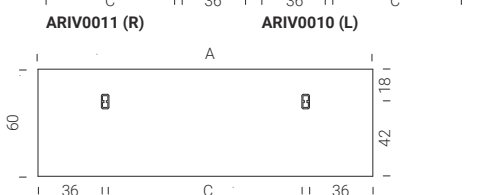

	A x 60 x 1	C	kg/ml	V06
ARIV0018	151 x 60 x 1	72	25	748
ARIV0016	187 x 60 x 1	108	25	883



Il rinforzo sottostante il ripiano è della stessa finitura del profilo extendo.
The reinforcement under the top has the same finish as the extendo profile.
Le renfort sous l'étagère est dans la même finition que le profilé extendo.
Die Verstärkung unter dem Regal wird wie das Profil Extendo vollendet.
El refuerzo bajo el estante es del mismo acabado que el perfil extendo.



disponibili riduzioni a misura (prezzo per 1 taglio)
custom reductions available (price for 1 cut)
réductions sur mesure disponibles (prix pour 1 coupe)
Verkürzungen auf Maß erhältlich (Preis für 1 Schnitt)
disponibles reducciones a medida (precio por 1 corte)

RIPIANO IN VETRO SUPERIORE / UPPER GLASS SHELF / ÉTAGÈRE SUPÉRIEURE EN VERRE
BODEN AUS GLAS OBEN / ESTANTE DE CRISTAL SUPERIOR

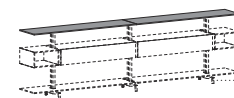

EXTE0008
EXTE0009
EXTE0010

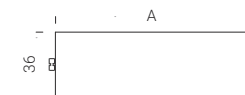

	A x 36 x 1	kg/ml	V06	Q
ARIV0021	72 x 36 x 1	25	135	178
ARIV0022	108 x 36 x 1	25	174	217

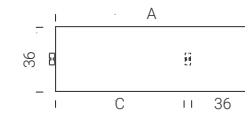

	A x 36 x 1	C	kg/ml	V06	Q
ARIV0023	112 x 36 x 1	72	25	193	237
ARIV0024	148 x 36 x 1	108	25	248	301

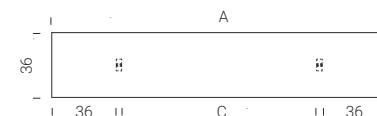

	A x 36 x 1	C	kg/ml	V06	Q
ARIV0025	151 x 36 x 1	72	25	264	312
ARIV0026	187 x 36 x 1	108	25	323	366

CONTENITORE APERTO IN VETRO / GLASS OPEN CABINET / COMPARTIMENT OUVERT EN VERRE
OFFENER BEHÄLTER AUS GLAS / MÓDULO ABIERTO DE CRISTAL

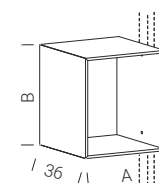

	A x B	kg max	V06	Q
ACAP0004	36 x 20	12	378	408
ACAP0002	36 x 40	12	421	488

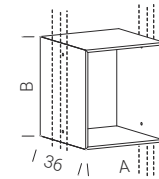

	A x B	kg max	V06	Q
ACAP0005	36 x 20	12	384	528
ACAP0003	36 x 40	12	466	546

Non possono essere installati sul profilo superiore.
They cannot be installed on the upper profile.
Ne peuvent pas être installés sur le profilé supérieur.
Können nicht auf obere Profile angebracht werden.
No se pueden instalar en el perfil superior.

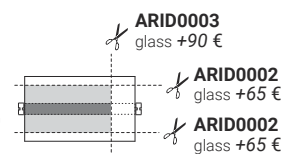

ARID0003
glass +90 €

ARID0002
glass +65 €

ARID0002
glass +65 €

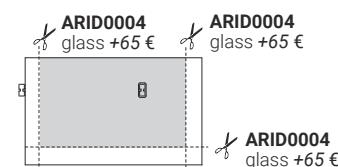

ARID0004
glass +65 €

ARID0004
glass +65 €

ARID0004
glass +65 €

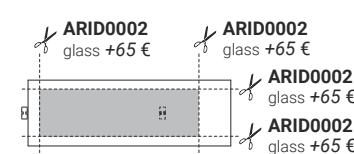

ARID0002
glass +65 €

ARID0002
glass +65 €

ARID0002
glass +65 €

ARID0002
glass +65 €

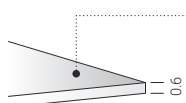
**L** HPL

HPL POLARIS®

L03 bianco/white**L10** grigio chiaro/light grey**L11** grigio scuro/dark grey

HPL FENIX®

L08 grigio Londra/London grey**L06** nero/black**Q** HPL laccato/lacquered HPL/HPL laqué
lackiert HPL/HPL lacado**Q05** bianco/white**Q16** seta/silk**Q17** corda/ecru**Q20** ghisa/cast-iron**Q14** antracite/anthracite**Q04** nero/black**Q21** bronzo/bronze**Y** HPL+ legno/wood/bois
Holz/madera**Y36** rovere/oak**Y34** noce/walnut**Y37** rovere affumicato/smoked oak**Y38** rovere nero/black oak**Y40** frassino argilla/clay ash

RIPIANI IN HPL / HPL SHELVES / ÉTAGÈRES EN HPL / BÖDEN AUS HPL / ESTANTES DE HPL

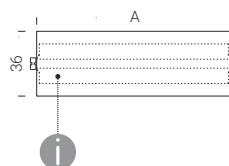

	A x 36 x 0,6	kg/ml	Q	L03 L06	L08 L10 L11	Y
PRIP0024	36 x 36 x 0,6	35	171	181	195	185
PRIP0025	72 x 36 x 0,6	35	240	253	273	259
PRIP0026	108 x 36 x 0,6	35	305	322	348	330
PRIP0027	144 x 36 x 0,6	35	375	396	427	405

TOP SCRIVANIA IN HPL / HPL DESKTOP / PLATEAU DE BUREAU EN HPL / SCHREIBTISCH AUS HPL / ESCRITORIO DE HPL

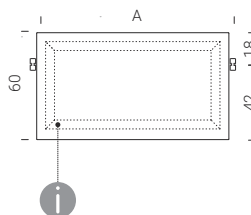

	A x 60 x 0,6	kg/ml	Q	L03 L06	L08 L10 L11	Y
PRIP0031	72 x 60 x 0,6	35	422	445	480	455
PRIP0028	108 x 60 x 0,6	35	515	543	586	556
PRIP0029	144 x 60 x 0,6	35	604	637	687	651

non disponibili nelle finiture laccate **Q05/Q04**
 not available with lacquered finishes **Q05/Q04**
 non disponible en finitions laquées **Q05/Q04**
 Für Lackvollendungen nicht verfügbar **Q05/Q04**
 no disponible en acabados lacados **Q05/Q04**



disponibili riduzioni a misura (prezzo per 1 taglio)
 custom reductions available (price for 1 cut)
 réductions sur mesure disponibles (prix pour 1 coupe)
 Verkürzungen auf Maß erhältlich (Preis für 1 Schnitt)
 disponibles reducciones a medida (precio por 1 corte)

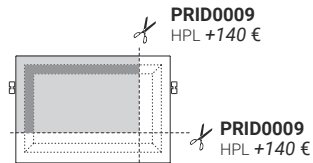
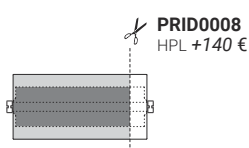

Il rinforzo sottostante il ripiano è della stessa finitura del profilo extendo.
 The reinforcement under the top has the same finish as the extendo profile.
 Le renfort sous l'étagère est dans la même finition que le profilé extendo.
 Die Verstärkung unter dem Regal wird wie das Profil Extendo vollendet.
 El refuerzo bajo el estante es del mismo acabado que el perfil extendo.

Q laccato/lacquered/laqué
lackiert/lacado

Y essenza/wood/bois
Holz/madera

X laccato metallo/metal lacquered
laqué metal/Metalllackierung
lacado metal

Q05 bianco/white
Q16 seta/silk
Q17 corda/ecru
Q20 ghisa/cast-iron
Q14 antracite/anthracite
Q04 nero/black
Q21 bronzo/bronze

Y36 rovere/oak
Y34 noce/walnut
Y37 rovere affumicato/smoked oak
Y38 rovere nero/black oak
Y40 frassino argilla/clay ash

X01 rame/copper
X02 ottone/brass
X03 titanio/titanium

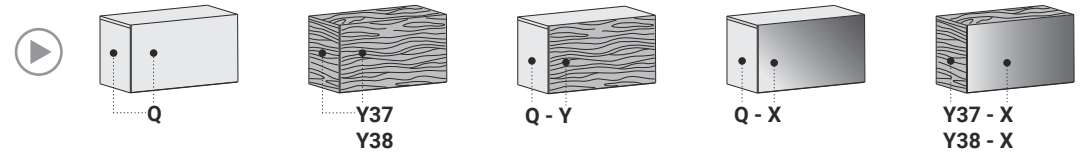

ANTA RIBALTA / FLAP DOOR / PORTE A ABATTANT / Klapptür / Puerta Abatible

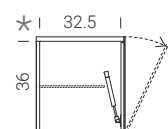
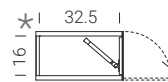
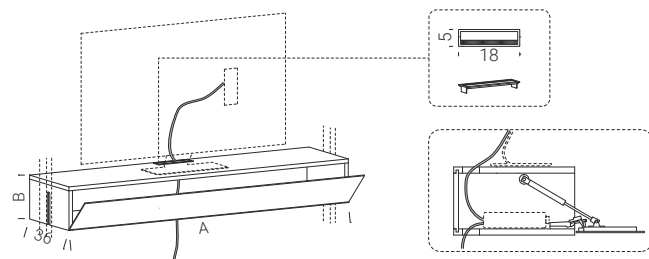
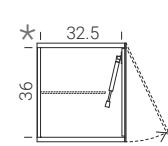
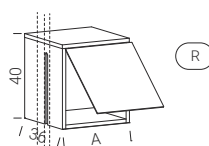
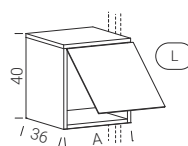
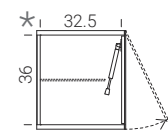
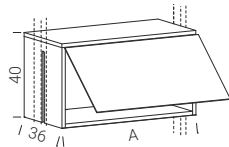
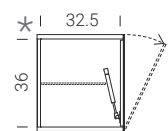
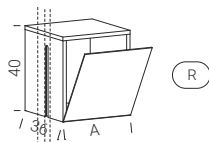
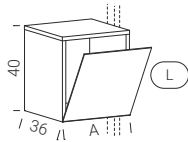
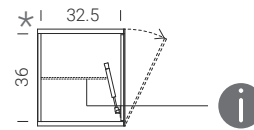
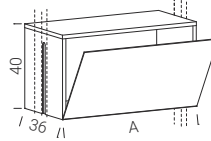
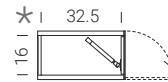
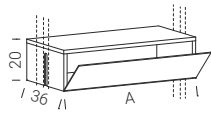

	A x 20	kg max	Q	Y37 Y38	Q-Y	Q-X	Y37-X Y38-X
PCAR0011	72 x 20	25	572	830	660	606	776
PCAR0012	108 x 20	30	683	990	788	723	925
PCAR0020	144 x 20	30	805	1167	929	852	1090

	A x 40	kg max	Q	Y37 Y38	Q-Y	Q-X	Y37-X Y38-X
PCAR0010	36 x 40	20	489	710	565	518	663
PCAR0008	72 x 40	25	669	969	771	708	906
PCAR0009	108 x 40	30	809	1173	933	856	1096
PCAR0021	144 x 40	30	925	1342	1068	979	1253

	A x 40	kg max	Q	Y37 Y38	Q-Y	Q-X	Y37-X Y38-X
PCAR0006	36 x 40	10	478	693	552	506	647
PCAR0007	36 x 40	10	478	693	552	506	647

	A x 40	kg max	Q	Y37 Y38	Q-Y	Q-X	Y37-X Y38-X
PCAR0025	36 x 40	20	489	710	565	518	663
PCAR0026	72 x 40	25	669	969	771	708	906
PCAR0027	108 x 40	30	809	1173	933	856	1096

	A x 40	kg max	Q	Y37 Y38	Q-Y	Q-X	Y37-X Y38-X
PCAR0023	36 x 40	10	478	693	552	506	647
PCAR0024	36 x 40	10	478	693	552	506	647

	A x B	kg max	Q	Y37 Y38	Q-Y	Q-X	Y37-X Y38-X
PCAR0017	72 x 20	25	584	846	676	618	791
PCAR0013	108 x 20	30	711	1032	821	753	964
PCAR0014	144 x 20	30	935	1356	1079	990	1267
PCAR0016	72 x 40	25	680	986	784	719	921
PCAR0015	108 x 40	30	837	1214	966	886	1134
PCAR0022	144 x 40	30	953	1370	1096	1007	1281



dimensioni interne
internal dimensions
dimensions internes
Innenmaße
dimensiones internas



ripiani interni non inclusi
internal shelves not included
étagères internes non incluses
Interne Einlegeböden nicht enthalten
estantes internos no incluidos



Sconsigliamo l'utilizzo delle ribalte e delle cassettiere in composizioni con asta telescopica extendo singola.
We advise you against using flap door cabinets and drawer units in compositions with a single extendo telescopic bar.
Nous déconseillons l'utilisation de compartiment avec porte à rabattant et de kits de tiroirs dans des compositions avec une seule barre télescopique extendo.
Wir nicht empfehlen, die behälter klapptüren und Schubladenelemente in Zusammensetzungen mit einem einzigen Teleskopstange extendo verwenden.
No se recomienda utilizar los módulos con puerta proyectante y los cajoneras en composiciones con una sola barra telescópica extendo.



Dettaglio anta
Detail of a door
Détail de la porte
Türdetail
Detalle de la puerta

Q laccato/lacquered/laqué
lackiert/lacado

Y essenza/wood/bois
Holz/madera

X laccato metallo/metal lacquered
laqué metal/Metalllackierung
lacado metal

- Q05** bianco/white
- Q16** seta/silk
- Q17** corda/ecru
- Q20** ghisa/cast-iron
- Q14** antracite/anthracite
- Q04** nero/black
- Q21** bronzo/bronze

- Y36** rovere/oak
- Y34** noce/walnut
- Y37** rovere affumicato/smoked oak
- Y38** rovere nero/black oak
- Y40** frassino argilla/clay ash

- X01** rame/copper
- X02** ottone/brass
- X03** titanio/titanium

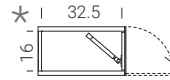
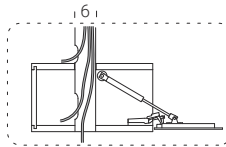
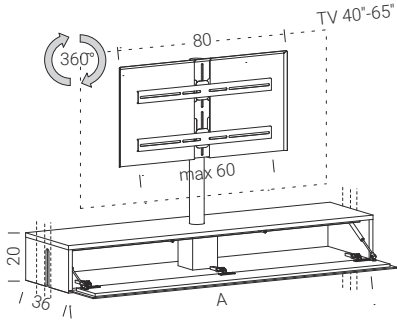
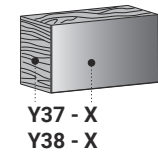
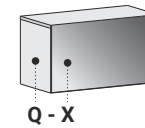
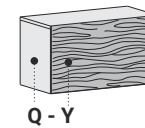
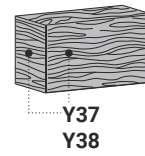
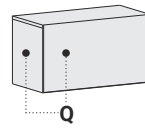

	A x 20	kg max	Q	Y37 Y38	Q-Y	Q-X	Y37-X Y38-X
PCAR0018	108 x 20	30	1019	1478	1176	1079	1381
PCAR0019	144 x 20	30	1278	1852	1474	1352	1730



supporto monitor universale per TV da 40 a 65 pollici.
universal monitor support for TV from 40 to 65 inches.
support moniteur universel pour TV de 40 à 65 pouces.
Universal-Monitor-Halter für TV von 40 bis 65 Zoll.
soporte de monitor universal para TV de 40 a 65 pulgadas.

CASSETTIERE / DRAWERS UNITS / KITS DE TIROIRS / SCHUBLADENELEMENTE / CAJONERAS

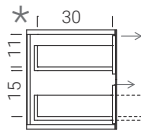
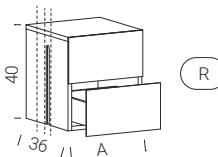
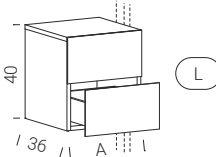
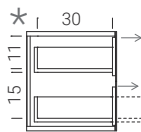
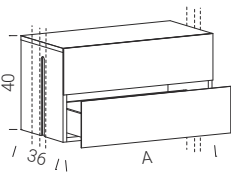
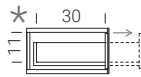
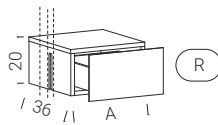
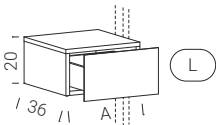
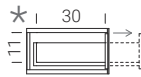
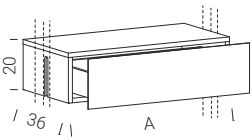

	A x 20	kg max	Q	Y37 Y38	Q-Y	Q-X	Y37-X Y38-X
PCSS0022	36 x 20	25	412	573	470	431	534
PCSS0023	72 x 20	25	521	725	595	546	676
PCSS0024	108 x 20	25	629	874	718	658	814

	A x 20	kg max	Q	Y37 Y38	Q-Y	Q-X	Y37-X Y38-X
PCSS0020	36 x 20	10	414	576	473	434	537
PCSS0021	36 x 20	10	414	576	473	434	537

	A x 40	kg max	Q	Y37 Y38	Q-Y	Q-X	Y37-X Y38-X
PCSS0019	36 x 40	25	576	800	657	603	746
PCSS0017	72 x 40	25	733	1018	836	767	949
PCSS0018	108 x 40	25	902	1253	1029	944	1168

	A x 40	kg max	Q	Y37 Y38	Q-Y	Q-X	Y37-X Y38-X
PCSS0015	36 x 40	10	567	788	647	593	734
PCSS0016	36 x 40	10	567	788	647	593	734



dimensioni interne
internal dimensions
dimensions internes
Innenmaße
dimensiones internas



Sconsigliamo l'utilizzo delle ribalte e delle cassettiere in composizioni con asta telescopica extendo singola.
We advise you against using flap door cabinets and drawer units in compositions with a single extendo telescopic bar.
Nous déconseillons l'utilisation de compartiment avec porte à rabattant et de kits de tiroirs dans des compositions avec une seule barre télescopique extendo.
Wir nicht empfehlen, die behälter klapptüren und Schubladenelemente in Zusammensetzungen mit einem einzigen Teleskopstange extendo verwenden.
No se recomienda utilizar los módulos con puerta proyectante y los cajoneras en composiciones con una sola barra telescópica extendo.

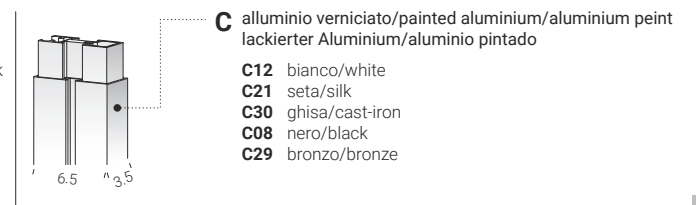
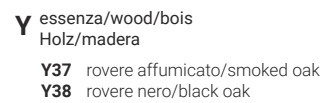
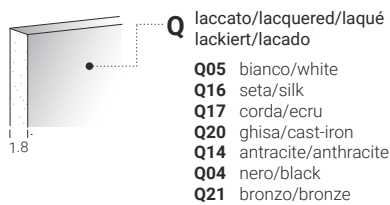
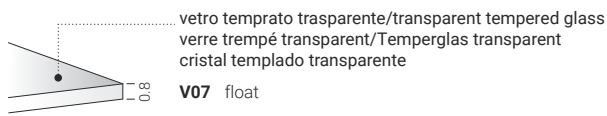

RIPIANI / SHELVES / ÉTAGÈRES / BÖDEN / ESTANTES

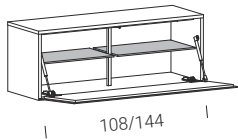
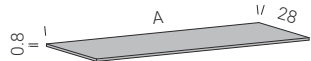
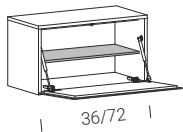

	A x 28	V07
ARIV0035	36 x 28	54
ARIV0036	72 x 28	63
ARIV0039	108 x 28	95
ARIV0040	144 x 28	110

forature per supporti ripiano da eseguire in opera Ø5 mm
holes for shelf supports to be drilled Ø5 mm
trous pour supports d'étagères à réaliser sur place Ø5 mm
Löcher für Einlegebodenhalter sind mit Ø5 mm vorzunehmen
orificios para soportes de baldas a realizar in situ Ø5 mm

PANNELLO RETRO CONTENITORE / CONTAINER BACK PANEL / PANNEAU ARRIÈRE CONTENEUR RÜCKSEITENPLATTEN TURM / PANEL POSTERIOR CONTENEDOR

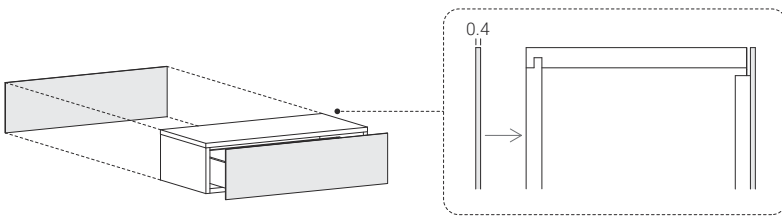

Per le composizioni bifacciali è disponibile un frontale del contenitore da utilizzare come pannello retro. **Prezzo su richiesta.**
For double-sided compositions, a container front panel is available that can be used as a back panel. **Price on request.**
Pour les compositions double face, une face avant du conteneur est disponible pour servir de panneau arrière. **Prix sur demande.**
Für die beidseitigen Kombinationen ist eine als Rückseitenplatte verwendbare Vorderseite des Turms verfügbar. **Preis auf Anfrage.**
Para las composiciones de doble cara está disponible un frontal del contenedor para usar como panel posterior. **Precio bajo petición.**

PANNELLO RETRO TV / TV REAR PANEL / PANNEAU ARRIÈRE TV RÜCKWAND TV / PANEL TRASERO TV

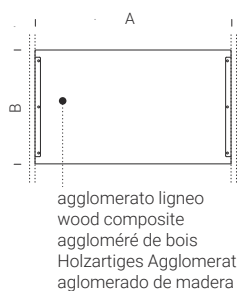
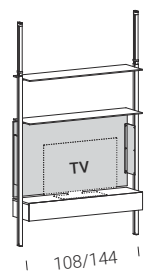

	A x B x 1,8	Q	Y37 Y38
PSEL0001	108 x 63 x 1,8	280	440
PSEL0002	144 x 84 x 1,8	392	531

COPPIA STAFFE SUPPORTO MONITOR ROTANTI / PAIR OF ROTATING MONITOR SUPPORT RODS DEUX ÉTRIERS DE SUPPORT ÉCRAN ROTATIFS / PAAR DREHHALTERUNGEN MONITORTRÄGER PAR DE FIJACIONES GIRATORIAS PARA SOPORTE MONITOR

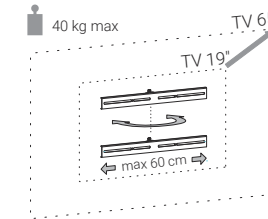
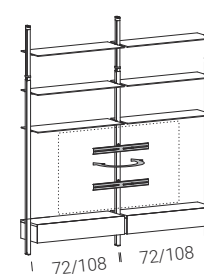

AACC0026	215
-----------------	-----

include 5 clip ferma cavo
includes 5 cable clips
comprend 5 clips de cable
enthält 5 Kabelclip-Clips
incluye 5 clips de cable

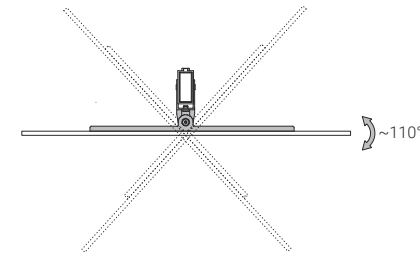

PROFILO RACCOGLI CAVI / PROFILE COLLECTS CABLES / PROFIL COLLECTE LES CÂBLES PROFIL SAMMELT KABEL / PERFIL RECOGE CABLES

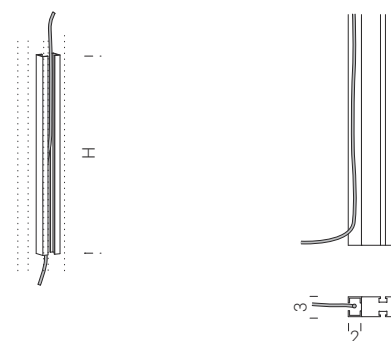

	A x B	H	
AACC0020	3 x 2	80	40
AACC0021	3 x 2	130	48
AACC0022	3 x 2	190	64

Utilizzabile con/Usable with/Utilisable avec
Verwendbar mit/Utilizable con

EXTE0001 EXTE0005
EXTE0011 EXTE0012 EXTE0013
EXTE0017 EXTE0018 EXTE0019

! il codice prevede una coppia di ripiani
the code includes two shelves
le code prévoit deux étagères
Artikelnummer sieht ein Einlegebodenpaar vor
el código prevé un par de estantes

✂️ disponibili riduzioni a misura
custom reductions available
réductions sur mesure disponibles
Verkürzungen auf Maß erhältlich
disponibles reducciones a medida

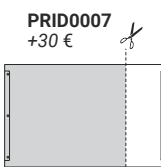

TV VESA 100x600
supporto monitor universale per TV da 40 a 65 pollici.
universal monitor support for TV from 40 to 65 inches.
support moniteur universel pour TV de 40 à 65 pouces.
Universal-Monitor-Halter für TV von 40 bis 65 Zoll.
soporte de monitor universal para TV de 40 a 65 pulgadas.

⚠️ Distanza max dei fori orizzontali di fissaggio sul retro del televisore (60 cm).
Max distance of the horizontal fixing holes on the back of the TV (60 cm).
Distance maximale des trous de fixation horizontaux sur l'arrière du téléviseur (60 cm).
Max Abstand der horizontalen Befestigungslöcher auf der Rückseite des TV (60 cm).
Distancia máxima de los agujeros de fijación horizontal en la parte posterior de la TV (60 cm).

TABLE MATERIALS

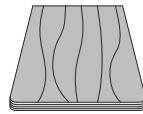

LE PAGINE SEGUENTI SI PROPONGONO COME UNA GUIDA ALLA SCELTA DI MATERIALI E FINITURE DEI TOP TAVOLI, ESPLORANDONE E COMPARANDONE CARATTERISTICHE QUALI PERFORMANCE DI RESISTENZA, MODALITÀ DI PULIZIA, RIPRISTINABILITÀ E COMPATIBILITÀ CON L'UTILIZZO IN OUTDOOR.

The following pages are offered as a guide for choosing the materials and finishes of the table tops, exploring and comparing their features, such as resistance performance, cleaning methods, restorability and compatibility with use in outdoor spaces.

Les pages suivantes se proposent comme un guide au choix des matériaux et des finitions des plateaux de tables, en explorant et en comparant leurs caractéristiques comme les performances de résistance, les modalités de nettoyage, le rétablissement et la compatibilité avec l'utilisation à l'extérieur.

Die folgenden Seiten gelten als Leitfaden für die Auswahl der Materialien und Ausführungen der Tischplatten (Top), wobei deren Eigenschaften wie z. B. Widerstandsfähigkeit, Reinigungsmethoden, Renovierung und Kompatibilität hinsichtlich der Outdoor-Verwendung geprüft und verglichen werden.

Las siguientes páginas se proponen como una guía para la elección de materiales y acabados de las partes superiores de las mesas, explorando y comparando sus características como el rendimiento de resistencia, los métodos de limpieza, la capacidad de restauración y la compatibilidad con el uso en exteriores.

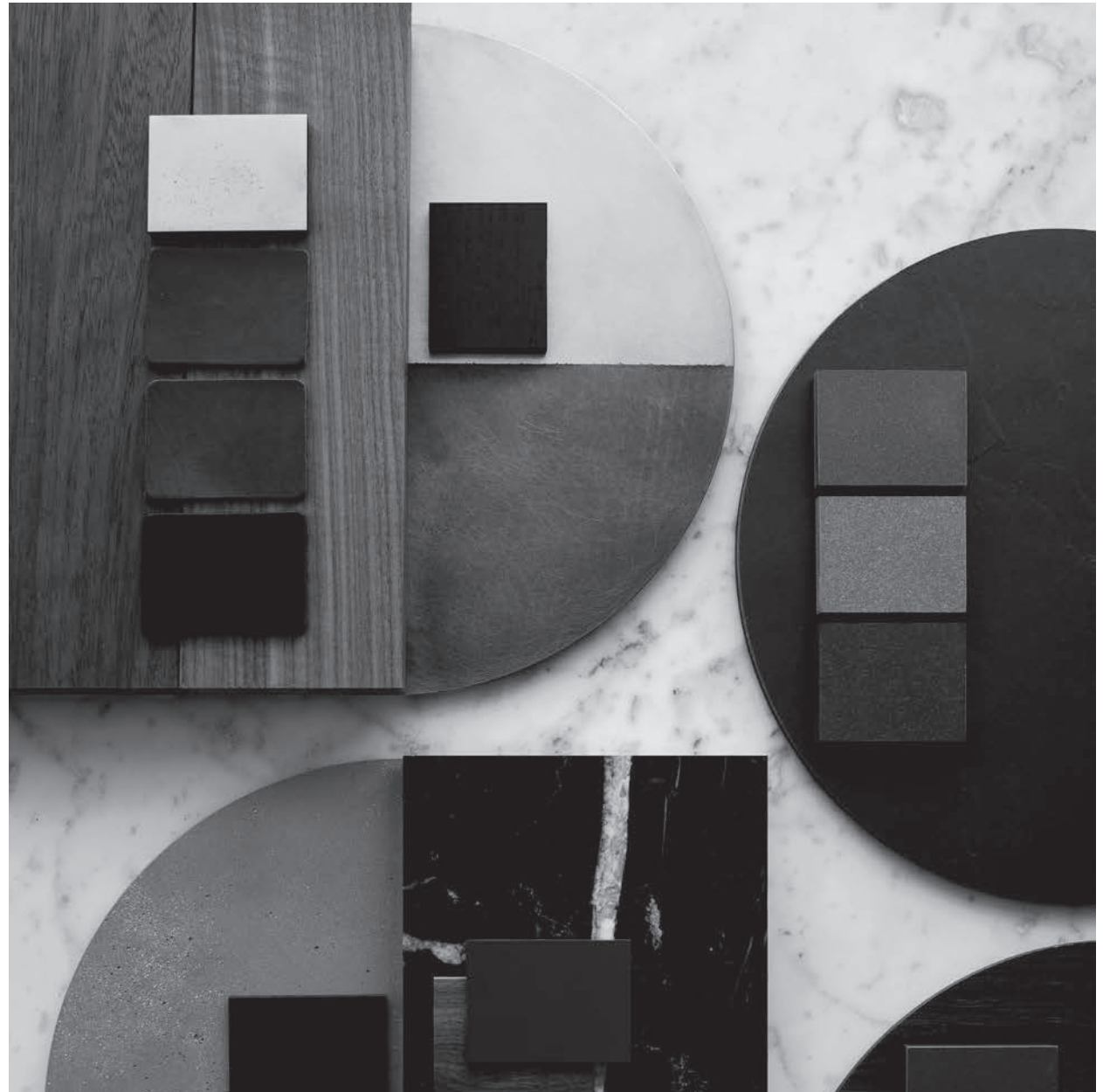

Caratteristiche tecniche
Technical characteristics
Caractéristiques techniques
Technische merkmale
Características técnicas



tolleranza per altezza totale tavoli pari a $\pm 1\%$
total height of tables tolerance $\pm 1\%$
tolérance de hauteur totale des tables $\pm 1\%$
Gesamthöhentoleranz Tische von $\pm 1\%$
tolerancia para altura total mesas igual a $\pm 1\%$



**MATERIALI E FINITURE / MATERIALS AND FINISHES / MATÉRIAUX ET FINITIONS
MATERIALIEN UND AUSFÜHRUNGEN / MATERIALES Y ACABADOS**

LEGNO MASSICCIO | SOLID WOOD



- T01 rovere / oak
- T02 noce / walnut
- T03 iroko
- T04 iroko outdoor
- T05 rovere nero / black oak

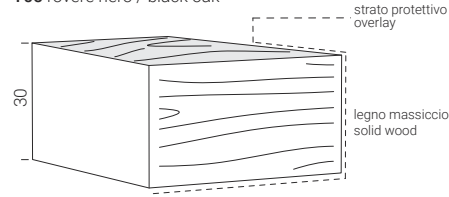

La superficie in legno viene trattata con uno strato di vernice all'acqua (olio per outdoor).
Le tavole in legno massiccio sono sottoposte ad un processo di essiccazione per garantirne la stabilità nel tempo. La tecnica di giuntatura a pettine 'finger-joint' contribuisce alla costruzione di un pannello che mantiene la planarità.

The wooden surface is treated with a layer of water-based paint (oil for outdoors).
The solid wood boards are subjected to a drying process to ensure their stability over time. The 'finger-joint' technique contributes to the construction of a panel that maintains flatness.

POLARIS®



- L03 HPL bianco / white HPL
- L10 grigio chiaro / light grey
- L11 grigio scuro / dark grey

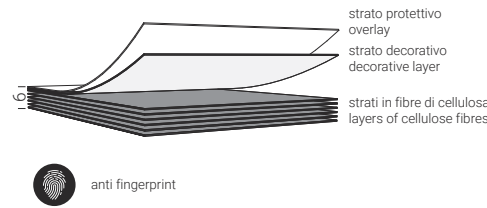

La superficie in finitura POLARIS grazie al trattamento con nanotecnologie è resistente al graffio, morbida al tatto e anti-impronta. Il pannello in HPL full-color di spessore 6mm è costituito da strati di fibre di cellulosa impregnati con resine termoindurenti sottoposti ad un processo di alta pressione (90 kg/cm²) ed alta temperatura (150°C).

The Polaris finish surface, thanks to the nanotechnology treatment, is scratch-proof, soft-to-the-touch and anti-fingerprint. The 6 mm thick full-color HPL panel is made of cellulose fibre layers impregnated with thermosetting resins subject to a high pressure (90 kg/cm²) and high temperature (150°C) process.

HPL+METALLO | HPL+METAL

- C31 ottone / brass
- C32 ottone scuro / dark brass
- C35 inox / inox
- C36 inox scuro / dark inox

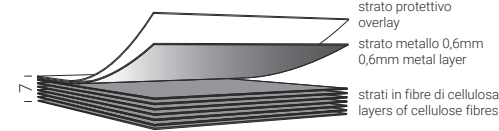

C31/C32 impronte e liquidi, accelerano il naturale processo di ossidazione
C31/C32 fingerprints and liquids accelerate the natural oxidation process

La superficie in ottone/acciaio inox di spessore 0.6 mm ha una lavorazione manuale di spazzolatura vintage; l'ottone è protetto da un film in cera d'api.
Il supporto in HPL è costituito da strati di fibre di cellulosa impregnati con resine termoindurenti sottoposti ad un processo di alta pressione (90 kg/cm²) ed alta temperatura (150°C).

The 0.6 mm thick brass/stainless steel surface has a vintage manually brushed finish; the brass is protected by a film of beeswax.
The support in HPL made of cellulose fibre layers impregnated with thermosetting resins subject to a high pressure (90 kg/cm²) and high temperature (150°C) process.

HPL+ECOTOUCH

- N01 sabbia / sand
- N02 basalto / basalt

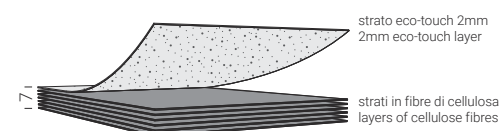

antibatterico antibacterial

anti fingerprint

La superficie in eco-touch di spessore 2 mm è un impasto di origine organica 100% naturale (sughero, juta, olio di lino).
Il supporto in HPL è costituito da strati di fibre di cellulosa impregnati con resine termoindurenti sottoposti ad un processo di alta pressione (90 kg/cm²) ed alta temperatura (150°C).

The 2 mm thick eco-touch surface is a mixture of organic origin and 100% natural (cork, jute, linseed oil).
The support in HPL made of cellulose fibre layers impregnated with thermosetting resins subject to a high pressure (90 kg/cm²) and high temperature (150°C) process.

FENIX®

- L08 grigio Londra / London grey
- L06 nero / black

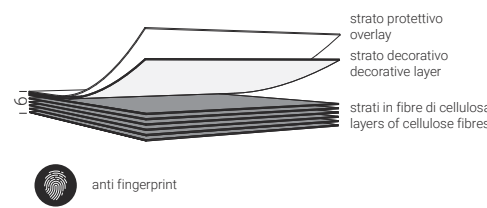

La superficie in finitura Fenix grazie al trattamento con nanotecnologie è resistente al graffio, morbida al tatto e anti-impronta. Il pannello in HPL full-color di spessore 6mm è costituito da strati di fibre di cellulosa impregnati con resine termoindurenti sottoposti ad un processo di alta pressione (90 kg/cm²) ed alta temperatura (150°C).

The Fenix finish surface, thanks to the nanotechnology treatment, is scratch-proof, soft-to-the-touch and anti-fingerprint. The 6 mm thick full-color HPL panel is made of cellulose fibre layers impregnated with thermosetting resins subject to a high pressure (90 kg/cm²) and high temperature (150°C) process.

HPL+CEMENTO | HPL+CONCRETE



- D01 bianco calce / lime white
- D02 grigio Portland / Portland grey
- D03 nero / black

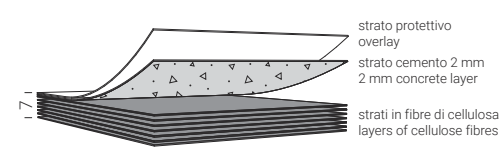

Il processo produttivo manuale genera superfici irregolari.
The manual production process creates irregular surfaces.

anti fingerprint

La superficie in cemento di spessore 2mm è un impasto composto da sabbie, inerti e resine, resiste agli impatti e non assorbe i liquidi.
Il supporto in HPL (high-pressure laminates) è un pannello costituito da strati di fibre di cellulosa impregnati con resine termoindurenti sottoposti ad un processo ad alta pressione (90 kg/cm²) ed alta temperatura (150 °C).

The 2 mm thick cement surface is a paste comprising sand, inert materials and resins, withstands impacts and does not absorb liquids.
The support in HPL made of cellulose fibre layers impregnated with thermosetting resins subject to a high pressure (90 kg/cm²) and high temperature (150°C) process.

HPL+LEGNO | HPL+WOOD



- Y36 rovere / oak
- Y34 noce / walnut
- Y37 rovere affumicato / smoked oak
- Y40 frassino argilla / clay ash
- Y39 frassino nero / black ash

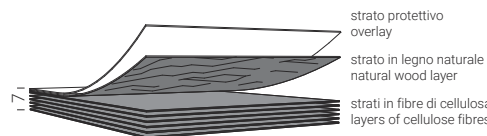

La superficie in legno naturale di spessore 0.6 mm è protetto da una verniciatura all'acqua antigraffio.
Il supporto in HPL è costituito da strati di fibre di cellulosa impregnati con resine termoindurenti sottoposti ad un processo di alta pressione (90 kg/cm²) ed alta temperatura (150°C).

The 0.6 mm thick natural wood surface is protected by scratch-resistant water-based paint.
The support in HPL made of cellulose fibre layers impregnated with thermosetting resins subject to a high pressure (90 kg/cm²) and high temperature (150°C) process.

CERAMICA LAMINAM® | CERAMIC LAMINAM®



- S05 antracite / anthracite
- S06 nero / black
- S07 porfido / porfido
- S08 cardoso / cardoso

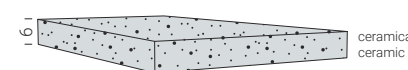

Laminam IN-SIDE è un impasto ceramico di ultima generazione, la cui colorazione di superficie è presente in massa in tutto lo spessore. La superficie ha elevati standard di resistenza al graffio, e per aumentarne la resistenza all'impatto e la sicurezza in caso di rottura, lo strato ceramico è accoppiato ad una rete in fibra di vetro.

Laminam IN-SIDE is a state-of-the-art ceramic paste whose surface colouring permeates its entire thickness. The surface is scratch-proof and the ceramic layer is coupled to a fibreglass panel to increase its resistance to impact and breakage.

**MORFOLOGIA FINITURE TOP TAVOLI / MORPHOLOGY OF TABLE TOP FINISHES / MORPHOLOGIE DES FINITIONS DES PLATEAUX DE TABLES
MORPHOLOGIE DER TOP-AUSFÜHRUNGEN / MORFOLOGÍA DE ACABADOS DE LAS PARTES SUPERIORES DE LAS MESAS**

Le caratteristiche evidenziate nelle seguenti schede sono da considerarsi parte integrante della materia prima o del processo produttivo adottato.
The features highlighted in the following data sheets are to be considered an integral part of the raw material or of the production process adopted.

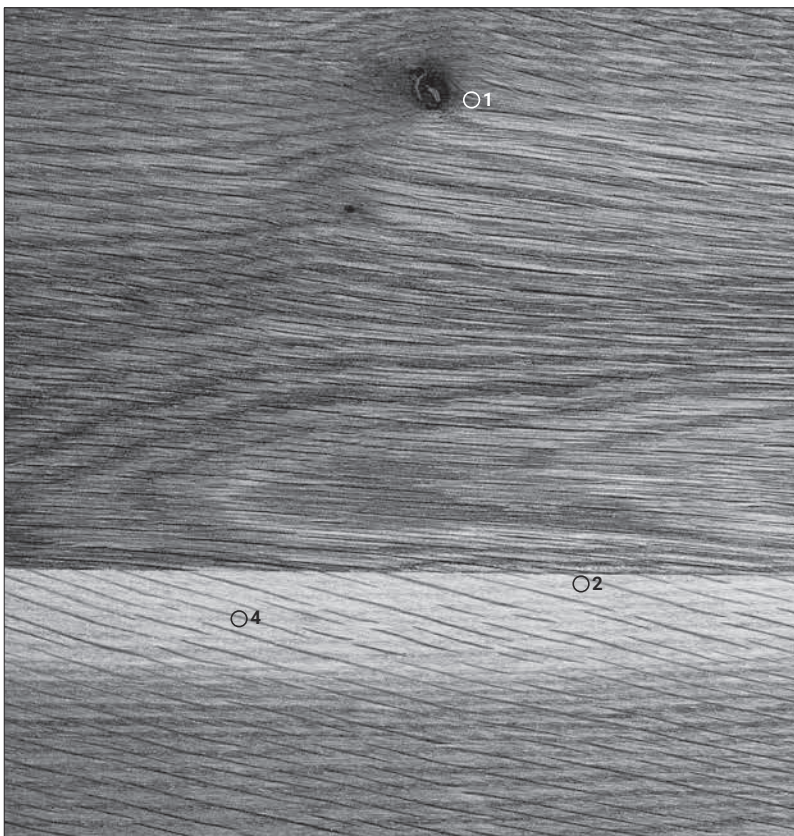





LEGNO MASSICCIO / SOLID WOOD

- T01 rovere / oak
- T02 noce / walnut
- T03 iroko
- T04 iroko outdoor
- T05 rovere nero/black oak



CARATTERISTICHE DI SUPERFICIE / SURFACE FEATURES

-  **1** piccoli nodi o stuccature in tinta
small knots or plastering of the same colour
-  **2** fessurazioni derivanti dal grado di umidità-temperatura presente nell'ambiente
cracks resulting from the degree of humidity-temperature present in the environment
-  **3** deformazioni di superficie non soggetta a carico inferiori a 4 mm per metro lineare
deformations of a surface not subjected to loads of less than 4 mm per linear metre
-  **4** alterazione cromatica (ossidazione) delle superfici causata dalla luce e degli agenti atmosferici propri dell'ambiente
changes in colour (oxidation) of surfaces caused by light and atmospheric agents typical of the environment
-  **5** Lo spessore complessivo finale dei top in massello ha una tolleranza di 2/3 millimetri sul valore riportato a listino. I tavoli con top in massello hanno un incremento dell'altezza complessiva variabile da 0.5 a 2.5cm.
The overall final thickness of the solid wood top has a tolerance of 2/3 millimetres compared to the value indicated in the price list. The tables with solid wood top have a greater overall height of between 0.5 and 2.5 cm.

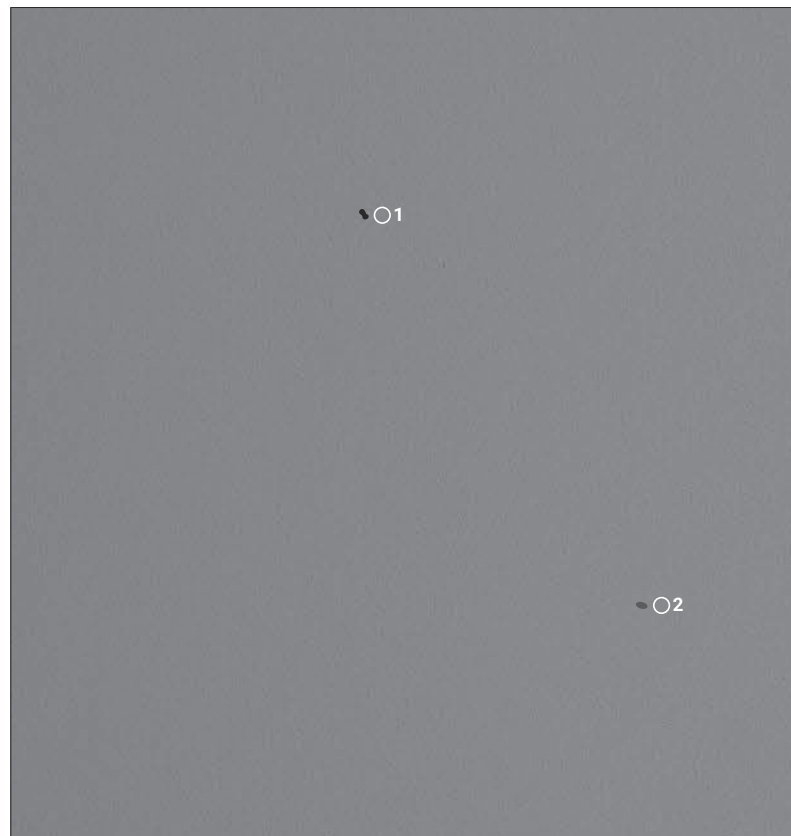

POLARIS®

- L03 bianco / white
- L10 grigio chiaro / light grey
- L11 grigio scuro / dark grey



FENIX®

- L08 grigio Londra / London grey
- L06 nero / black



anti fingerprint

CARATTERISTICHE DI SUPERFICIE / SURFACE FEATURES

-  **1** micro inclusioni che non superano 1 mm² su 1 m²
micro inclusions that does not exceed 1 mm² of every 1 m²
-  **2** carenze di materia che non superano 1 mm² su 1 m²
missing material that does not exceed 1 mm² of every 1 m²
-  **3** deformazioni di superficie non soggetta a carico inferiori a 2 mm per metro lineare
deformations of a surface not subjected to loads of less than 2 mm per linear metre

Le caratteristiche evidenziate nelle seguenti schede sono da considerarsi parte integrante della materia prima o del processo produttivo adottato.
The features highlighted in the following data sheets are to be considered an integral part of the raw material or of the production process adopted.

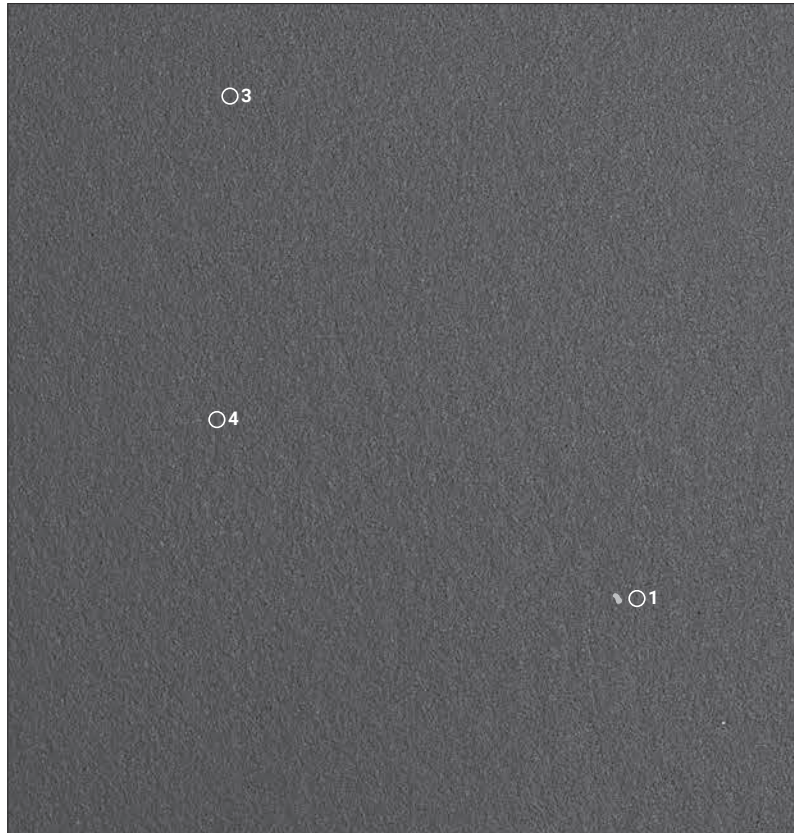

HPL+ECO-TOUCH

N01 sabbia / sand
N02 basalto / basalt



anti fingerprint



antibatterico
antibacterial

CARATTERISTICHE DI SUPERFICIE / SURFACE FEATURES



1 micro inclusioni o carenze di materia che non superano 1mm² su 1m²
micro inclusions or missing material that does not exceed 1 mm² of every 1 m²



2 deformazioni di superficie non soggetta a carico inferiori a 2 mm per metro lineare
deformations of a surface not subjected to loads of less than 2 mm per linear metre



3 la struttura della superficie morbida al tatto evidenzia il composto delle materie prime che la costituiscono (sughero, fibre di juta e olio di lino)
the structure of the surface soft to the touch highlights the compound of the raw materials that it is composed of (cork, jute fibres and linseed oil)



4 inclusioni di impasto visibili in superficie
mixture inclusions visible on the surface

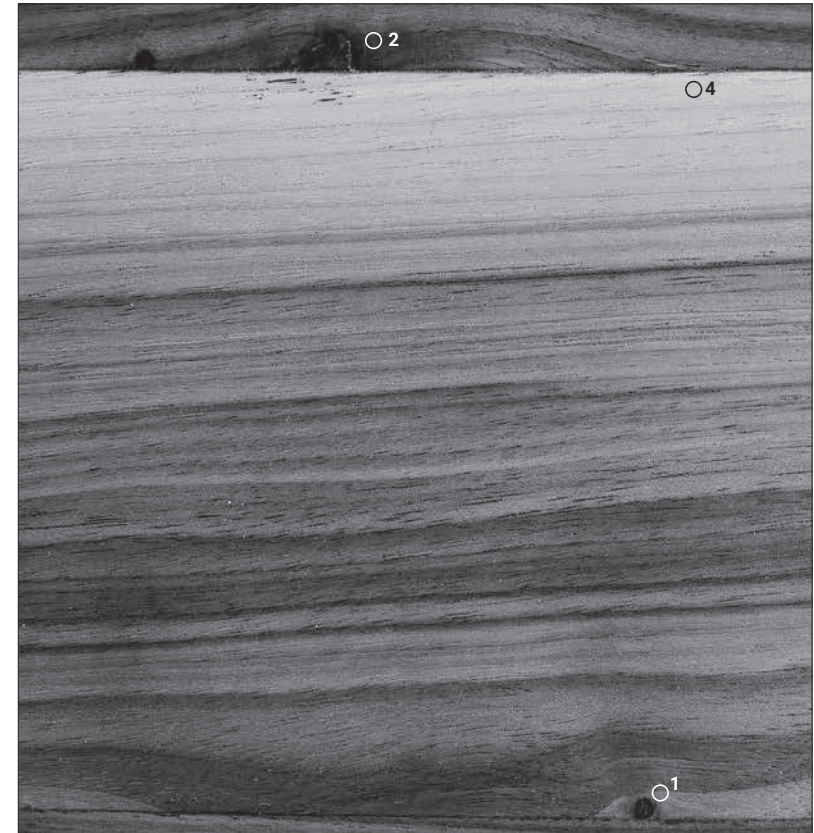

HPL+LEGNO | HPL+WOOD

Y34 noce / walnut
Y36 rovere / oak
Y37 rovere affumicato / smoked oak

Y40 frassino argilla / clay ash
Y39 frassino nero / black ash



CARATTERISTICHE DI SUPERFICIE / SURFACE FEATURES



1 piccoli nodi o stucature in tinta
small knots or plastering of the same colour



2 fessurazioni derivanti dal grado di umidità-temperatura presente nell'ambiente
cracks resulting from the degree of humidity-temperature present in the environment



3 deformazioni di superficie non soggetta a carico inferiori a 2 mm per metro lineare
deformations of a surface not subjected to loads of less than 2 mm per linear metre



4 alterazione cromatica (ossidazione) delle superfici causata dalla luce e degli agenti atmosferici propri dell'ambiente
changes in colour (oxidation) of surfaces caused by light and atmospheric agents typical of the environment

Le caratteristiche evidenziate nelle seguenti schede sono da considerarsi parte integrante della materia prima o del processo produttivo adottato.
The features highlighted in the following data sheets are to be considered an integral part of the raw material or of the production process adopted.

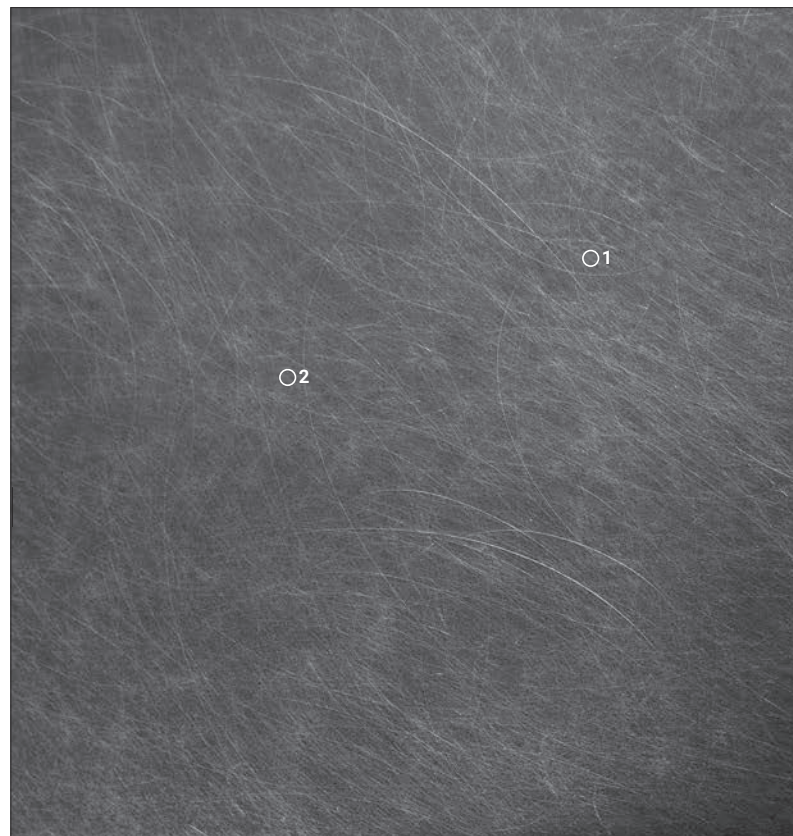
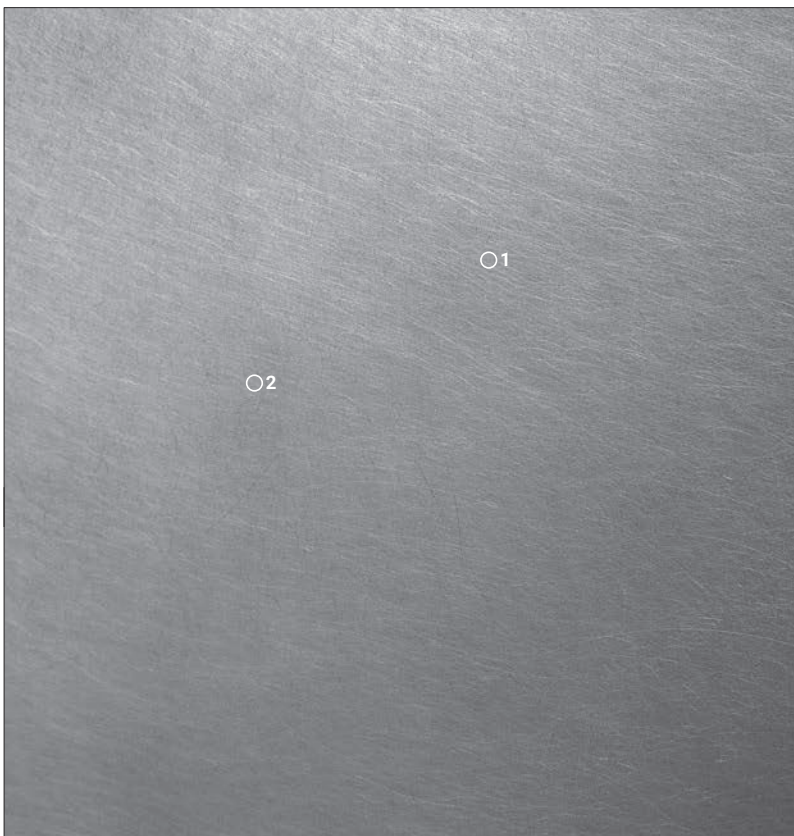





HPL+METALLO | HPL+METAL

C31 ottone / brass
C32 ottone scuro / dark brass



HPL+METALLO | HPL+METAL

C35 inox / inox
C36 inox scuro / dark inox

CARATTERISTICHE DI SUPERFICIE / SURFACE FEATURES

- 
1 la spazzolatura manuale genera una superficie non uniforme ma con effetto vintage
manual brushing produces an uneven surface but with a vintage effect
- 
2 le aree cromatiche non omogenee sono frutto del processo di ossidazione graduale naturale (C31-C35) o accelerato tramite brunitore (C32-C36)
the non-homogeneous areas of colour are the result of the gradual natural oxidation process (C31-C35) or are accelerated by a burnisher (C32-C36)
- 
3 deformazioni di superficie non soggetta a carico inferiori a 2 mm per metro lineare
deformations of a surface not subjected to loads of less than 2 mm per linear metre
- 
4 la superficie in ottone è sensibile ad impronte e liquidi che possono accelerare il processo naturale di ossidazione. Non lasciare asciugare le macchie.
the brass surface is sensitive to fingerprints and liquids that can accelerate the natural oxidation process. Do not leave stains to dry.

CARATTERISTICHE DI SUPERFICIE / SURFACE FEATURES

- 
1 la spazzolatura manuale genera una superficie non uniforme ma con effetto vintage
manual brushing produces an uneven surface but with a vintage effect
- 
2 le aree cromatiche non omogenee sono frutto del processo di ossidazione graduale naturale (C31-C35) o accelerato tramite brunitore (C32-C36)
the non-homogeneous areas of colour are the result of the gradual natural oxidation process (C31-C35) or are accelerated by a burnisher (C32-C36)
- 
3 deformazioni di superficie non soggetta a carico inferiori a 2 mm per metro lineare
deformations of a surface not subjected to loads of less than 2 mm per linear metre

Le caratteristiche evidenziate nelle seguenti schede sono da considerarsi parte integrante della materia prima o del processo produttivo adottato.
The features highlighted in the following data sheets are to be considered an integral part of the raw material or of the production process adopted.

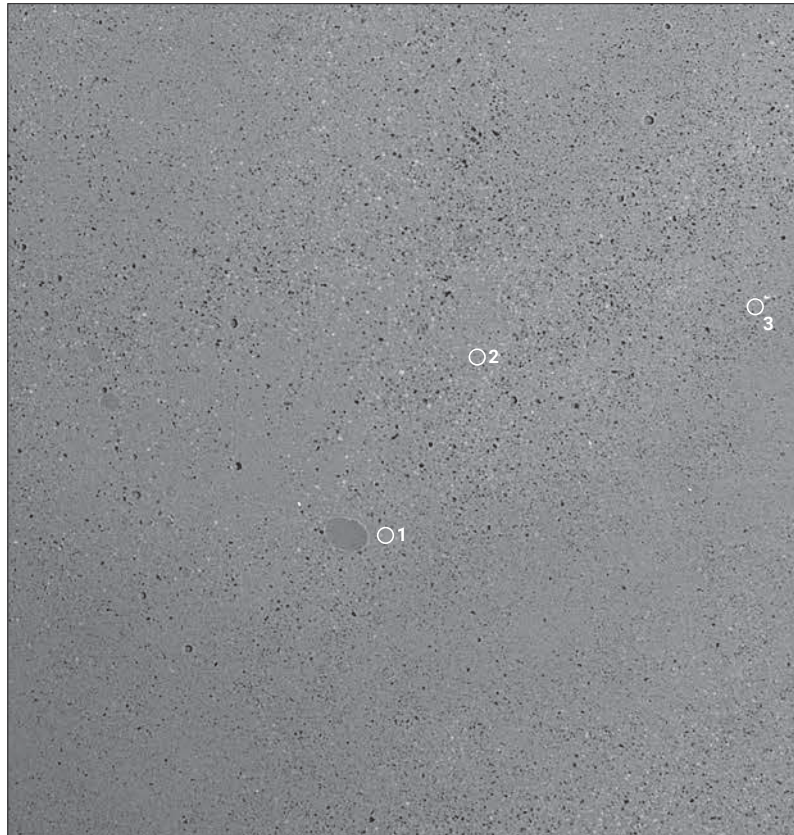





HPL+CEMENTO | HPL+CONCRETE

D01 bianco calce / lime white
D02 grigio Portland / Portland grey
D03 nero / black



anti fingerprint

CARATTERISTICHE DI SUPERFICIE / SURFACE FEATURES

- 1  carenze di materia derivanti da bolle d'aria imprigionate in fase di colata del cemento, colmate con resina trasparente
material deficiencies deriving from air bubbles trapped during the cement casting, filled with transparent resin.
- 2  deformazioni di superficie non soggetta a carico inferiori a 2 mm per metro lineare
deformations of a surface not subjected to loads of less than 2 mm per linear metre
- 3  colorazione non omogenea di superficie che evidenzia la presenza di materiali inerti con diversa natura (sabbie/cemento)
non-homogeneous surface colour that highlights the presence of inert materials of a different nature (sands/cement)
- 4  superficie con spessore variabile
surface with variable thickness

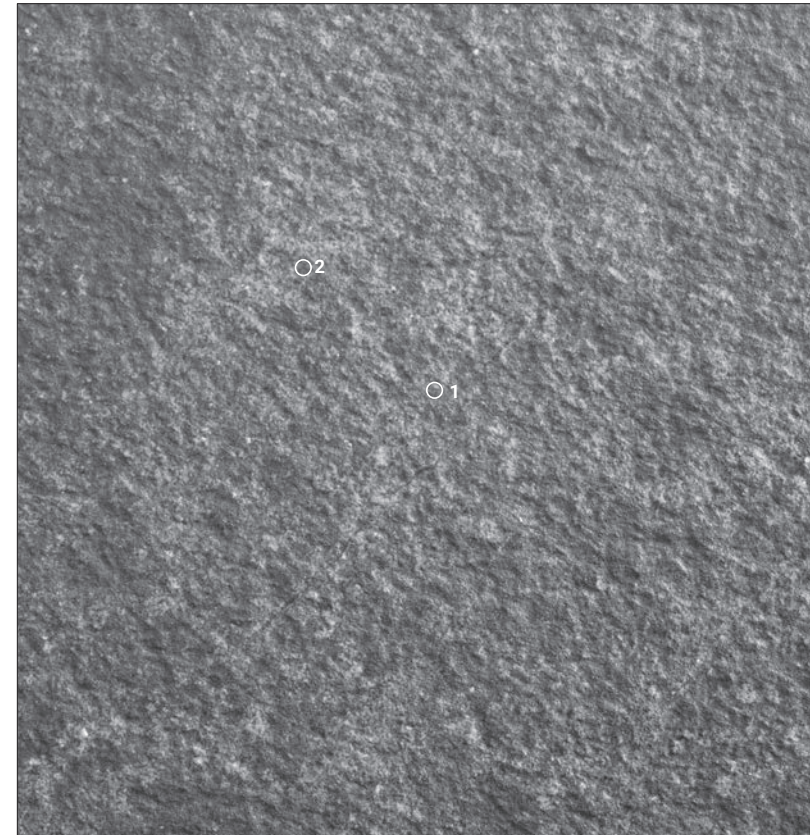



CERAMICA LAMINAM® | CERAMIC LAMINAM®

S05 antracite / anthracite **S07** porfido / porfido
S06 nero / black **S08** cardoso / cardoso



CARATTERISTICHE DI SUPERFICIE / SURFACE FEATURES

- 1  La superficie delle finiture S07 e S08 esalta la matericità della pietra a spacco, la superficie è comunque facilmente pulibile
The surface of the S07 and S08 finishes enhances the texture of the split stone, the surface is easy to clean in any case
- 2  Le aree cromatiche non omogenee nelle finiture S07-S08 sono espressione estetica della pietra a spacco, mentre nelle finiture S05-S06 rappresentano la finitura "calce"
The non-uniform chromatic areas in the S07 and S08 finishes are an aesthetic expression of the split stone, while in the S05-S06 finishes they represent the "whitewash" finish
- 3  La fibra di vetro incrociata presente nella superficie inferiore ha la funzione di rendere il foglio ceramico molto più resistente a flessione e agli impatti, rendendo sicura la lastra in caso di rottura
The criss cross fibre glass on the lower surface has the purpose of making the ceramic sheet much more resistant to bending and impacts and safe in the case of breakage

CARATTERISTICHE TECNICHE TOP TAVOLI / TABLE TOP TECHNICAL FEATURES / CARACTÉRISTIQUES TECHNIQUES DES PLATEAUX DE TABLES
 TECHNISCHE EIGENSCHAFTEN DER TOP / CARACTERÍSTICAS TÉCNICAS DE LAS PARTES SUPERIORES DE LAS MESAS

TABLE MATERIALS

performance



		spessore thickness (cm)	impatto impact	acqua water	calore heat	graffio scratch	macchie stains	pulizia cleaning up	ripristinabilità recoverability	uso outdoor outdoor use
NEW LEGNO MASSICCIO SOLID WOOD	T01/T02/T03/T05 rovere/noce/iroko/rovere nero oak/walnut/iroko/black oak	3	●●●●○	●●●●○	●○○○○	●●○○○	●●●○○	P2	R1	—
	T04 iroko outdoor iroko outdoor	3	●●●●○	●●●●○	●○○○○	●●○○○	●●●○○	P5	R6	✓
NEW POLARIS®	L03/L10/L11 bianco/grigio chiaro/grigio scuro white/light grey/dark grey	0.6	●●●●●	●●●●●	●●●●○	●●●●○	●●●●●	P1	NC	✓
FENIX®	L08/06 grigio Londra/nero London grey/black	0.6	●●●●●	●●●●●	●●●●○	●●●●○	●●●●●	P1	NC	✓
NEW HPL+LEGNO HPL+WOOD	Y36/Y34/Y37/Y39/Y40 rovere/noce/rovere affumicato/frassino nero/ frassino argilla oak/walnut/smoked oak/black ash/clay ash	0.7	●●●●○	●●●●○	●○○○○	●●○○○	●●●○○	P2	R1	—
HPL+METALLO HPL+METAL	C31/C32 ottone/ottone scuro brass/dark brass	0.7	●●●●○	●○○○○	●●●●●	●●●●○	●○○○○	P3	R2	—
	C35/C36 inox/inox scuro inox/dark inox	0.7	●●●●●	●●●●●	●●●●●	●●●●○	●●●●●	P4	NC	✓
HPL+ECOTOUCH	N01/N02 sabbia/basalto eco-touch sand/basalt eco-touch	0.7	●●●○○	●●●○○	●●●○○	●○○○○	●●●○○	P4	R3	—
NEW HPL+CEMENTO HPL+CONCRETE	D01/D02/D03 bianco calce/grigio Portland/nero lime white/Portland grey/black	0.7	●●●●○	●●●●●	●●●●○	●●●●○	●●●●○	P4	R5	✓
NEW CERAMICA LAMINAM® CERAMIC LAMINAM®	S05/S06/S07/S08 antracite/nero/porfido/cardoso anthracite/black/porfido/cardoso	0.6	●●○○○	●●●●●	●●●●●	●●●●●	●●●●●	P4	NC	✓



compatibilità con l'ambiente / environmental compatibility

tutte le materie prime utilizzate nella realizzazione dei prodotti derivano da un processo di riutilizzo e sono a loro volta riciclabili
 all the raw materials used to create the products are the result of a process of re-use and are, in turn, recyclable
 toutes les matières premières utilisées dans la réalisation des produits dérivent d'un processus de réutilisation et sont à leur tour recyclables
 Alle, bei der Produktherstellung verwendeten Rohstoffe, stammen aus einem Wiederverwendungsprozess und sind ihrerseits wiederum recycelbar
 todas las materias primas utilizadas en la producción de los productos se derivan de un proceso de reutilización y, a su vez, son reciclables



uso outdoor / outdoor use

esterno riparato
 sheltered outdoor
 extérieur protégé
 draußen geschützt
 exterior reparado

performance

- bassa/low/basse/niedrig/bajo
- media/medium/moyenne/mittelmäßig/promedio
- buona/good/bonne/gut/bueno
- ottima/very good/très bonne/ausgezeichnet/excelente
- eccellente/excellent/excellente/ exzellent/excelente

- P1** Vaporizzare detergente neutro e pulire con spugna magica bianca.
Spray neutral detergent and clean with a white magic sponge.
Vaporiser le détergent neutre et nettoyer avec une éponge magique blanche.
Einsprühen mit neutralem Reinigungsmittel und mit einem weißen Zauberschwamm reinigen.
Rocío detergente neutro y limpie con una esponja mágica blanca.
- P2** Vaporizzare detergente neutro e pulire con un panno morbido. Trattare successivamente con un prodotto adatto alle superfici lignee.
Spray neutral detergent and clean with a soft cloth. Then treat with a product suitable for wooden surfaces.
Vaporiser le détergent neutre et nettoyer avec un chiffon moelleux. Traiter ensuite avec un produit adapté aux surfaces en bois.
Einsprühen mit neutralem Reinigungsmittel und mit einem weichen Tuch säubern. Anschließend mit einem geeigneten Produkt für Holzoberflächen behandeln.
Rocío detergente neutro y limpie con un paño suave. Luego trate con un producto adecuado para superficies de madera.
- P3** Vaporizzare detergente neutro e pulire con un panno morbido. Saltuariamente si consiglia di applicare un sottile strato di cera d'api, lasciare asciugare e rimuovere la patina di cera essiccata in eccesso.
Spray neutral detergent and clean with a soft cloth. Occasionally, it is advisable to apply a thin layer of beeswax, allow to dry and remove the excess coating of dried wax.
Vaporiser le détergent neutre et nettoyer avec un chiffon moelleux. De temps en temps, nous conseillons d'appliquer une fine couche de cire d'abeille, de laisser sécher et d'éliminer la patine de cire séchée en excès.
Einsprühen mit neutralem Reinigungsmittel und mit einem weichen Tuch säubern. Es wird empfohlen, gelegentlich eine dünne Schicht Bienenwachs aufzutragen, diese trocknen zu lassen und dann die überschüssige Patina aus getrocknetem Wachs zu entfernen.
Rocío detergente neutro y limpie con un paño suave. Ocasionalmente, se recomienda aplicar una capa delgada de cera de abejas, dejar secar y eliminar la pátina del exceso de cera seca.
- P4** Vaporizzare detergente neutro e pulire con un panno morbido.
Spray neutral detergent and clean with a soft cloth.
Vaporiser le détergent neutre et nettoyer avec un chiffon moelleux.
Einsprühen mit neutralem Reinigungsmittel und mit einem weichen Tuch säubern.
Rocío detergente neutro y limpie con un paño suave.
- P5** Vaporizzare detergente neutro e pulire con un panno morbido. Saltuariamente si consiglia di applicare un sottile strato protettivo di olio per la protezione del legno in outdoor.
Spray neutral detergent and clean with a soft cloth. Occasionally, it is advisable to apply a thin protective layer of oil in order to protect the wood in outdoor spaces.
Vaporiser le détergent neutre et nettoyer avec un chiffon moelleux. De temps en temps, nous conseillons d'appliquer une fine couche de protection d'huile pour protéger le bois à l'extérieur.
Einsprühen mit neutralem Reinigungsmittel und mit einem weichen Tuch säubern. Es wird empfohlen, gelegentlich eine dünne Schutzschicht aus Öl zum Schutz des Holzes bei Outdoor-Verwendung aufzutragen.
Rocío detergente neutro y limpie con un paño suave. Ocasionalmente, se recomienda aplicar una fina capa protectora de aceite para proteger la madera en exteriores.

- NC** Non si consiglia alcun tipo di operazione di ripristino.
No type of restoration operation is recommended.
Nous ne conseillons aucun type d'opération de rétablissement.
Es wird keinerlei Art der Renovierung empfohlen.
No se recomienda ningún tipo de recuperación.
- R1** **graffi lievi** : applicare un sottile strato di cera d'api.
graffi profondi: carteggiare l'intera superficie lignea seguendo il verso di venatura dell'essenza e applicare un film protettivo di vernice all'acqua anti-graffio.
slight scratches: apply a thin layer of beeswax.
deep scratches: sand the entire wooden surface following the direction of the grain of the wood and apply a protective film of water-based anti-scratch paint.
éraflures légères : appliquer une fine couche de cire d'abeille.
éraflures profondes : poncer toute la surface du bois en suivant le sens de ses veines et appliquer un film de protection de peinture à l'eau anti-éraflure.
leichte Kratzer: eine dünne Schicht Bienenwachs auftragen.
tiefe Kratzer: Schleifen Sie die gesamte Holzoberfläche in Richtung der Holzmaserung ab und tragen Sie einen Schutzfilm aus kratzfester Farbe auf Wasserbasis auf.
arañazos leves: aplique una capa delgada de cera de abejas.
arañazos profundos: lije toda la superficie de madera siguiendo la dirección del grano de la esencia y aplique una película protectora de pintura antiarañazos a base de agua.
- R2** **graffi lievi**: applicare un sottile strato di cera d'api.
graffi profondi: ri-spazzolare manualmente l'intera superficie con una spugna Scotch-Brite, rimuovere accuratamente l'ossido di ottone con alcool, applicare un sottile strato di cera d'api con un panno morbido.
slight scratches: apply a thin layer of beeswax.
deep scratches: manually re-brush the entire surface with a Scotch-Brite sponge, carefully remove the brass oxide with alcohol, apply a thin layer of beeswax with a soft cloth.
éraflures légères : appliquer une fine couche de cire d'abeille.
éraflures profondes : brosser de nouveau manuellement toute la surface avec une éponge Scotch-Brite, éliminer soigneusement l'oxyde de laiton avec de l'alcool, appliquer une fine couche de cire d'abeille avec un chiffon moelleux.
leichte Kratzer: eine dünne Schicht Bienenwachs auftragen.
tiefe Kratzer: Bürsten Sie die gesamte Oberfläche manuell mit einem Scotch-Brite-Schwamm ab, entfernen Sie sorgfältig das Messingoxid mit Alkohol und tragen Sie eine dünne Schicht Bienenwachs mit einem weichen Tuch auf.
arañazos leves: aplique una capa delgada de cera de abejas.
arañazos profundos: vuelva a cepillar manualmente toda la superficie con una esponja Scotch-Brite, retire cuidadosamente el óxido de latón con alcohol, aplique una capa delgada de cera de abejas con un paño suave.
- R3** **graffi lievi**: applicare un sottile strato di olio paglierino.
graffi profondi: carteggiare con carta vetrata a grana fine (220-240) e ri-applicare il trattamento di olio paglierino.
light scratches: apply a thin layer of paglierino furniture oil.
deep scratches: sand with fine grain sandpaper (220-240) and re-apply the paglierino furniture oil treatment.
éraflures légères: appliquer une fine couche d'huile de paille.
éraflures profondes: poncer avec du papier de verre à grain fin (220-240) et appliquer de nouveau le traitement à l'huile de paille.
leichte Kratzer: eine dünne Schicht Strohöl auftragen.
tiefe Kratzer: Mit feinkörnigem Schleifpapier (Körnung 220-240) abschleifen und die Behandlung mit Strohöl erneut wiederholen.
arañazos leves: aplique una fina capa de aceite de paja.
arañazos profundos: lije con papel de lija de grano fino (220-240) y vuelva a aplicar el tratamiento de aceite de paja.

- R4** **graffi lievi/profondi/distaccamenti**: applicare un sottile strato di trattamento idro oleo-repellente per pietra.
light/deep scratches/detachments: apply a thin layer of water-oil repellent treatment for stone.
éraflures légères/profondes/détachements: appliquer une fine couche de traitement hydrofuge-oléofuge pour la pierre.
leichte / tiefe Kratzer / Ablösungen: Tragen Sie eine dünne Schicht einer wasser-ölabweisenden Behandlung für Naturstein auf.
arañazos ligeros/profundos/desprendimientos: aplique una capa delgada de tratamiento repelente de hidrocarburos para piedra.
- R5** **graffi lievi**: applicare un sottile strato di cera d'api.
graffi profondi: carteggiare con carta vetrata a grana fine (220-240) e ri-applicare un sottile strato di cera d'api con un panno morbido.
light scratches: apply a thin layer of beeswax.
deep scratches: sand with fine-grained sandpaper (220-240) and re-apply a thin layer of beeswax with a soft cloth.
éraflures légères: appliquer une fine couche de cire d'abeille.
éraflures profondes: poncer avec un papier de verre à grain fin (220-240) et appliquer de nouveau une fine couche de cire d'abeille à l'aide d'un chiffon doux.
leichte Kratzer: eine dünne Schicht Bienenwachs auftragen.
tiefe Kratzer: Mit feinkörnigem Schleifpapier (Körnung 220-240) abschleifen und erneut eine dünne Schicht Bienenwachs mit einem weichen Tuch auftragen.
arañazos leves: aplique una capa delgada de cera de abejas.
arañazos profundos: lije con papel de lija de grano fino (220-240) y vuelva a aplicar una capa delgada de cera de abejas con un paño suave.
- R6** **graffi lievi/profondi**: carteggiare la superficie parzialmente o interamente seguendo il verso di venatura dell'essenza e applicare un film protettivo di olio specifico per la protezione del legno in outdoor.
light/deep scratches: sand the surface partially or entirely, following the direction of the grain of the wood and apply a protective film of oil, specific for protecting wood in outdoor spaces.
éraflures légères/profondes: poncer la surface partiellement ou complètement en suivant le sens des veines du bois et appliquer un film de protection d'huile spécifique pour la protection du bois à l'extérieur.
leichte / tiefe Kratzer: Schleifen Sie die Oberfläche teilweise oder vollständig in Richtung der Holzmaserung ab und tragen Sie einen Schutzfilm aus Öl auf, das speziell für den Outdoor-Holzschutz entwickelt wurde.
arañazos leves/profundos: lije la superficie parcial o totalmente siguiendo la dirección del grano de la esencia y aplique una película protectora de aceite específica para la protección de la madera en exteriores.

SPILLO

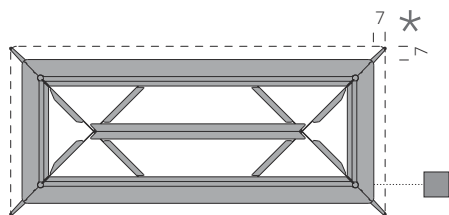

geometrie disponibili/available shapes
géométries disponibles/Verfügbare Formen
geometrías disponibles

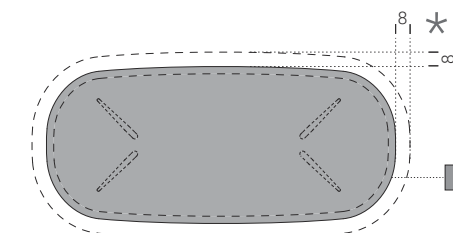

geometrie disponibili/available shapes
géométries disponibles/Verfügbare Formen
geometrías disponibles

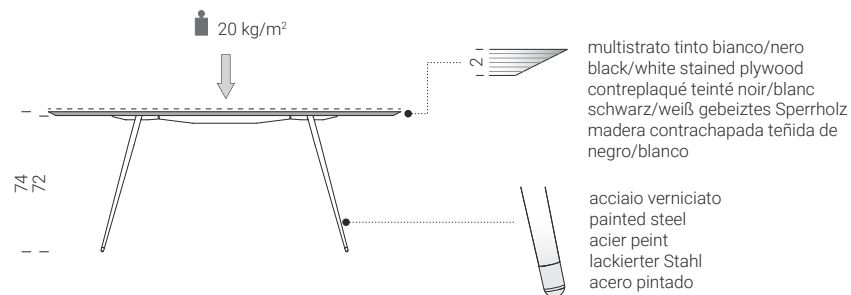
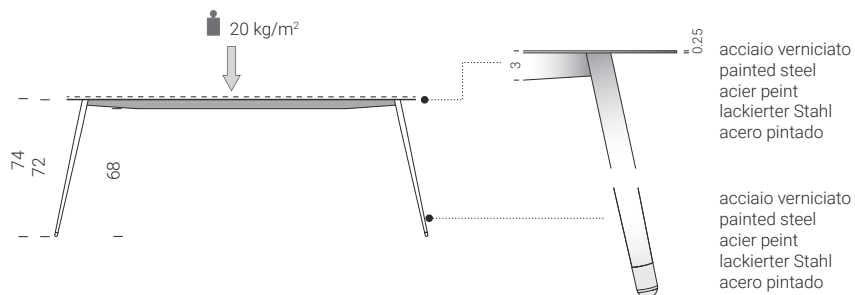

BALANCE

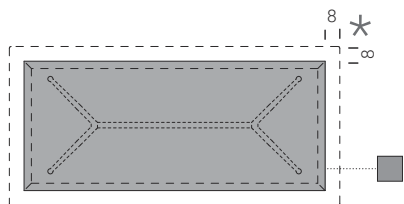

geometrie disponibili/available shapes
géométries disponibles/Verfügbare Formen
geometrías disponibles

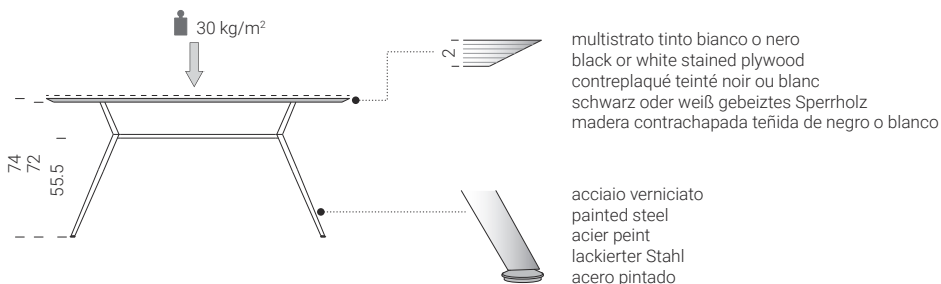
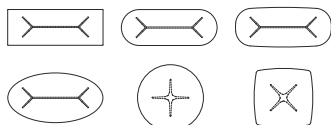

T7

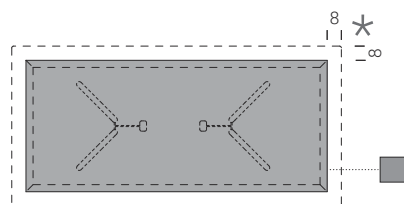

geometrie disponibili/available shapes
géométries disponibles/Verfügbare Formen
geometrías disponibles

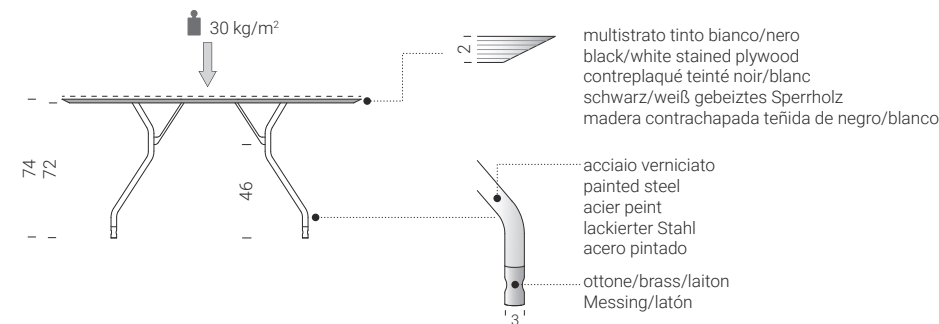
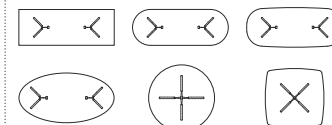

per prezzi dei telai vedi pagina relativa alla collezione
for frame prices, see the page pertaining to the collection
pour les prix des bâtis, voir la page relative à la collection
Zu den Preisen der Rahmen konsultieren Sie die Seite der Kollektion
para precios de marcos, ver la página de la colección



peso massimo al metro quadro del top di finitura
maximum weight per square metre of the finishing top
poids maximum au mètre carré du plateau de finition
Höchstgewicht pro Quadratmeter der Abdeckplatte
peso máximo por metro cuadrado de la encimera de acabado



il top di finitura appoggia nell'area evidenziata
the finished top rests in the highlighted area
le plateau de finition repose dans la zone mise en évidence
Das behandelte Top liegt auf dem hervorgehobenen Bereich
la parte superior de acabado descansa en el área resaltada



differenza di dimensione tra top e sottotop fornito
difference in size between top and under-top supplied
différence de taille entre le plateau et le sous-plateau fourni
Größenunterschied zwischen gelieferter Abdeckplatte und Unterbau
diferencia de tamaño entre la encimera y la parte inferior de la encimera

SINTESI TABLE AND BENCH

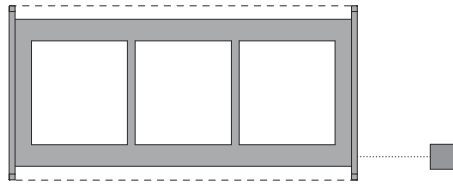

⚠️ disponibile solo per tavoli fissi
available for fixed tables only
disponible uniquement pour les tables fixes
nur für feste Tische verfügbar
disponible solo para mesas fijas



⚠️ disponibile solo per panche fisse
available for fixed benches only
disponible uniquement pour les bancs fixes
nur für feste Bänke verfügbar
disponible solo para banquillos fijos

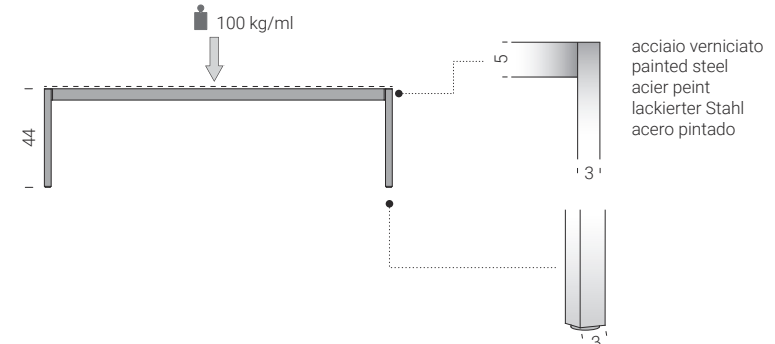
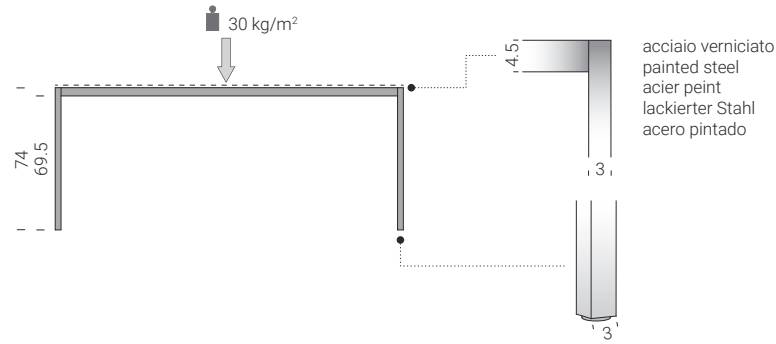

ST35 TABLE AND BENCH

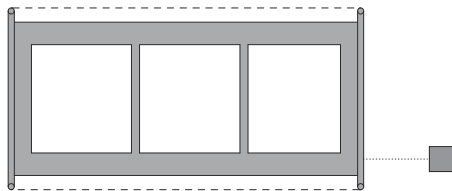

⚠️ disponibile solo per tavoli fissi
available for fixed tables only
disponible uniquement pour les tables fixes
nur für feste Tische verfügbar
disponible solo para mesas fijas



⚠️ disponibile solo per panche fisse
available for fixed benches only
disponible uniquement pour les bancs fixes
nur für feste Bänke verfügbar
disponible solo para banquillos fijos

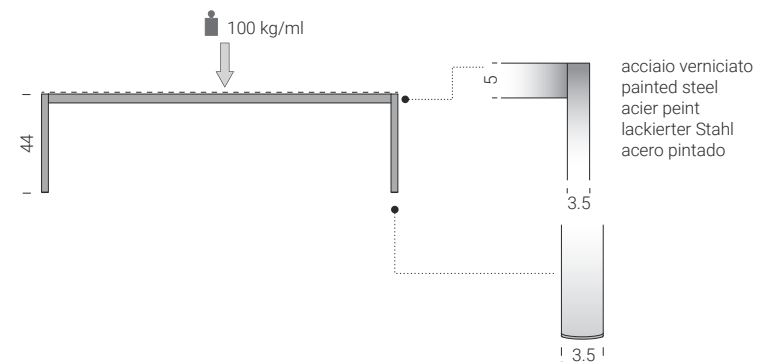
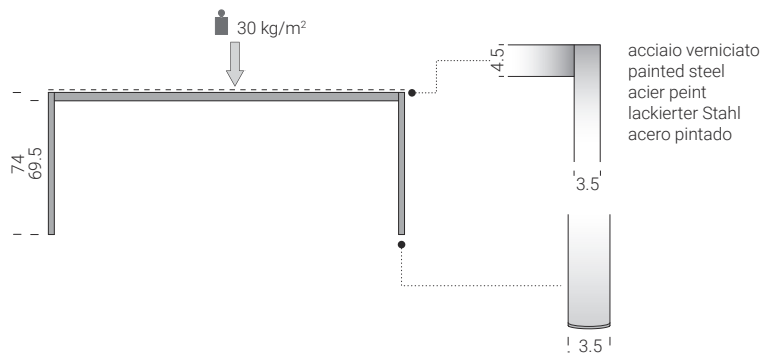

per prezzi dei telai vedi pagina relativa alla collezione
for frame prices, see the page pertaining to the collection
pour les prix des bâtis, voir la page relative à la collection
Zu den Preisen der Rahmen konsultieren Sie die Seite der Kollektion
para precios de marcos, ver la página de la colección



peso massimo al metro quadro del top di finitura
maximum weight per square metre of the finishing top
poids maximum au mètre carré du plateau de finition
Höchstgewicht pro Quadratmeter der Abdeckplatte
peso máximo por metro cuadrado de la encimera de acabado



il top di finitura appoggia nell'area evidenziata
the finished top rests in the highlighted area
le plateau de finition repose dans la zone mise en évidence
Das behandelte Top liegt auf dem hervorgehobenen Bereich
la parte superior de acabado descansa en el área resaltada

T8 TABLE AND BENCH

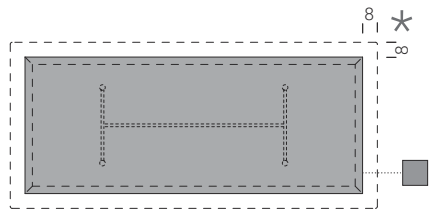

geometrie disponibili/available shapes
géométries disponibles/Verfügbare Formen
geometrías disponibles

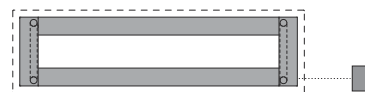
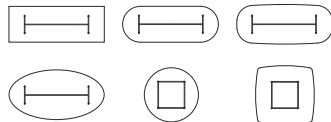

disponibile solo per panche fisse
available for fixed benches only
disponible uniquement pour les bancs fixes
nur für feste Bänke verfügbar
disponible solo para banquillos fijos

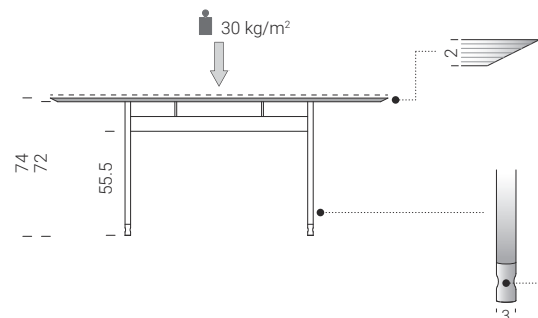

multistrato tinto bianco o nero
black or white stained plywood
contreplaqué teinté noir ou blanc
schwarz oder weiß gebeiztes Sperrholz
madera contrachapada teñida de negro o blanco

acciaio verniciato
painted steel
acier peint
lackierter Stahl
acero pintado

ottone/brass/laiton
Messing/latón

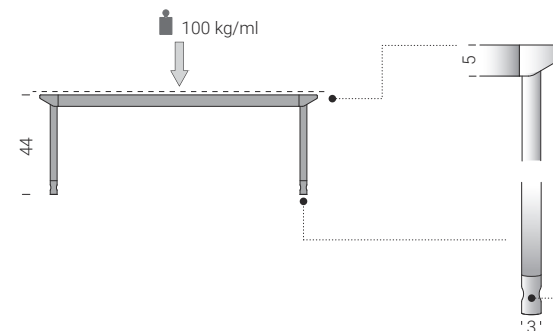

multistrato tinto bianco/nero
black/white stained plywood
contreplaqué teinté noir/blanc
schwarz/weiß gebeiztes Sperrholz
madera contrachapada teñida de negro/blanco

acciaio verniciato
painted steel
acier peint
lackierter Stahl
acero pintado

ottone/brass/laiton
Messing/latón

T9

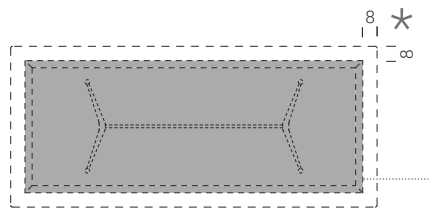

geometrie disponibili/available shapes
géométries disponibles/Verfügbare Formen
geometrías disponibles

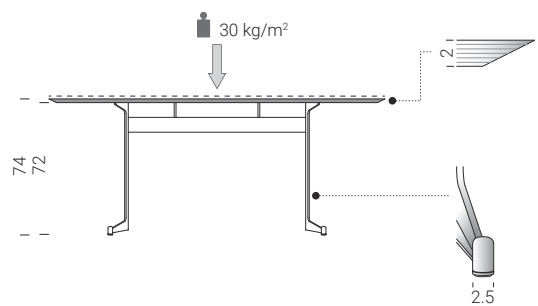
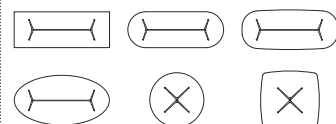

multistrato tinto bianco o nero
black or white stained plywood
contreplaqué teinté noir ou blanc
schwarz oder weiß gebeiztes Sperrholz
madera contrachapada teñida de negro o blanco

acciaio verniciato
painted steel
acier peint
lackierter Stahl
acero pintado

T10

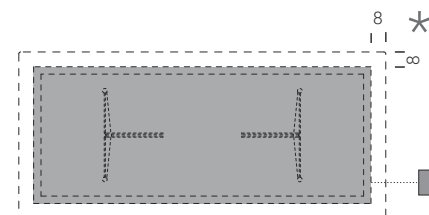

geometrie disponibili/available shapes
géométries disponibles/Verfügbare Formen
geometrías disponibles

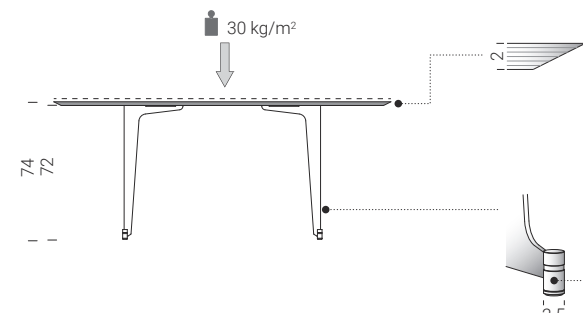
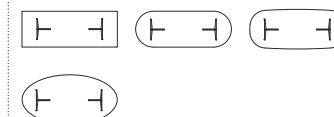

multistrato tinto bianco o nero
black or white stained plywood
contreplaqué teinté noir ou blanc
schwarz oder weiß gebeiztes Sperrholz
madera contrachapada teñida de negro o blanco

acciaio verniciato
painted steel
acier peint
lackierter Stahl
acero pintado

ottone/brass/laiton
Messing/latón



per prezzi dei telai vedi pagina relativa alla collezione
for frame prices, see the page pertaining to the collection
pour les prix des bâtis, voir la page relative à la collection
Zu den Preisen der Rahmen konsultieren Sie die Seite der Kollektion
para precios de marcos, ver la página de la colección



peso massimo al metro quadro del top di finitura
maximum weight per square metre of the finishing top
poids maximum au mètre carré du plateau de finition
Höchstgewicht pro Quadratmeter der Abdeckplatte
peso máximo por metro cuadrado de la encimera de acabado



il top di finitura appoggia nell'area evidenziata
the finished top rests in the highlighted area
le plateau de finition repose dans la zone mise en évidence
Das behandelte Top liegt auf dem hervorgehobenen Bereich
la parte superior de acabado descansa en el área resaltada



differenza di dimensione tra top e sottotop fornito
difference in size between top and under-top supplied
différence de taille entre le plateau et le sous-plateau fourni
Größenunterschied zwischen gelieferter Abdeckplatte und Unterbau
diferencia de tamaño entre la encimera y la parte inferior de la encimera

T11

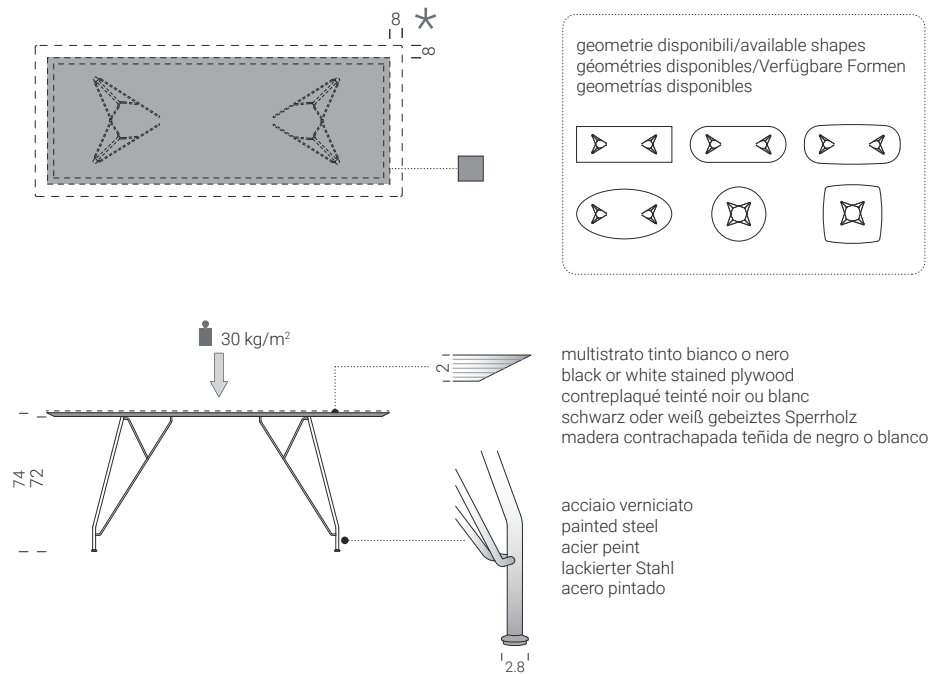

DÉCO

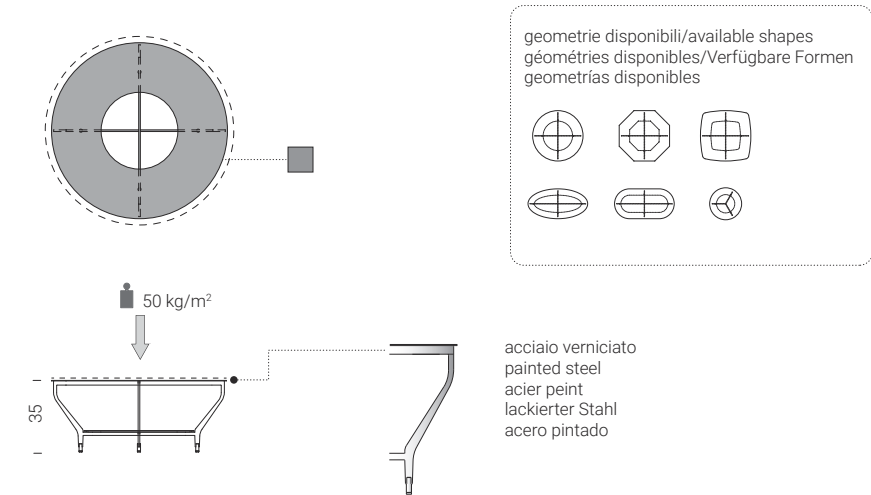

per prezzi dei telai vedi pagina relativa alla collezione
for frame prices, see the page pertaining to the collection
pour les prix des bâtis, voir la page relative à la collection
Zu den Preisen der Rahmen konsultieren Sie die Seite der Kollektion
para precios de marcos, ver la página de la colección



peso massimo al metro quadro del top di finitura
maximum weight per square metre of the finishing top
poids maximum au mètre carré du plateau de finition
Höchstgewicht pro Quadratmeter der Abdeckplatte
peso máximo por metro cuadrado de la encimera de acabado



il top di finitura appoggia nell'area evidenziata
the finished top rests in the highlighted area
le plateau de finition repose dans la zone mise en évidence
Das behandelte Top liegt auf dem hervorgehobenen Bereich
la parte superior de acabado descansa en el área resaltada



differenza di dimensione tra top e sottotop fornito
difference in size between top and under-top supplied
différence de taille entre le plateau et le sous-plateau fourni
Größenunterschied zwischen gelieferter Abdeckplatte und Unterbau
diferencia de tamaño entre la encimera y la parte inferior de la encimera

BALANCE

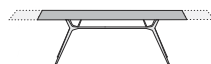

IL SUPPORTO IN ACCIAIO DEI TAVOLI BALANCE COSTITUISCE LA BASE DI UN SISTEMA DI TELAI IN GRADO DI ADATTARSI IN MODO ARMONICO E PROPORZIONATO A TUTTE LE GEOMETRIE DEI TOP DISPONIBILI. LA SEZIONE TRIANGOLARE DERIVA DALLA COMPRESSIONE DI TUBI A SEZIONE CIRCOLARE IN ACCIAIO, TALE COMPRESSIONE AUMENTA LA RESISTENZA DEL SUPPORTO, CONFERENDOGLI UNA SILHOUETTE ELEGANTE E LEGGERA.

The steel support of the Balance tables forms the base of a frame system capable of easily adapting to all the geometries of the tops available. The triangular section comes from compressing circular steel tubes. Such compression increases the strength of the support, giving it an elegant and light silhouette.

Le support en acier des tables balance constitue la base d'un système de structures en mesure de s'adapter de manière harmonieuse et proportionnée à toutes les géométries des plateaux disponibles. La section triangulaire dérive de la compression de tubes à section circulaire en acier, cette compression augmente la résistance du support en lui conférant une silhouette élégante et légère.

Die Stahlbeine der Tische balance bilden die Basis eines Rahmensystems, das sich allen Formen der angebotenen Abschlussborde harmonisch und proportioniert anpasst. Der dreieckige Querschnitt entsteht aus dem Druck der Stahlrohre mit rundem Querschnitt. Dieser Druck erhöht die Festigkeit des Halters und verleiht ihm eine elegante und leichte Silhouette.

El soporte de acero de las mesas Balance constituye la base de un sistema de bastidores que puede adaptarse armoniosamente proporcionado sobrees disponibles para todo tipo de geometría. La sección triangular deriva de la compresión de tubos de acero de sección circular. Dicha compresión aumenta la resistencia del soporte, confiriéndole una silueta elegante y ligera.



Disponibili riduzioni a misura
Custom reductions available
Réductions sur mesure disponibles
Verkürzungen auf Maß erhältlich
Disponibles reducciones a medida



Passacavo disponibile per tutti i top
Cable gland available for all tops
Passe-câble disponible pour tous les plateaux
Kabeldurchlass für alle Abschlussborde verfügbar
Pasacables disponible para todos los sobrees



Uso in esterno riparato
Use in a sheltered outdoor space
Utilisation en extérieur, en espace abrité
Verwendung in geschütztem Außenbereich
Uso exterior protegido



EXTENDABLE
TABLE SYSTEM
registered community
design

- acciaio verniciato/painted steel/acier peint
lackierter Stahl/acero pintado
- C12** bianco/white
 - C21** seta/silk
 - C23** corda/ecru
 - C30** ghisa/cast-iron
 - C14** antracite/anthracite
 - C08** nero/black
 - C18** verde/green
 - C26** corten/corten
 - C29** bronzo/bronze
 - C37** rame/copper
 - C38** titanio/titanium

- ceramica/ceramic/c eramique
Keramik/cer mico
- S05** antracite/anthracite
 - S06** nero/black
 - S07** porfido/porfido
 - S08** cardoso/cardoso

- HPL POLARIS 
- L03** bianco/white
 - L10** grigio chiaro/light grey
 - L11** grigio scuro/dark grey
- HPL FENIX 
- L08** grigio Londra/London grey
 - L06** nero/black

- HPL+ legno/wood/bois/Holz/madera
- Y36** rovere/oak
 - Y34** noce/walnut
 - Y37** rovere affumicato/smoked oak
 - Y39** frassino nero/black ash
 - Y40** frassino argilla/clay ash

TAVOLI ALLUNGABILI / EXTENDABLE TABLES / TABLES EXTENSIBLES / AUSZIEHBARE TISCHE / MESAS EXTENSIBLES

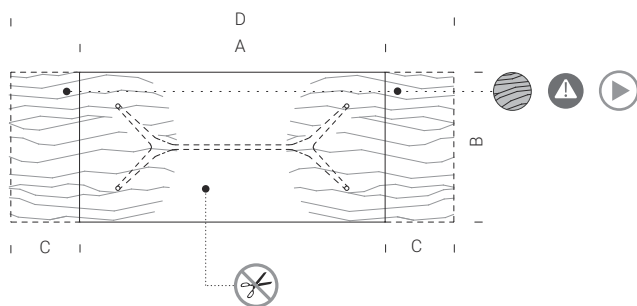
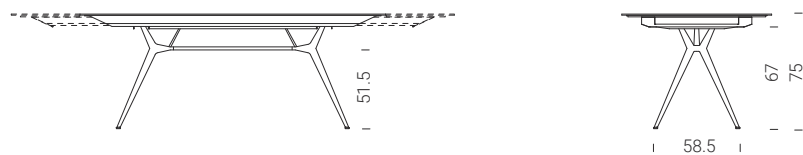

	A / D x B	C		S05 S06 S07 S08	L03 L06	L08 L10 L11	Y36 Y34 Y37 Y39 Y40
GTAV0083	170 / 260 x 90	45+45	6 (10)	4299	3806	4072	4320
GTAV0086	170 / 260 x 98	45+45	6 (10)	4389	3885	4157	4410
GTAV0084	200 / 290 x 90	45+45	8 (12)	4552	4029	4311	4574
GTAV0087	200 / 290 x 98	45+45	8 (12)	4666	4131	4420	4689
GTAV0085	230 / 320 x 90	45+45	10 (12)	4916	4351	4656	4939
GTAV0088	230 / 320 x 98	45+45	10 (12)	5037	4459	4771	5061

le allunghe possono essere posizionate all'interno del tavolo.
the extensions can be positioned inside the table.
les rallonges peuvent  tre plac es   l'int rieur de la table.
die Verl ngerungen k nnen innerhalb des Tisches gelegt werden.
las extensiones pueden colocarse dentro de la mesa.

impiallacciatura continua su top e allunghe
continues veneer on top and extensions
les veines du placage bois suivent sur les rallonges
sauberer Furnierverlauf  ber Tisch- und Verl ngerungsplatte
chapa de madera contin a en el plano y extensiones

top e allunghe nella stessa finitura
top and extensions with the same finish
plateau et rallonges dans la m me finition
Abdeck- und Ausziehplatten in derselben Vollendung
Encimera y extensiones en el mismo acabado

Apertura allunghe
Opening of extensions
Ouverture de rallonges
 ffnung verl ngerungsst cke
Apertura de la extension

acciaio verniciato/painted steel/acier peint
lackierter Stahl/acero pintado

- C12** bianco/white
- C21** seta/silk
- C23** corda/ecru
- C30** ghisa/cast-iron
- C14** antracite/anthracite
- C08** nero/black
- C18** verde/green
- C26** corten/corten
- C29** bronzo/bronze
- C37** rame/copper
- C38** titanio/titanium

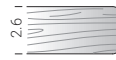

legno massiccio/solid wood
bois massif/Massivholz
madera maciza

- T01** rovere/oak
- T02** noce/walnut
- T03** iroko
- T04** iroko outdoor
- T05** rovere nero/black oak

ceramica/ceramic/c eramique
Keramik/cer mico

- S05** antracite/anthracite
- S06** nero/black
- S07** porfido/porfido
- S08** cardoso/cardoso

HPL POLARIS®

- L03** bianco/white
- L10** grigio chiaro/light grey
- L11** grigio scuro/dark grey

HPL FENIX®

- L08** grigio Londra/London grey
- L06** nero/black

HPL+ cemento/concrete/ciment
zement/cemento

- D01** bianco calce/lime white
- D02** grigio Portland/Portland grey
- D03** nero/black

HPL+ metallo/metal/m tal/Metall/metal

- C31** ottone/brass
- C32** ottone scuro/dark brass
- C35** inox/inox
- C36** inox scuro/dark inox

HPL+ legno/wood/bois/Holz/madera

- Y36** rovere/oak
- Y34** noce/walnut
- Y37** rovere affumicato/smoked oak
- Y39** frassino nero/black ash
- Y40** frassino argilla/clay ash

HPL+ ecotouch

- N01** sabbia/sand
- N02** basalto/basalt

TAVOLI RETTANGOLARI E QUADRATI / RECTANGULAR AND SQUARE TABLES / TABLES RECTANGULAIRES ET CARR ES
RECHTECKIGE UND QUADRATISCHE TISCHE / MESAS RECTANGULARES Y CUADRADAS

BALANCE

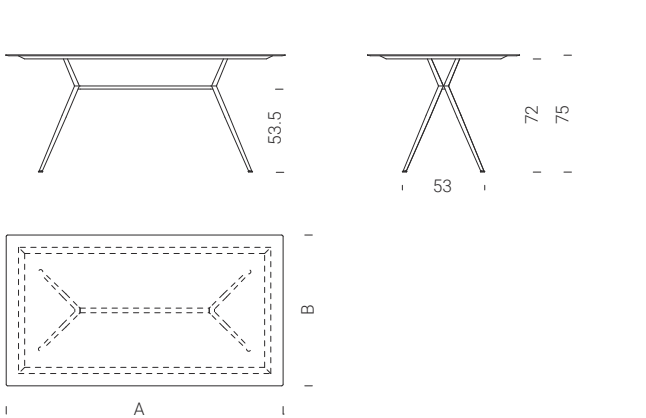

	A x B		T01 T03 T04	T02 T05	S05 S06	S07 S08	L03 L06	L08 L10 L11	D01 D02 D03	C31 C32 C35 C36	Y36 Y34 Y37 Y39 Y40	N01 N02		
GTAV0006	120 x 78	4	1653	1792	1721	1721	1508	1587	1749	2210	1727	1621	1000	+180
GTAV0025	160 x 78	6	2098	2153	1927	1927	1691	1791	1965	2584	1944	1794	1121	+180
GTAV0007	180 x 78	8	2237	2308	2071	2071	1798	1907	2088	2779	2067	1896	1192	+180
GTAV0008	120 x 90	6	1905	1932	1770	1770	1544	1633	1793	2324	1773	1646	1024	+180
GTAV0026	160 x 90	6	2231	2315	2084	2084	1813	1925	2106	2811	2086	1909	1202	+180
GTAV0009	180 x 90	8	2388	2493	2275	2275	2016	2139	2300	3090	2292	2079	1339	+180
GTAV0011	180 x 98	8	2501	2633	2330	2330	2026	2158	2354	3212	2334	2113	1343	+180

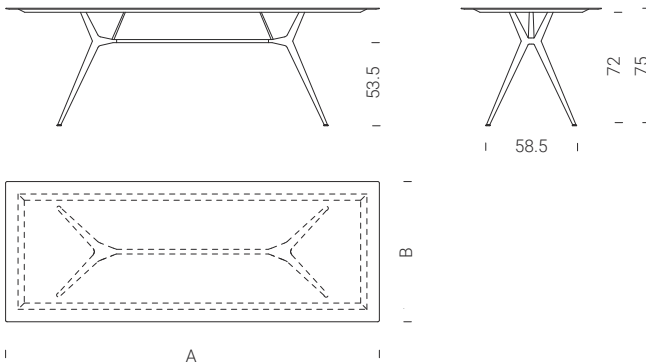

	A x B		T01 T03 T04	T02 T05	S05 S06	S07 S08	L03 L06	L08 L10 L11	D01 D02 D03	C31 C32 C35 C36	Y36 Y34 Y37 Y39 Y40	N01 N02		
GTAV0027	200 x 78	8	2369	2497	2237	2237	1941	2072	2267	3031	2245	2056	1244	+280
GTAV0028	200 x 90	8	2558	2702	2406	2406	2079	2225	2429	3298	2408	2185	1380	+280
GTAV0029	220 x 90	8	2754	2913	2533	2533	2217	2376	2590	3831	2569	2319	1421	+280
GTAV0010	240 x 90	10	2957	3378	2820	2820	2442	2613	2849	4192	2826	2554	1565	+280
GTAV0030	200 x 98	8	2575	2866	2523	2523	2183	2339	2550	3492	2529	2285	1399	+280
GTAV0031	220 x 98	8	2762	3083	2679	2679	2338	2508	2730	4077	2710	2435	1498	+280
GTAV0012	240 x 98	10	2965	3385	2968	2968	2573	2757	3002	4460	2980	2681	1650	+280
GTAV0032	300 x 98	12	3724	3942	3472	3472	3041	3261	3545	5359	3520	3145	1949	+280
GTAV0071	200 x 110	8	2832	3152	2775	2775	2401	2573	2805	3841	2782	2513	1539	+280
GTAV0072	220 x 110	8	3038	3391	2947	2947	2571	2759	3003	4484	2981	2679	1648	+280
GTAV0073	240 x 110	10	3213	3599	3265	3265	2831	3033	3303	4906	3277	2949	1815	+280
GTAV0074	300 x 110	8	4096	4336	3819	3819	3345	3587	3899	5895	3872	3460	2144	+280

maggiorazione per esterno riparato solo per surcharge for sheltered outdoor only for majoration pour ext rieur prot g  juste pour Zuschlag f r drau en gesch tzt nur f r aumento para exterior reparado solo para

T04 S05 D01 L03 L08 C35
S06 D02 L06 L10 C36
S07 D03 L11
S08

solo telaio (info pg.98)
frame only (info on pg.98)
seulement b ti (info pg.98)
Ausschlie lich Rahmen (Info pg.98)
solo marco (informaci n pg.98)

accessori disponibili a pg.112
accessories available on pg.112
accessoires disponibles pg. 112
erh ltliches Zubeh r auf pg.112
accesorios disponibles en pg.112

disponibili riduzioni a misura
tailor-made reduction available
disponibles r ductions sur mesure
Verkleinerung nach Kundenwunsch
disponibles reducciones a medida

GRID0005
+240  

- acciaio verniciato/painted steel/acier peint
lackierter Stahl/acero pintado
- C12 bianco/white
 - C21 seta/silk
 - C23 corda/ecru
 - C30 ghisa/cast-iron
 - C14 antracite/anthracite
 - C08 nero/black
 - C18 verde/green
 - C26 corten/corten
 - C29 bronzo/bronze
 - C37 rame/copper
 - C38 titanio/titanium

- legno massiccio/solid wood
bois massif/Massivholz
madera maciza
- T01 rovere/oak
 - T02 noce/walnut
 - T03 iroko
 - T04 iroko outdoor
 - T05 rovere nero/black oak

- ceramica/ceramic/c eramique
Keramik/cer mico
- S05 antracite/anthracite
 - S06 nero/black
 - S07 porfido/porfido
 - S08 cardoso/cardoso

- HPL POLARIS®
- L03 bianco/white
 - L10 grigio chiaro/light grey
 - L11 grigio scuro/dark grey
- HPL FENIX®
- L08 grigio Londra/London grey
 - L06 nero/black

- HPL+ cemento/concrete/ciment
zement/cemento
- D01 bianco calce/lime white
 - D02 grigio Portland/Portland grey
 - D03 nero/black
- HPL+ metallo/metal/m tal/Metall/metal
- C31 ottone/brass
 - C32 ottone scuro/dark brass
 - C35 inox/inox
 - C36 inox scuro/dark inox

- HPL+ legno/wood/bois/Holz/madera
- Y36 rovere/oak
 - Y34 noce/walnut
 - Y37 rovere affumicato/smoked oak
 - Y39 frassino nero/black ash
 - Y40 frassino argilla/clay ash
- HPL+ ecotouch
- N01 sabbia/sand
 - N02 basalto/basalt

TAVOLI A TESTA TONDA / ROUND HEAD TABLES / TABLES AUX EXTR MIT S ARRONDIES
RUNDER KOPF TISCHE / MESAS REDONDAS DE ESTRUCTURA LINEAL

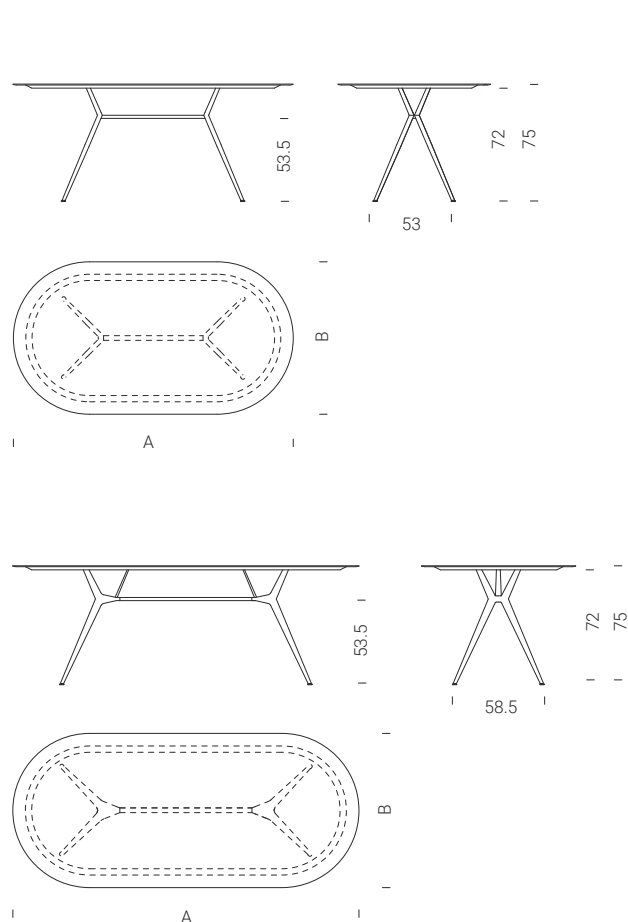

	A x B		T01 T03 T04	T02 T05	S05 S06	S07 S08	L03 L06	L08 L10 L11	D01 D02 D03	C31 C32 C35 C36	Y36 Y34 Y37 Y39 Y40	N01 N02		
GTAV0033	180 x 78	8	2237	2308	2071	2071	1798	1907	2088	2779	2067	1896	1192	+180
GTAV0034	180 x 90	8	2388	2493	2275	2275	2016	2139	2300	3090	2292	2079	1339	+180
GTAV0035	180 x 98	8	2501	2633	2330	2330	2026	2158	2354	3212	2334	2113	1343	+180

	A x B		T01 T03 T04	T02 T05	S05 S06	S07 S08	L03 L06	L08 L10 L11	D01 D02 D03	C31 C32 C35 C36	Y36 Y34 Y37 Y39 Y40	N01 N02		
GTAV0036	200 x 78	8	2369	2497	2237	2237	1941	2072	2267	3031	2245	2056	1244	+280
GTAV0037	200 x 90	8	2558	2702	2406	2406	2079	2225	2429	3298	2408	2185	1380	+280
GTAV0038	220 x 90	8	2754	2913	2533	2533	2217	2376	2590	3831	2569	2319	1421	+280
GTAV0039	240 x 90	10	2957	3378	2820	2820	2442	2613	2849	4192	2826	2554	1565	+280
GTAV0040	200 x 98	8	2575	2866	2523	2523	2183	2339	2550	3492	2529	2285	1399	+280
GTAV0041	220 x 98	8	2762	3083	2679	2679	2338	2508	2730	4077	2710	2435	1498	+280
GTAV0042	240 x 98	10	2965	3385	2968	2968	2573	2757	3002	4460	2980	2681	1650	+280
GTAV0043	300 x 98	12	3724	3942	3472	3472	3041	3261	3545	5359	3520	3145	1949	+280

maggiorazione per esterno riparato solo per surcharge for sheltered outdoor only for majoration pour ext rieur prot g  juste pour Zuschlag f r drau en gesch tzt nur f r aumento para exterior reparado solo para

T04 S05 D01 L03 L08 C35
S06 D02 L06 L10 C36
S07 D03 L11
S08

solo telaio (info pg.98)
frame only (info on pg.98)
seulement b ti (info pg.98)
Ausschlie lich Rahmen (Info pg.98)
solo marco (informaci n pg.98)

accessori disponibili a pg.112
accessories available on pg.112
accessoires disponibles pg.112
erh ltliches Zubeh r auf pg.112
accesorios disponibles en pg.112

disponibili riduzioni a misura
tailor-made reduction available
disponibles r ductions sur mesure
Verkleinerung nach Kundenwunsch
disponibles reducciones a medida

GRID0005
+240  

acciaio verniciato/painted steel/acier peint
lackierter Stahl/acero pintado

- C12** bianco/white
- C21** seta/silk
- C23** corda/ecru
- C30** ghisa/cast-iron
- C14** antracite/anthracite
- C08** nero/black
- C18** verde/green
- C26** corten/corten
- C29** bronzo/bronze
- C37** rame/copper
- C38** titanio/titanium

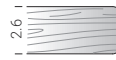

legno massiccio/solid wood
bois massif/Massivholz
madera maciza
T01 rovere/oak
T02 noce/walnut
T03 iroko
T04 iroko outdoor
T05 rovere nero/black oak

ceramica/ceramic/c eramique
Keramik/cer mico
S05 antracite/anthracite
S06 nero/black
S07 porfido/porfido
S08 cardoso/cardoso

HPL POLARIS®
L03 bianco/white
L10 grigio chiaro/light grey
L11 grigio scuro/dark grey
HPL FENIX®
L08 grigio Londra/London grey
L06 nero/black

HPL+ cemento/concrete/ciment
zement/cemento
D01 bianco calce/lime white
D02 grigio Portland/Portland grey
D03 nero/black
HPL+ metallo/metal/m tal/Metall/metal
C31 ottone/brass
C32 ottone scuro/dark brass
C35 inox/inox
C36 inox scuro/dark inox

HPL+ legno/wood/bois/Holz/madera
Y36 rovere/oak
Y34 noce/walnut
Y37 rovere affumicato/smoked oak
Y39 frassino nero/black ash
Y40 frassino argilla/clay ash
HPL+ ecotouch
N01 sabbia/sand
N02 basalto/basalt

TAVOLI A BOTTE / BARREL VAULT TABLES / TABLES TONNEAU
WEINFASS-TISCHE / MESAS DE BARRIL

BALANCE

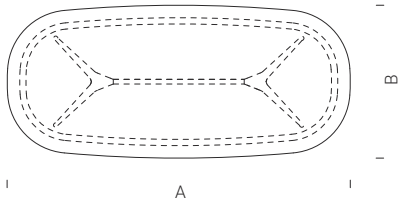
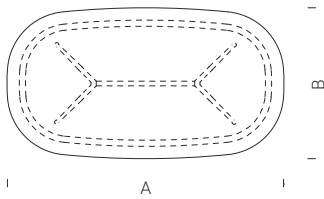
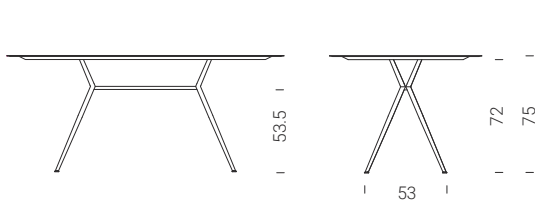

	A x B		T01 T03 T04	T02 T05	S05 S06	S07 S08	L03 L06	L08 L10 L11	D01 D02 D03	C31 C32 C35 C36	Y36 Y34 Y37 Y39 Y40	N01 N02		
GTAV0044	180 x 98	8	2501	2633	2330	2330	2026	2158	2354	3212	2334	2113	1343	+180
GTAV0045	180 x 105	8	2662	2962	2608	2608	2256	2418	2636	3610	2615	2362	1446	+180

	A x B		T01 T03 T04	T02 T05	S05 S06	S07 S08	L03 L06	L08 L10 L11	D01 D02 D03	C31 C32 C35 C36	Y36 Y34 Y37 Y39 Y40	N01 N02		
GTAV0046	200 x 98	8	2575	2866	2523	2523	2183	2339	2550	3492	2529	2285	1399	+280
GTAV0047	220 x 98	8	2762	3083	2679	2679	2338	2508	2730	4077	2710	2435	1498	+280
GTAV0048	240 x 98	10	2965	3385	2968	2968	2573	2757	3002	4460	2980	2681	1650	+280
GTAV0049	300 x 98	12	3724	3942	3472	3472	3041	3261	3545	5359	3520	3145	1949	+280
GTAV0050	200 x 105	8	2832	3152	2775	2775	2401	2573	2805	3841	2782	2513	1539	+280
GTAV0051	220 x 105	8	3038	3391	2947	2947	2571	2759	3003	4484	2981	2679	1648	+280
GTAV0052	240 x 105	10	3213	3599	3265	3265	2831	3033	3303	4906	3277	2949	1815	+280
GTAV0053	300 x 105	12	4096	4336	3819	3819	3345	3587	3899	5895	3872	3460	2144	+280

maggiorazione per esterno riparato solo per surcharge for sheltered outdoor only for majoration pour ext rieur prot g  juste pour Zuschlag f r drau en gesch tzt nur f r aumento para exterior reparado solo para

T04 S05 D01 L03 L08 C35
S06 D02 L06 L10 C36
S07 D03 L11
S08

solo telaio (info pg.98)
frame only (info on pg.98)
seulement b ti (info pg.98)
Ausschlie lich Rahmen (Info pg.98)
solo marco (informaci n pg.98)

accessori disponibili a pg.112
accessories available on pg.112
accessoires disponibles pg.112
erh ltliches Zubeh r auf pg.112
accesorios disponibles en pg.112

disponibili riduzioni a misura
tailor-made reduction available
disponibles r ductions sur mesure
Verkleinerung nach Kundenwunsch
disponibles reducciones a medida

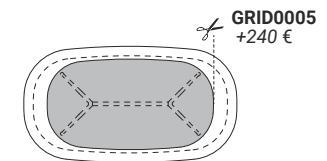

- acciaio verniciato/painted steel/acier peint
lackierter Stahl/acero pintado
- C12** bianco/white
 - C21** seta/silk
 - C23** corda/ecru
 - C30** ghisa/cast-iron
 - C14** antracite/anthracite
 - C08** nero/black
 - C18** verde/green
 - C26** corten/corten
 - C29** bronzo/bronze
 - C37** rame/copper
 - C38** titanio/titanium

- legno massiccio/solid wood
bois massif/Massivholz
madera maciza
- T01** rovere/oak
 - T02** noce/walnut
 - T03** iroko
 - T04** iroko outdoor
 - T05** rovere nero/black oak

- ceramica/ceramic/c ramique
Keramik/cer mico
- S05** antracite/anthracite
 - S06** nero/black
 - S07** porfido/porfido
 - S08** cardoso/cardoso

- HPL POLARIS®
- L03** bianco/white
 - L10** grigio chiaro/light grey
 - L11** grigio scuro/dark grey
- HPL FENIX®
- L08** grigio Londra/London grey
 - L06** nero/black

- HPL+ cemento/concrete/ciment
zement/cemento
- D01** bianco calce/lime white
 - D02** grigio Portland/Portland grey
 - D03** nero/black
- HPL+ metallo/metal/m tal/Metall/metal
- C31** ottone/brass
 - C32** ottone scuro/dark brass
 - C35** inox/inox
 - C36** inox scuro/dark inox

- HPL+ legno/wood/bois/Holz/madera
- Y36** rovere/oak
 - Y34** noce/walnut
 - Y37** rovere affumicato/smoked oak
 - Y39** frassino nero/black ash
 - Y40** frassino argilla/clay ash
- HPL+ ecotouch
- N01** sabbia/sand
 - N02** basalto/basalt

TAVOLI OVALI / OVAL TABLES / TABLES OVALES OVALTISCHE / MESAS OVALADAS

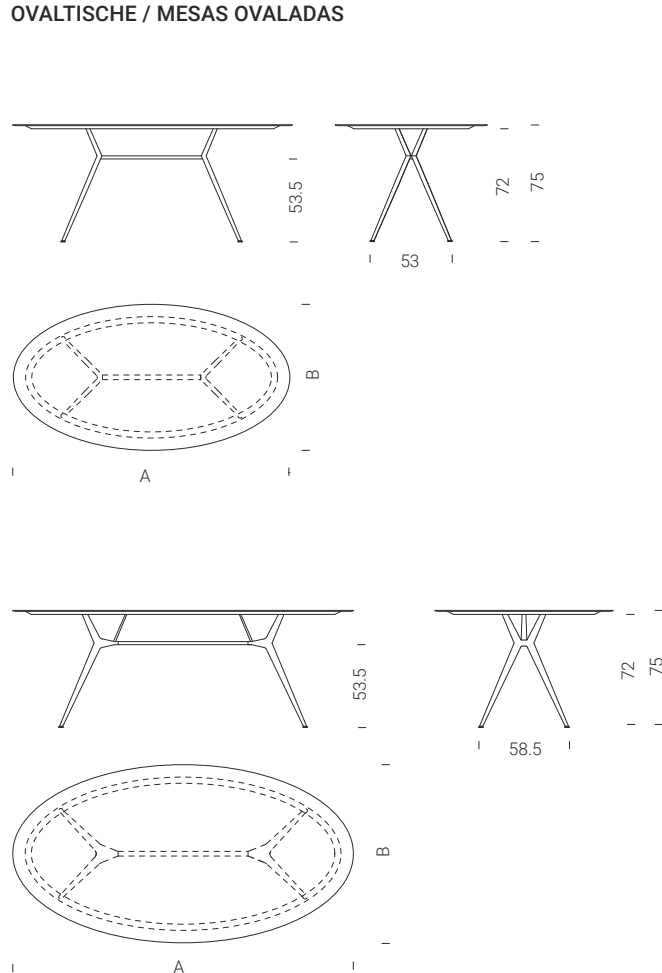

	A x B		T01 T03 T04	T02 T05	S05 S06	S07 S08	L03 L06	L08 L10 L11	D01 D02 D03	C31 C32 C35 C36	Y36 Y34 Y37 Y39 Y40	N01 N02		
GTAV0054	160 x 85	6	2134	2222	2044	2044	1712	1819	1990	2643	1971	1804	1098	+180
GTAV0055	180 x 95	8	2464	2574	2321	2321	1954	2084	2210	3096	2254	2039	1253	+180

	A x B		T01 T03 T04	T02 T05	S05 S06	S07 S08	L03 L06	L08 L10 L11	D01 D02 D03	C31 C32 C35 C36	Y36 Y34 Y37 Y39 Y40	N01 N02		
GTAV0056	200 x 105	8	2756	3069	2658	2658	2232	2398	2609	3907	2590	2322	1431	+280
GTAV0057	220 x 115	8	3151	3528	3023	3023	2546	2741	2973	4530	2955	2627	1632	+280
GTAV0058	248 x 128	10	3330	3823	3250	-	3073	3309	-	-	3565	3150	1970	+280

maggiorazione per esterno riparato solo per surcharge for sheltered outdoor only for majoration pour ext rieur prot g e juste pour Zuschlag f r drau en gesch tzt nur f r aumento para exterior reparado solo para

T04 S05 D01 L03 L08 C35
S06 D02 L06 L10 C36
S07 D03 L11
S08

solo telaio (info pg.98)
frame only (info on pg.98)
seulement b ti (info pg.98)
Ausschlie lich Rahmen (Info pg.98)
solo marco (informaci n pg.98)

accessori disponibili a pg.112
accessories available on pg.112
accessoires disponibles pg.112
erh ltliches Zubeh r auf pg.112
accesorios disponibles en pg.112

disponibili riduzioni a misura
tailor-made reduction available
disponibles r ductions sur mesure
Verkleinerung nach Kundenwunsch
disponibles reducciones a medida

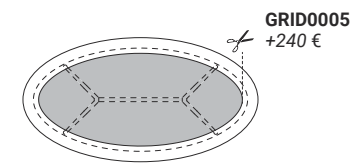

acciaio verniciato/painted steel/acier peint
lackierter Stahl/acero pintado

- C12 bianco/white
- C21 seta/silk
- C23 corda/ecru
- C30 ghisa/cast-iron
- C14 antracite/anthracite
- C08 nero/black
- C18 verde/green
- C26 corten/corten
- C29 bronzo/bronze
- C37 rame/copper
- C38 titanio/titanium

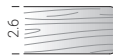

legno massiccio/solid wood
bois massif/Massivholz
madera maciza

- T01 rovere/oak
- T02 noce/walnut
- T03 iroko
- T04 iroko outdoor
- T05 rovere nero/black oak



ceramica/ceramic/c eramique
Keramik/cer mico

- S05 antracite/anthracite
- S06 nero/black
- S07 porfido/porfido
- S08 cardoso/cardoso



HPL POLARIS®

- L03 bianco/white
- L10 grigio chiaro/light grey
- L11 grigio scuro/dark grey

HPL FENIX®

- L08 grigio Londra/London grey
- L06 nero/black



HPL+ cemento/concrete/ciment
zement/cemento

- D01 bianco calce/lime white
- D02 grigio Portland/Portland grey
- D03 nero/black

HPL+ metallo/metal/m tal/Metall/metal

- C31 ottone/brass
- C32 ottone scuro/dark brass
- C35 inox/inox
- C36 inox scuro/dark inox



HPL+ legno/wood/bois/Holz/madera

- Y36 rovere/oak
- Y34 noce/walnut
- Y37 rovere affumicato/smoked oak
- Y39 frassino nero/black ash
- Y40 frassino argilla/clay ash

HPL+ ecotouch

- N01 sabbia/sand
- N02 basalto/basalt

TAVOLI TONDI / ROUND TABLES / TABLES RONDES
RUNDTISCHE TISCHE / MESAS REDONDAS

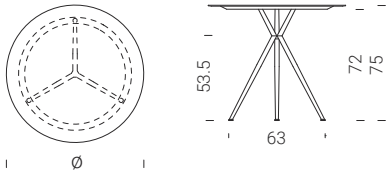

	∅		T01 T03 T04	T02 T05	S05 S06	S07 S08	L03 L06	L08 L10 L11	D01 D02 D03	C31 C32 C35 C36	Y36 Y34 Y37 Y39 Y40	N01 N02		
GTAV0019	90	3	1396	1503	1403	1403	1185	1237	1359	1750	1344	1249	760	+180

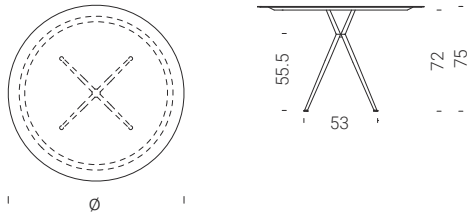

	∅		T01 T03 T04	T02 T05	S05 S06	S07 S08	L03 L06	L08 L10 L11	D01 D02 D03	C31 C32 C35 C36	Y36 Y34 Y37 Y39 Y40	N01 N02		
GTAV0023	110	5	1973	2153	1959	1959	1680	1758	1929	2667	1908	1763	1077	+180
GTAV0024	128	6	2343	2587	2220	-	1931	2068	-	-	2239	2034	1238	+180

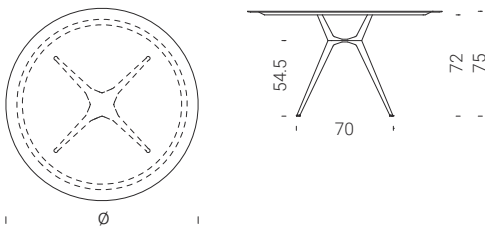

	∅		T01 T03 T04	T02 T05	S05 S06	S07 S08	L03 L06	L08 L10 L11	D01 D02 D03	C31 C32 C35 C36	Y36 Y34 Y37 Y39 Y40	N01 N02		
GTAV0021	140	7	2774	2908	2429	-	2113	2247	-	-	2427	2176	1354	+280
GTAV0022	160	8	3036	3280	2849	-	2478	2643	-	-	2847	2512	1589	+280



maggiorazione per esterno riparato solo per surcharge for sheltered outdoor only for majoration pour ext rieur prot g  juste pour Zuschlag f r drau en gesch tzt nur f r aumento para exterior reparado solo para

T04 S05 D01 L03 L08 C35
S06 D02 L06 L10 C36
S07 D03 L11
S08



solo telaio (info pg.98)
frame only (info on pg.98)
seulement b ti (info pg.98)
Ausschlie lich Rahmen (Info pg.98)
solo marco (informaci n pg.98)



accessori disponibili a pg.112
accessories available on pg.112
accessoires disponibles pg.112
seulement b ti (info pg.98)
erh ltliches Zubeh r auf pg.112
accesorios disponibles en pg.112



disponibili riduzioni a misura
tailor-made reduction available
disponibles r ductions sur mesure
Verkleinerung nach Kundenwunsch
disponibles reducciones a medida

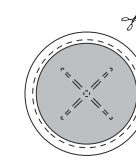

GRID0005
+240  

- acciaio verniciato/painted steel/acier peint
lackierter Stahl/acero pintado
- C12** bianco/white
 - C21** seta/silk
 - C23** corda/ecru
 - C30** ghisa/cast-iron
 - C14** antracite/anthracite
 - C08** nero/black
 - C18** verde/green
 - C26** corten/corten
 - C29** bronzo/bronze
 - C37** rame/copper
 - C38** titanio/titanium

- legno massiccio/solid wood
bois massif/Massivholz
madera maciza
- T01** rovere/oak
 - T02** noce/walnut
 - T03** iroko
 - T04** iroko outdoor
 - T05** rovere nero/black oak

- ceramica/ceramic/c eramique
Keramik/cer amico
- S05** antracite/anthracite
 - S06** nero/black
 - S07** porfido/porfido
 - S08** cardoso/cardoso

- HPL POLARIS®
- L03** bianco/white
 - L10** grigio chiaro/light grey
 - L11** grigio scuro/dark grey
- HPL FENIX®
- L08** grigio Londra/London grey
 - L06** nero/black

- HPL+ cemento/concrete/ciment
zement/cemento
- D01** bianco calce/lime white
 - D02** grigio Portland/Portland grey
 - D03** nero/black
- HPL+ metallo/metal/m etal/Metall/metal
- C31** ottone/brass
 - C32** ottone scuro/dark brass
 - C35** inox/inox
 - C36** inox scuro/dark inox

- HPL+ legno/wood/bois/Holz/madera
- Y36** rovere/oak
 - Y34** noce/walnut
 - Y37** rovere affumicato/smoked oak
 - Y39** frassino nero/black ash
 - Y40** frassino argilla/clay ash
- HPL+ ecotouch
- N01** sabbia/sand
 - N02** basalto/basalt

TAVOLI QUADRATI / SQUARE TABLES / TABLES CARR ES / QUADRATISCHE TISCHE / MESAS CUADRADAS

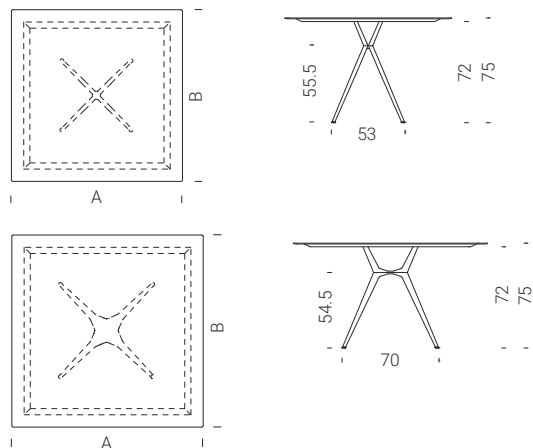

	A x B		T01 T03 T04	T02 T05	S05 S06	S07 S08	L03 L06	L08 L10 L11	D01 D02 D03	C31 C32 C35 C36	Y36 Y34 Y37 Y39 Y40	N01 N02		
GTAV0077	78 x 78	2	1490	1580	1452	1452	1281	1334	1477	1765	1456	1394	821	+180
GTAV0078	90 x 90	4	1521	1589	1626	1626	1425	1495	1649	2033	1628	1539	913	+180
GTAV0079	98 x 98	4	1896	1979	1737	1737	1511	1598	1759	2214	1737	1628	1002	+180
GTAV0080	120 x 120	6	2395	2522	2235	2235	1940	2067	2254	3076	2236	2023	1426	+180
	A x B													
GTAV0081	140 x 140	8	2697	2850	2521	-	2193	2390	-	-	2580	2291	1506	+280

TAVOLI QUADRATI A BOTTE / SQUARE BARREL TABLES / TABLES   TONNEAU CARR ES VIERECKIGE TONNENF ORMIGE TISCHE / MESAS CUADRADAS

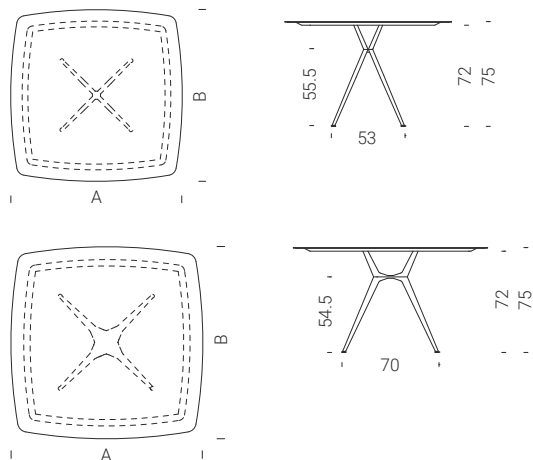

	A x B		T01 T03 T04	T02 T05	S05 S06	S07 S08	L03 L06	L08 L10 L11	D01 D02 D03	C31 C32 C35 C36	Y36 Y34 Y37 Y39 Y40	N01 N02		
GTAV0094	78 x 78	2	1490	1580	1452	1452	1281	1334	1477	1765	1456	1394	821	+180
GTAV0095	90 x 90	4	1521	1589	1626	1626	1425	1495	1649	2033	1628	1539	913	+180
GTAV0096	98 x 98	4	1896	1979	1737	1737	1511	1598	1759	2214	1737	1628	1002	+180
GTAV0075	120 x 120	6	2395	2522	2235	2235	1940	2067	2254	3076	2236	2023	1426	+180
	A x B													
GTAV0076	140 x 140	8	2697	2850	2521	-	2193	2390	-	-	2580	2291	1506	+280

maggiorazione per esterno riparato solo per surcharge for sheltered outdoor only for majoration pour ext rieur prot g e juste pour Zuschlag f r drau en gesch tzt nur f r aumento para exterior reparado solo para

**T04 S05 D01 L03 L08 C35
S06 D02 L06 L10 C36
S07 D03 L11
S08**

solo telaio (info pg.98)
frame only (info on pg.98)
seulement b ti (info pg.98)
Ausschlie lich Rahmen (Info pg.98)
solo marco (informaci n pg.98)

accessori disponibili a pg.112
accessories available on pg.112
accessoires disponibles pg.112
erh ltliches Zubeh r auf pg.112
accesorios disponibles en pg.112

disponibili riduzioni a misura
tailor-made reduction available
disponibles r ductions sur mesure
Verkleinerung nach Kundenwunsch
disponibles reducciones a medida

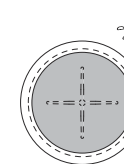

GRID0005
+240  

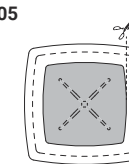

GRID0005
+240  

acciaio verniciato/painted steel/acier peint
lackierter Stahl/acero pintado

- C12** bianco/white
- C21** seta/silk
- C23** corda/ecru
- C30** ghisa/cast-iron
- C14** antracite/anthracite
- C08** nero/black
- C18** verde/green
- C26** corten/corten
- C29** bronzo/bronze
- C37** rame/copper
- C38** titanio/titanium

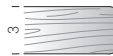

legno massiccio/solid wood
bois massif/Massivholz
madera maciza

- T01** rovere/oak
- T02** noce/walnut
- T03** iroko
- T04** iroko outdoor
- T05** rovere nero/black oak

ceramica/ceramic/c eramique
Keramik/cer mico

- S05** antracite/anthracite
- S06** nero/black
- S07** porfido/porfido
- S08** cardoso/cardoso

HPL POLARIS®

- L03** bianco/white
- L10** grigio chiaro/light grey
- L11** grigio scuro/dark grey

HPL FENIX®

- L08** grigio Londra/London grey
- L06** nero/black

HPL+ cemento/concrete/ciment
zement/cemento

- D01** bianco calce/lime white
- D02** grigio Portland/Portland grey
- D03** nero/black

HPL+ metallo/metal/m tal/Metall/metal

- C31** ottone/brass
- C32** ottone scuro/dark brass
- C35** inox/inox
- C36** inox scuro/dark inox

HPL+ legno/wood/bois/Holz/madera

- Y36** rovere/oak
- Y34** noce/walnut
- Y37** rovere affumicato/smoked oak
- Y39** frassino nero/black ash
- Y40** frassino argilla/clay ash

HPL+ ecotouch

- N01** sabbia/sand
- N02** basalto/basalt

TAVOLI DOGATI / SLATTED TABLES / TABLES   LATTES / DAUBEN-TISCHE / MESAS LAMINADAS

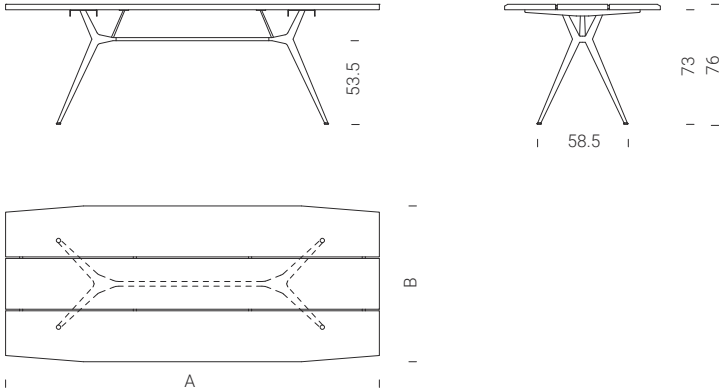

	A x B		T01 T03	T02 T05		T04
GTAV0089	180 x 100	6	3595	3949		3775
GTAV0092	240 x 100	10	4262	5077		4542
GTAV0093	300 x 100	12	5353	5913		5633

SCRITTOI / WRITING DESKS / SECR TAIRES / SCHREIBTISCHEN / ESCRITORIOS

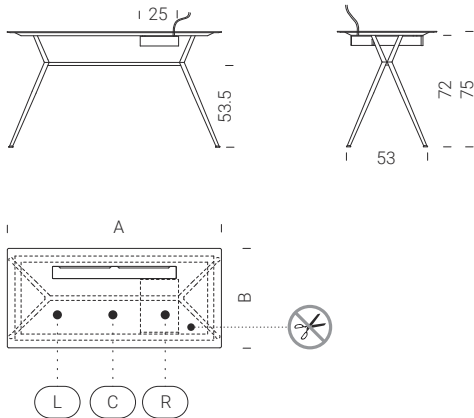

	A x B	(C) (D)	S05 S06	S07 S08	L03 L06	L08 L10 L11	D01 D02 D03	C31 C32 C35 C36	Y36 Y34 Y37 Y39 Y40	N01 N02
GTAV0059	100 x 65	(47) (28)	1868	1868	1607	1666	1855	2253	1825	1762
GTAV0060	120 x 65	(47) (28)	2111	2111	1867	1940	2039	2494	2007	1924
GTAV0013	140 x 65	(47) (28)	2290	2290	1904	1990	2210	2741	2176	2076
GTAV0014	160 x 65	(47) (28)	2421	2421	2014	2111	2341	2938	2307	2189
GTAV0015	160 x 78	(53) (34)	2588	2588	2157	2272	2512	3208	2478	2332

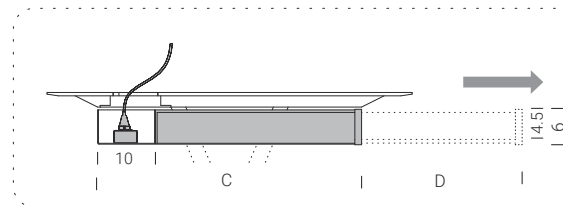

cassetto in acciaio e frontale nelle finiture del tavolo.
steel drawer and front in the table finishings.
tiroir en acier et fa ade dans les m mes finitions que la table.
Stahlschublade und Vorderseite in den Tischausf hrungen.
caj n de acero y frontal en los acabados de la mesa.

esterno **T04**
outdoor **T04**
ext rieur **T04**
drau en **T04**
exterior **T04**

disponibili riduzioni a misura
tailor-made reduction available
disponibles r ductions sur mesure
Verkleinerung nach Kundenwunsch
disponibles reducciones a medida

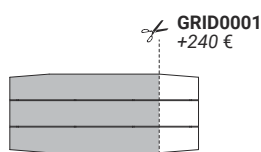

ordinabile in posizione C (centrale).
available in the following positions: C (central).
peut  tre command  en position C (centrale).
aufstellbar in Position C (Mitte).
disponible en posici n C (central).

ordinabile in posizione L (sinistra), C (centrale), R (destra).
available in the following positions: L (left), C (central), R (right).
peut  tre command  en position L (gauche), C (centrale), R (droite).
aufstellbar in Position L (links), C (Mitte), R (rechts).
disponible en posici n L (izquierda), C (central), R (derecha).

- acciaio verniciato/painted steel/acier peint
lackierter Stahl/acero pintado
- C12** bianco/white
 - C21** seta/silk
 - C23** corda/ecru
 - C30** ghisa/cast-iron
 - C14** antracite/anthracite
 - C08** nero/black
 - C18** verde/green
 - C26** corten/corten
 - C29** bronzo/bronze
 - C37** rame/copper
 - C38** titanio/titanium

- ceramica/ceramic/c ramique
Keramik/cer mico
- S05** antracite/anthracite
 - S06** nero/black
 - S07** porfido/porfido
 - S08** cardoso/cardoso

- HPL POLARIS®
- L03** bianco/white
 - L10** grigio chiaro/light grey
 - L11** grigio scuro/dark grey
- HPL FENIX®
- L08** grigio Londra/London grey
 - L06** nero/black

- HPL+ cemento/concrete/ciment
zement/cemento
- D01** bianco calce/lime white
 - D02** grigio Portland/Portland grey
 - D03** nero/black
- HPL+ metallo/metal/m tal/Metall/metal
- C31** ottone/brass
 - C32** ottone scuro/dark brass
 - C35** inox/inox
 - C36** inox scuro/dark inox

- HPL+ legno/wood/bois/Holz/madera
- Y36** rovere/oak
 - Y34** noce/walnut
 - Y37** rovere affumicato/smoked oak
 - Y39** frassino nero/black ash
 - Y40** frassino argilla/clay ash
- HPL+ ecotouch
- N01** sabbia/sand
 - N02** basalto/basalt

TAVOLI H 95 CM / TABLES H 95 CM / TABLES H 95 CM / TISCHE H 95 CM / MESAS H 95 CM

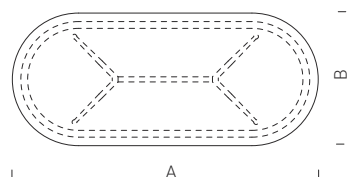
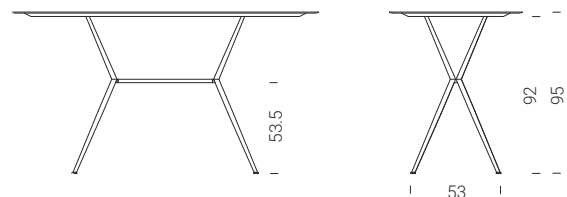
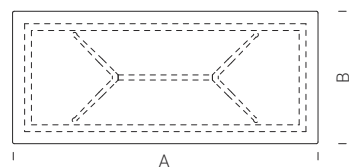
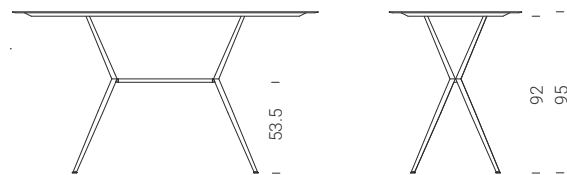

	A x B		S05 S06	S07 S08	L03 L06	L08 L10 L11	D01 D02 D03	C31 C32 C35 C36	Y36 Y34 Y37 Y39 Y40	N01 N02		
GTAV0061	120 x 78	4	1721	1721	1508	1587	1749	2210	1727	1621	1000	+180
GTAV0062	160 x 78	6	1927	1927	1691	1791	1965	2584	1944	1794	1121	+180
GTAV0063	180 x 78	8	2071	2071	1798	1907	2088	2779	2067	1896	1192	+180
GTAV0064	120 x 90	6	1770	1770	1544	1633	1793	2324	1773	1646	1024	+180
GTAV0065	160 x 90	6	2084	2084	1813	1925	2106	2811	2086	1909	1202	+180
GTAV0066	180 x 90	8	2275	2275	2016	2139	2300	3090	2292	2079	1339	+180
GTAV0067	180 x 98	8	2330	2330	2026	2158	2354	3212	2334	2113	1343	+180

	A x B		S05 S06	S07 S08	L03 L06	L08 L10 L11	D01 D02 D03	C31 C32 C35 C36	Y36 Y34 Y37 Y39 Y40	N01 N02		
GTAV0068	180 x 78	8	2071	2071	1798	1907	2088	2779	2067	1896	1192	+180
GTAV0069	180 x 90	8	2275	2275	2016	2139	2300	3090	2292	2079	1339	+180
GTAV0070	180 x 98	8	2330	2330	2026	2158	2354	3212	2334	2113	1343	+180

maggiorazione per esterno riparato solo per surcharge for sheltered outdoor only for majoration pour ext rieur prot g  juste pour Zuschlag f r drau en gesch tzt nur f r aumento para exterior reparado solo para

**T04 S05 D01 L03 L08 C35
S06 D02 L06 L10 C36
S07 D03 L11
S08**

solo telaio (info pg.98)
frame only (info on pg.98)
seulement b ti (info pg.98)
Ausschlie lich Rahmen (Info pg.98)
solo marco (informaci n pg.98)

accessori disponibili a pg.112
accessories available on pg.112
accessoires disponibles pg.112
erh ltliches Zubeh r auf pg.112
accesorios disponibles en pg.112

disponibili riduzioni a misura
tailor-made reduction available
disponibles r ductions sur mesure
Verkleinerung nach Kundenwunsch
disponibles reducciones a medida

GRID005
+240  

GRID005
+240  

PASSACAVO / CABLE GLAND / PASSE-CÂBLE / KABELDURCHLASS / PASACABLES

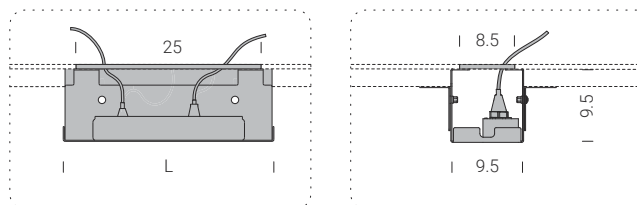
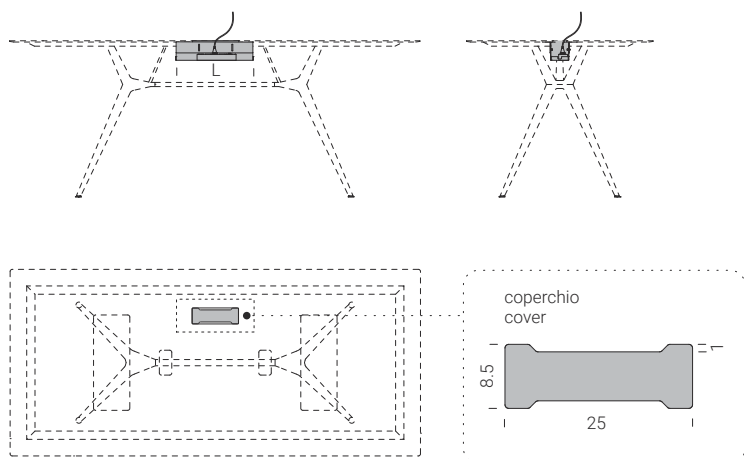

cesto in acciaio e copertura magnetica nelle finiture del tavolo.
steel basket and magnetic cover in the table finishings.
panier en acier et couvercle magnétique dans les mêmes finitions que la table.
Stahlkorb und Magnetabdeckung in der Tischausführung.
cesto de acero y cubierta magnética en los acabados de la mesa.

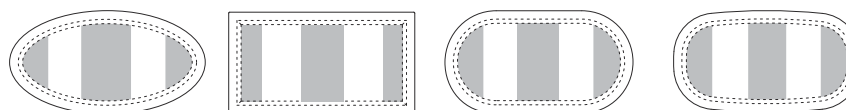

Il passacavi può essere posizionato esclusivamente nelle aree evidenziate.
the cable tidy can be placed only in the highlighted areas
le passe-câbles peut être placé que dans les domaines mis en évidence
das Kabeldurchführung kann nur in den hervorgehobenen Bereichen angeordnet werden
el pasacables se puede colocar sólo en las áreas resaltadas

	L	
SACC0003	28	185
SACC0004	40	205

vedi catalogo a pg.156
refer to catalogue pg.156
Voir catalogue pg. 156
siehe Katalog auf pg.156
véase pg.156 del catálogo

CASSETTO CON PASSACAVO / DRAWER WITH CABLE GLAND / TIROIR AVEC PASSE-CÂBLE / SCHUBLADE MIT KABELDURCHLASS / CAJÓN CON PASACABLES

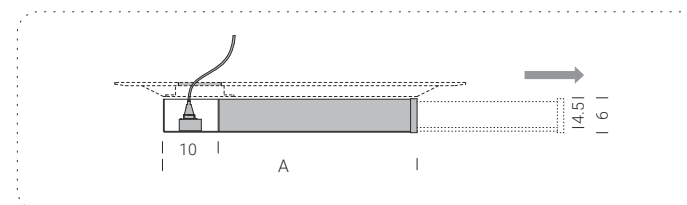
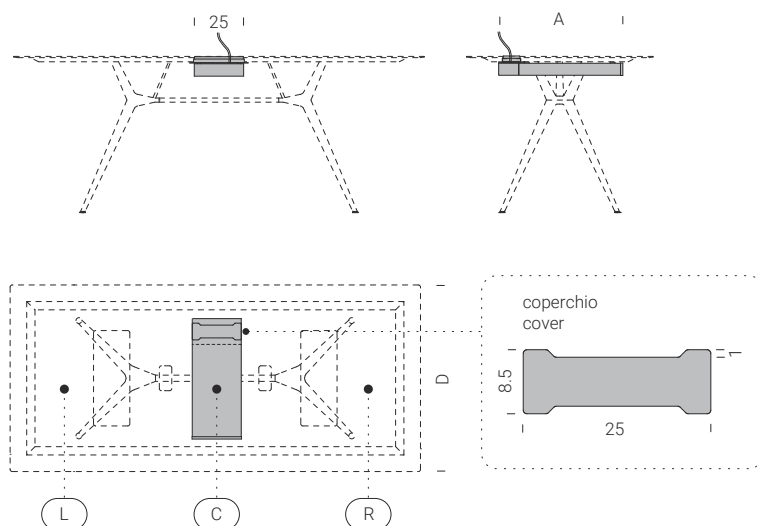

scozza in acciaio e frontale nelle finiture del tavolo. (il prezzo include la foratura del top tavolo).
Steel body and front in the table finishings. (the price includes perforation of the table top).
coque en acier et façade dans les mêmes finitions que la table. (le prix inclut le perçage du plateau de la table).
Stahlaufbau und Vorderseite in den Tischausführungen. (Die Bohrung der Tischplatte ist im Preis inbegriffen).
chapa de acero y frontal en los acabados de la mesa. (el precio incluye el perforado de la encimera).

ordinabile in posizione L (sinistra), R (destra), C (centrale).
available in the following positions: L (left), R (right), C (central).
peut être commandé en position L (gauche), R (droite), C (centrale).
aufstellbar in Position L (links), R (rechts), C (Mitte).
disponible en posición L (izquierda), R (derecha), C (central).

	A x B x C (D)	
GACC0001	47 x 25 x 6 (65)	260
GACC0002	53 x 25 x 6 (78)	280
GACC0003	68 x 25 x 6 (90)	320

vedi catalogo a pg.154 / refer to catalogue pg.154
Voir catalogue pg. 154 / siehe Katalog auf pg.154
véase pg.154 del catálogo



ceramica/ceramic/c ramique
Keramik/cer mico

- S05** antracite/anthracite
- S06** nero/black
- S07** porfido/porfido
- S08** cardoso/cardoso



HPL POLARIS®

- L03** bianco/white
- L10** grigio chiaro/light grey
- L11** grigio scuro/dark grey

HPL FENIX®

- L08** grigio Londra/London grey
- L06** nero/black



HPL+ cemento/concrete/ciment
zement/cemento

- D01** bianco calce/lime white
- D02** grigio Portland/Portland grey
- D03** nero/black

HPL+ metallo/metal/m tal/Metall/metal

- C31** ottone/brass
- C32** ottone scuro/dark brass
- C35** inox/inox
- C36** inox scuro/dark inox

CASSETTO / DRAWER / TIROIR / SCHUBLADE / CAJ N

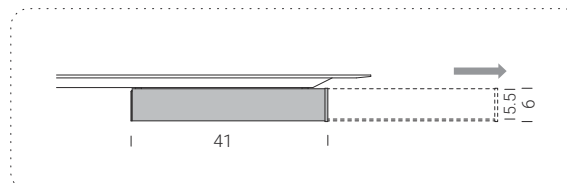
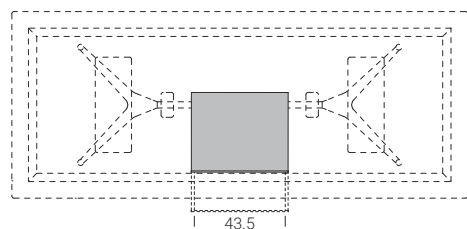
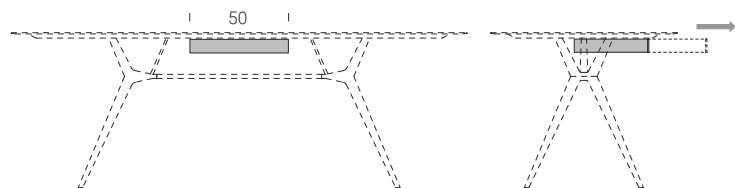

	A x B x C	
SACC0006	50 x 41 x 6	368

vedi catalogo a pg.206
refer to catalogue pg.206
Voir catalogue pg. 206
siehe Katalog auf pg.206
v ase pg.206 del cat logo

scocca in acciaio e frontale nelle finiture del tavolo.
Steel body and front in the table finishings.
coque en acier et fa ade dans les m mes finitions que la table.
Stahlaufbau und Vorderseite in den Tischausf hrungen.
chapa de acero y frontal en los acabados de la mesa.

⚠ disponibile per tavoli a partire da lunghezza 220 cm
available for tables starting from a length of 220 cm
disponible pour les tables   partir de 220 cm de longueur
verf gbar f r Tische ab einer L nge von 220 cm
disponible para mesas desde 220 cm de longitud

VASSOI / TRAYS / PLATEAUX / TABLETS / BANDEJAS

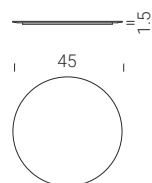

	S05	S06	S07	S08	L03	L06	L08	L10	L11	D01	D02	D03	C31	C32	C35	C36
SACC0007	45 x 1.5	190	165	180	205	245										

vedi catalogo a pg.172 / refer to catalogue pg.172
Voir catalogue pg. 172 / siehe Katalog auf pg.172
v ase pg.172 del cat logo

SPILLO



SPILLO È UN TAVOLO DAI MINIMI INGOMBRI VOLUMETRICI, IL TOP IN HPL HA UN BORDO PERIMETRALE VISIBILE DI SOLI 3MM. IL TELAIO IN ACCIAIO SOTTOSTANTE HA GEOMETRIE CHE MASSIMIZZANO LA RESISTENZA E LA RIGIDITÀ DEL TOP, CONSENTENDO LUNGHEZZE SINO A 250 CM. IL TELAIO ED I SUPPORTI A FORMA CONICA IN ACCIAIO COSTITUISCONO UN INSIEME DELLA MASSIMA LEGGEREZZA VOLUMETRICA.

The Spillo table offers minimum volume. The HPL top has a visible perimeter edge of just 3 mm. The underneath steel frame has geometries to maximise the strength and sturdiness of the top, allowing lengths up to 250 cm. The frame and the supports, which are made of steel and conical in shape, give an overall maximum volumetric lightness.

Spillo est une table présentant un encombrement volumétrique minimum, le plateau en HPL a un bord périphérique visible de 3mm seulement. La structure inférieure en acier présente des géométries qui augmentent au maximum la résistance et la rigidité du plateau, permettant des longueurs allant jusqu'à 250 cm. La structure et les supports de forme conique en acier constituent un ensemble de la plus grande légèreté volumétrique.

Spillo ist ein Tisch mit einem minimalem Platzbedarf, das Abschlussbord aus HPL hat eine sichtbare Kontourführung von nur 3 mm. Die Geometrien des darunter liegenden Rahmens aus Stahl maximieren die Widerstandsfähigkeit und Steifheit des Abschlussbords und ermöglichen somit Längen von bis zu 250 cm. Die Rahmen und konischen Stützen aus Stahl bilden eine Einheit mit maximaler, volumetrischer Leichtigkeit

Spillo es una mesa de dimensiones volumétricas mínimas. El sobre de HPL tiene un borde perimetral visible de solo 3 mm. El bastidor inferior de acero posee unas geometrías que maximizan la resistencia y la rigidez del sobre, permitiendo longitudes de hasta 250 cm. El bastidor y los soportes cónicos de acero componen un conjunto de máxima ligereza volumétrica.



Disponibili riduzioni a misura
Custom reductions available
Réductions sur mesure disponibles
Verkürzungen auf Maß erhältlich
Disponibles reducciones a medida



Passacavo disponibile per tutti i top
Cable gland available for all tops
Passe-câble disponible pour tous les plateaux
Kabeldurchlass für alle Abschlussborde verfügbar
Pasacables disponible para todos los sobres



Use in esterno riparato
Use in a sheltered outdoor space
Utilisation en extérieur, en espace abrité
Verwendung in geschütztem Außenbereich
Uso exterior protegido

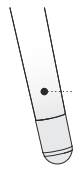

acciaio verniciato/painted steel/acier peint
lackierter Stahl/acero pintado

- C12** bianco/white
- C21** seta/silk
- C23** corda/ecru
- C30** ghisa/cast-iron
- C14** antracite/anthracite
- C08** nero/black
- C18** verde/green
- C26** corten/corten
- C29** bronzo/bronze
- C37** rame/copper
- C38** titanio/titanium



ceramica/ceramic/c eramique
Keramik/cer amico

- S05** antracite/anthracite
- S06** nero/black
- S07** porfido/porfido
- S08** cardoso/cardoso



HPL POLARIS®

- L03** bianco/white
- L10** grigio chiaro/light grey
- L11** grigio scuro/dark grey

HPL FENIX®

- L08** grigio Londra/London grey
- L06** nero/black



- HPL+ cemento/concrete/ciment
zement/cemento
- D01** bianco calce/lime white
- D02** grigio Portland/Portland grey
- D03** nero/black

HPL+ metallo/metal/m tal/Metall/metal

- C31** ottone/brass
- C32** ottone scuro/dark brass
- C35** inox/inox
- C36** inox scuro/dark inox



- HPL+ legno/wood/bois/Holz/madera
- Y36** rovere/oak
- Y34** noce/walnut
- Y37** rovere affumicato/smoked oak
- Y39** frassino nero/black ash
- Y40** frassino argilla/clay ash

HPL+ ecotouch

- N01** sabbia/sand
- N02** basalto/basalt

TAVOLI RETTANGOLARI E QUADRATI / RECTANGULAR AND SQUARE TABLES / TABLES RECTANGULAIRES ET CARR ES
RECHTECKIGE UND QUADRATISCHE TISCHE / MESAS RECTANGULARES Y CUADRADAS

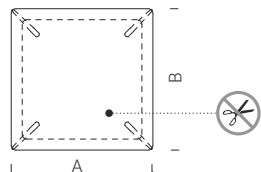
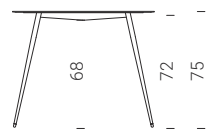
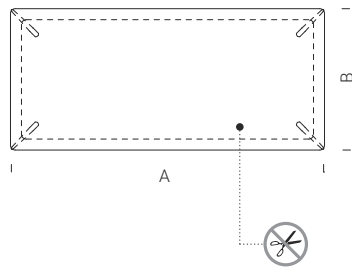
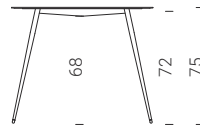
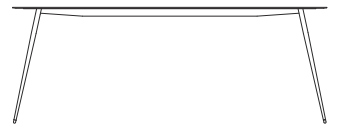

	A x B		S05 S06	S07 S08	L03 L06	L08 L10 L11	D01 D02 D03	C31 C32 C35 C36	Y36 Y34 Y37 Y39 Y40	N01 N02		
STAV0001	130 x 78	4	1733	1733	1520	1592	1755	2241	1740	1627	1082	+195
STAV0002	150 x 78	6	1939	1939	1701	1781	1964	2507	1946	1820	1235	+195
STAV0022	180 x 78	8	2131	2131	1869	1958	2158	2756	2139	2000	1341	+254
STAV0003	200 x 78	8	2281	2281	2001	2095	2310	2949	2289	2141	1433	+254
STAV0004	130 x 90	6	1865	1865	1636	1713	1889	2412	1872	1751	1147	+195
STAV0005	150 x 90	6	2048	2048	1796	1881	2074	2648	2055	1922	1305	+195
STAV0023	180 x 90	8	2252	2252	1975	2068	2281	2912	2260	2114	1422	+254
STAV0006	200 x 90	8	2553	2553	2239	2345	2585	3301	2562	2396	1529	+254
STAV0029	220 x 90	8	2801	2801	2457	2573	2836	3621	2811	2629	1596	+332
STAV0007	250 x 90	10	2920	2920	2561	2682	2957	3775	2930	2740	1739	+332
STAV0008	150 x 98	6	2115	2115	1855	1943	2142	2735	2123	1985	1356	+195
STAV0024	180 x 98	8	2321	2321	2048	2140	2349	2972	2329	2185	1474	+254
STAV0009	200 x 98	8	2598	2598	2291	2395	2630	3330	2607	2445	1574	+254
STAV0030	220 x 98	8	2930	2930	2571	2692	2968	3789	2941	2751	1661	+332
STAV0010	250 x 98	10	3238	3238	2841	2974	3280	4187	3250	3040	1828	+332

	A x B											
STAV0017	78 x 78	2	1342	1342	1177	1233	1359	1735	1347	1260	828	+195
STAV0018	90 x 90	4	1492	1492	1309	1371	1511	1930	1498	1401	909	+195
STAV0019	98 x 98	4	1588	1588	1393	1458	1608	2053	1593	1490	973	+195
STAV0063	120 x 120	6	2216	2216	1848	2025	2347	3130	2327	2176	1665	+220
STAV0020	140 x 140	8	2677	-	2343	2454	-	-	2820	2637	1846	+332



maggiorazione per esterno riparato solo per surcharge for sheltered outdoor only for majoration pour ext rieur prot g e juste pour Zuschlag f r drau en gesch tzt nur f r aumento para exterior reparado solo para

- S05** **D01** **L03** **L08** **C35**
- S06** **D02** **L06** **L10** **C36**
- S07** **D03** **L11**
- S08**



solo telaio (info pg.98)
frame only (info on pg.98)
seulement b ti (info pg.98)
Ausschlie lich Rahmen (Info pg.98)
solo marco (informaci n pg.98)



accessori disponibili a pg.119
accessories available on pg.119
accessoires disponibles pg.119
erh ltliches Zubeh r auf pg.119
accesorios disponibles en pg.119

acciaio verniciato/painted steel/acier peint
lackierter Stahl/acero pintado

- C12** bianco/white
- C21** seta/silk
- C23** corda/ecru
- C30** ghisa/cast-iron
- C14** antracite/anthracite
- C08** nero/black
- C18** verde/green
- C26** corten/corten
- C29** bronzo/bronze
- C37** rame/copper
- C38** titanio/titanium

ceramica/ceramic/c ramique
Keramik/cer mico

- S05** antracite/anthracite
- S06** nero/black
- S07** porfido/porfido
- S08** cardoso/cardoso

HPL POLARIS®

- L03** bianco/white
- L10** grigio chiaro/light grey
- L11** grigio scuro/dark grey

HPL FENIX®

- L08** grigio Londra/London grey
- L06** nero/black

HPL+ cemento/concrete/ciment
zement/cemento

- D01** bianco calce/lime white
- D02** grigio Portland/Portland grey
- D03** nero/black

HPL+ metallo/metal/m tal/Metall/metal

- C31** ottone/brass
- C32** ottone scuro/dark brass
- C35** inox/inox
- C36** inox scuro/dark inox

HPL+ legno/wood/bois/Holz/madera

- Y36** rovere/oak
- Y34** noce/walnut
- Y37** rovere affumicato/smoked oak
- Y39** frassino nero/black ash
- Y40** frassino argilla/clay ash

HPL+ ecotouch

- N01** sabbia/sand
- N02** basalto/basalt

TAVOLI A BOTTE / BARREL VAULT TABLES / TABLES TONNEAU WEINFASS-TISCHE / MESAS DE BARRIL

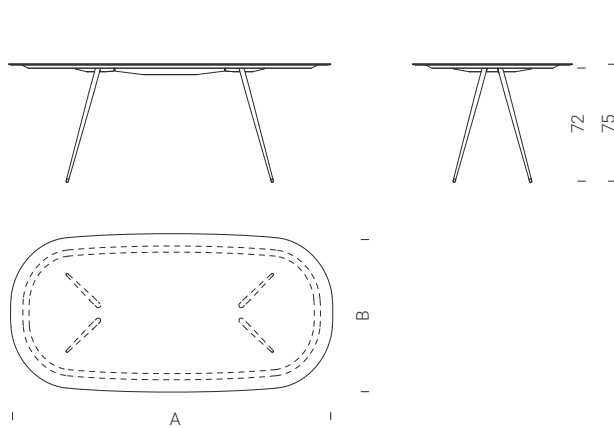

	A x B		S05 S06	S07 S08	L03 L06	L08 L10 L11	D01 D02 D03	C31 C32 C35 C36	Y36 Y34 Y37 Y39 Y40	N01 N02		
STAV0041	180 x 98	8	2467	2467	2164	2266	2627	3503	2603	2435	1519	+234
STAV0043	200 x 98	8	2566	2566	2251	2357	2732	3643	2708	2532	1615	+234
STAV0045	220 x 98	8	2895	2895	2539	2659	3082	4110	3055	2857	1783	+234
STAV0047	250 x 98	10	3051	3051	2677	2803	3249	4332	3220	3011	1981	+234
STAV0042	180 x 105	8	2493	2493	2187	2290	2655	3540	2631	2460	1579	+234
STAV0044	200 x 105	8	2598	2598	2279	2386	2766	3688	2741	2563	1675	+234
STAV0046	220 x 105	8	2963	2963	2599	2721	3154	4206	3126	2924	1842	+234
STAV0048	250 x 105	10	3072	3072	2695	2822	3271	4362	3242	3032	2041	+234

TAVOLI A TESTA TONDA / ROUND HEAD TABLES / TABLES AUX EXTR MIT S ARRONDIES RUNDER KOPF TISCHE / MESAS REDONDAS DE ESTRUCTURA LINEAL

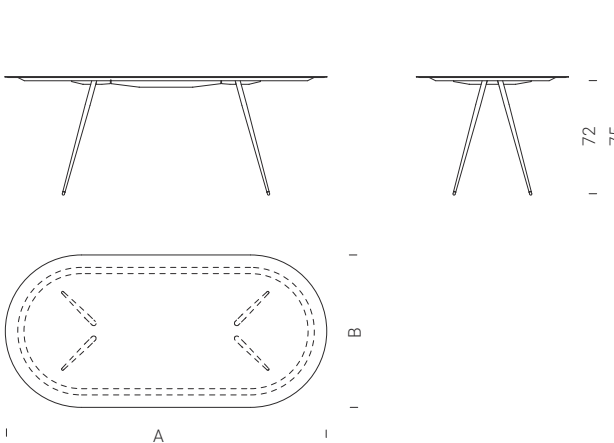

	A x B		S05 S06	S07 S08	L03 L06	L08 L10 L11	D01 D02 D03	C31 C32 C35 C36	Y36 Y34 Y37 Y39 Y40	N01 N02		
STAV0031	180 x 78	8	2196	2196	1926	2017	2338	3118	2317	2167	1399	+234
STAV0034	200 x 78	8	2285	2285	2004	2099	2432	3244	2411	2254	1495	+234
STAV0032	180 x 90	8	2393	2393	2087	2190	2555	3440	2531	2360	1459	+234
STAV0035	200 x 90	8	2446	2446	2146	2247	2605	3473	2581	2414	1555	+234
STAV0037	220 x 90	8	2608	2608	2288	2396	2777	3703	2752	2574	1723	+234
STAV0039	250 x 90	10	2879	2879	2526	2645	3066	4088	3038	2841	1921	+234
STAV0033	180 x 98	8	2467	2467	2164	2266	2627	3503	2603	2435	1519	+234
STAV0036	200 x 98	8	2566	2566	2251	2357	2732	3643	2708	2532	1615	+234
STAV0038	220 x 98	8	2895	2895	2539	2659	3082	4110	3055	2857	1783	+234
STAV0040	250 x 98	10	3051	3051	2677	2803	3249	4332	3220	3011	1981	+234

maggiorazione per esterno riparato solo per surcharge for sheltered outdoor only for majoration pour ext rieur prot g  juste pour Zuschlag f r drau en gesch tzt nur f r aumento para exterior reparado solo para

S05 D01 L03 L08 C35
S06 D02 L06 L10 C36
S07 D03 L11
S08

solo telaio (info pg.98)
frame only (info on pg.98)
seulement b ti (info pg.98)
Ausschlie lich Rahmen (Info pg.98)
solo marco (informaci n pg.98)

accessori disponibili a pg.119
accessories available on pg.119
accessoires disponibles pg.119
erh ltliches Zubeh r auf pg.119
accesorios disponibles en pg.119

disponibili riduzioni a misura
tailor-made reduction available
disponibles r ductions sur mesure
Verkleinerung nach Kundenwunsch
disponibles reducciones a medida

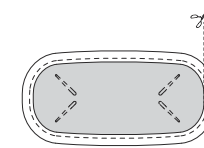

SRID0001
+240  

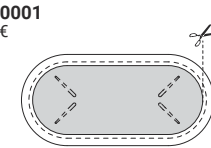

SRID0001
+240  



acciaio verniciato/painted steel/acier peint
lackierter Stahl/acero pintado

- C12** bianco/white
- C21** seta/silk
- C23** corda/ecru
- C30** ghisa/cast-iron
- C14** antracite/anthracite
- C08** nero/black
- C18** verde/green
- C26** corten/corten
- C29** bronzo/bronze
- C37** rame/copper
- C38** titanio/titanium



ceramica/ceramic/c eramique
Keramik/cer amico

- S05** antracite/anthracite
- S06** nero/black
- S07** porfido/porfido
- S08** cardoso/cardoso



HPL POLARIS®

- L03** bianco/white
- L10** grigio chiaro/light grey
- L11** grigio scuro/dark grey

HPL FENIX®

- L08** grigio Londra/London grey
- L06** nero/black



- HPL+ cemento/concrete/ciment
zement/cemento
- D01** bianco calce/lime white
- D02** grigio Portland/Portland grey
- D03** nero/black

HPL+ metallo/metal/m tal/Metall/metal

- C31** ottone/brass
- C32** ottone scuro/dark brass
- C35** inox/inox
- C36** inox scuro/dark inox



- HPL+ legno/wood/bois/Holz/madera
- Y36** rovere/oak
- Y34** noce/walnut
- Y37** rovere affumicato/smoked oak
- Y39** frassino nero/black ash
- Y40** frassino argilla/clay ash

HPL+ ecotouch

- N01** sabbia/sand
- N02** basalto/basalt

TAVOLI OVALI / OVAL TABLES / TABLES OVALES OVALTISCHE / MESAS OVALADAS

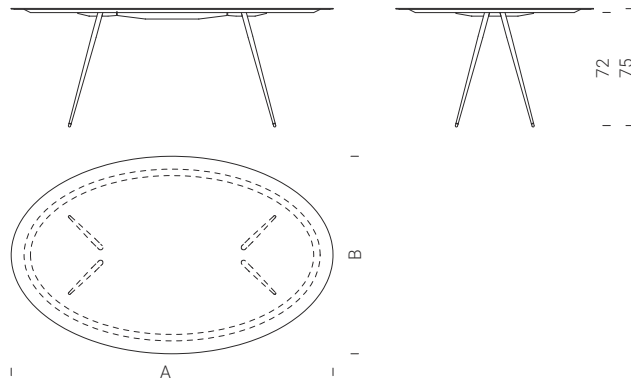

	A x B		S05 S06	S07 S08	L03 L06	L08 L10 L11	D01 D02 D03	C31 C32 C35 C36	Y36 Y34 Y37 Y39 Y40	N01 N02		
STAV0049	160 x 85	6	2201	2201	1931	2022	2344	3125	2323	2172	1453	+234
STAV0050	180 x 95	8	2324	2324	2039	2135	2474	3300	2452	2293	1492	+234
STAV0051	200 x 105	8	2586	2586	2269	2376	2754	3672	2729	2552	1710	+234
STAV0052	220 x 115	8	3119	3119	2736	2865	3321	4428	3291	3078	1926	+234
STAV0053	248 x 128	10	3486	-	3058	3202	-	-	3678	3439	2270	+234

TAVOLI TONDI E QUADRATI / ROUND AND SQUARE TABLES / TABLES RONDES ET CARR ES RUNDTISCHE UND QUADRATISCHE TISCHE / MESAS REDONDAS Y CUADRADAS

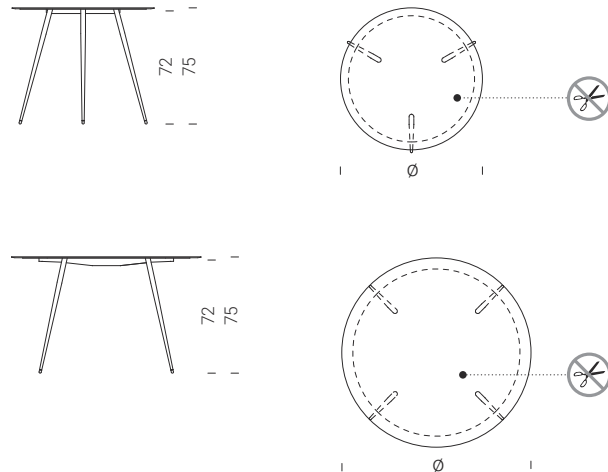

	�		S05 S06	S07 S08	L03 L06	L08 L10 L11	D01 D02 D03	C31 C32 C35 C36	Y36 Y34 Y37 Y39 Y40	N01 N02		
STAV0025	90	3	1328	1328	1165	1220	1414	1886	1402	1311	855	+195
STAV0026	110	5	1689	1689	1482	1551	1798	2398	1782	1667	1064	+195

	�		S05 S06	S07 S08	L03 L06	L08 L10 L11	D01 D02 D03	C31 C32 C35 C36	Y36 Y34 Y37 Y39 Y40	N01 N02		
STAV0027	128	6	2205	-	1934	2025	-	-	2327	2176	1424	+254
STAV0028	140	7	2247	-	1971	2064	-	-	2371	2217	1532	+293
STAV0016	160	8	2673	-	2344	2455	-	-	2820	2637	1850	+332



maggiorazione per esterno riparato solo per surcharge for sheltered outdoor only for majoration pour ext rieur prot g  juste pour Zuschlag f r drau en gesch tzt nur f r aumento para exterior reparado solo para

- S05 D01 L03 L08 C35**
- S06 D02 L06 L10 C36**
- S07 D03 L11**
- S08**



solo telaio (info pg.98)
frame only (info on pg.98)
seulement b ti (info pg.98)
Ausschlie lich Rahmen (Info pg.98)
solo marco (informaci n pg.98)



accessori disponibili a pg.119
accessories available on pg.119
accessoires disponibles pg.119
erh ltliches Zubeh r auf pg.119
accesorios disponibles en pg.119



disponibili riduzioni a misura
tailor-made reduction available
disponibles r ductions sur mesure
Verkleinerung nach Kundenwunsch
disponibles reducciones a medida

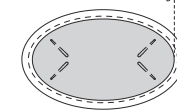

SRID0001
+240  

acciaio verniciato/painted steel/acier peint
lackierter Stahl/acero pintado

- C12 bianco/white
- C21 seta/silk
- C23 corda/ecru
- C30 ghisa/cast-iron
- C14 antracite/anthracite
- C08 nero/black
- C18 verde/green
- C26 corten/corten
- C29 bronzo/bronze
- C37 rame/copper
- C38 titanio/titanium



ceramica/ceramic/c eramique
Keramik/cer mico

- S05 antracite/anthracite
- S06 nero/black
- S07 porfido/porfido
- S08 cardoso/cardoso



HPL POLARIS®

- L03 bianco/white
- L10 grigio chiaro/light grey
- L11 grigio scuro/dark grey

HPL FENIX®

- L08 grigio Londra/London grey
- L06 nero/black



HPL+ cemento/concrete/ciment
zement/cemento

- D01 bianco calce/lime white
- D02 grigio Portland/Portland grey
- D03 nero/black

HPL+ metallo/metal/m tal/Metall/metal

- C31 ottone/brass
- C32 ottone scuro/dark brass
- C35 inox/inox
- C36 inox scuro/dark inox



HPL+ legno/wood/bois/Holz/madera

- Y36 rovere/oak
- Y34 noce/walnut
- Y37 rovere affumicato/smoked oak
- Y39 frassino nero/black ash
- Y40 frassino argilla/clay ash

HPL+ ecotouch

- N01 sabbia/sand
- N02 basalto/basalt

TAVOLI QUADRATI A BOTTE A GAMBE CENTRALI / SQUARE BARREL TABLES WITH CENTRAL LEG / TABLES   TONNEAU CARR ES AVEC PIEDS CENTRAUX
VIERECKIGE TONNENF RMIGE TISCHE MIT MITTELF  EN / MESAS CUADRADAS CON PATAS CENTRALES

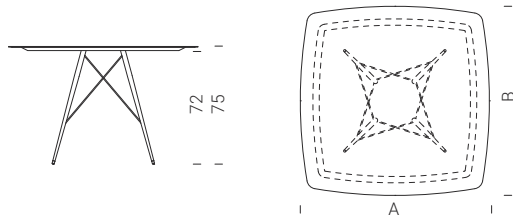

	A x B		S05 S06	S07 S08	L03 L06	L08 L10 L11	D01 D02 D03	C31 C32 C35 C36	Y36 Y34 Y37 Y39 Y40	N01 N02		
STAV0061	120 x 120	6	2206	2206	1935	2026	2348	3131	2327	2176	1424	+254
STAV0062	140 x 140	8	2672	-	2344	2455	-	-	2820	2637	1532	+293

TAVOLI ROTONDI A GAMBE CENTRALI / ROUND TABLES WITH CENTRAL LEG / TABLES RONDES AVEC PIEDS CENTRAUX
RUNDE TISCHE MIT MITTELF  EN / MESAS REDONDAS CON PATAS CENTRALES

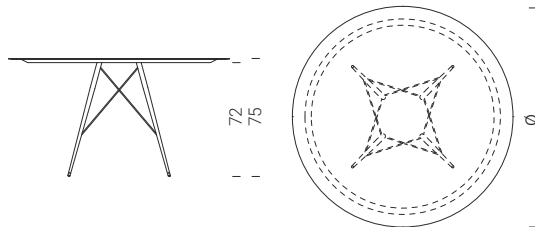

	�		S05 S06	S07 S08	L03 L06	L08 L10 L11	D01 D02 D03	C31 C32 C35 C36	Y36 Y34 Y37 Y39 Y40	N01 N02		
STAV0064	128	6	2245	-	1974	2065	-	-	2367	2216	1424	+254
STAV0065	140	7	2327	-	2011	2104	-	-	2411	2257	1532	+293
STAV0066	160	8	2713	-	2384	2495	-	-	2860	2677	1640	+352

TAVOLI BASSI / COFFEE TABLES / TABLES BASSES / COUCHTISCHE / MESAS BAJAS

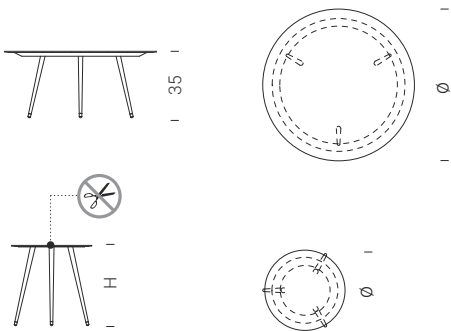

	� x H	S05 S06	S07 S08	L03 L06	L08 L10 L11	D01 D02 D03	C31 C32 C35 C36	Y36 Y34 Y37 Y39 Y40	N01 N02		
STAV0054	70 x 35	885	885	776	813	942	1256	934	873	531	+78
STAV0055	80 x 35	992	992	870	911	1056	1408	1046	978	626	+78
STAV0056	90 x 35	1107	1107	971	1017	1179	1572	1168	1093	705	+78
STAV0011	45 x 45	430	430	377	395	445	567	452	412	263	+78
STAV0012	55 x 45	522	522	458	479	540	688	548	500	306	+78
STAV0013	45 x 55	430	430	377	395	445	567	452	412	263	+78
STAV0014	55 x 55	522	522	458	479	540	688	548	500	306	+78

maggiorazione per esterno riparato solo per surcharge for sheltered outdoor only for majoration pour ext rieur prot g  juste pour Zuschlag f r drau en gesch tzt nur f r aumento para exterior reparado solo para

- S05 D01 L03 L08 C35
- S06 D02 L06 L10 C36
- S07 D03 L11
- S08

solo telaio (info pg.98)
frame only (info on pg.98)
seulement b ti (info pg.98)
Ausschlie lich Rahmen (Info pg.98)
solo marco (informaci n pg.98)

accessori disponibili a pg.119
accessories available on pg.119
accessoires disponibles pg.119
erh ltliches Zubeh r auf pg.119
accesorios disponibles en pg.119

disponibili riduzioni a misura
tailor-made reduction available
disponibles r ductions sur mesure
Verkleinerung nach Kundenwunsch
disponibles reducciones a medida

SRID001 +240  

SRID001 +240  

SRID001 +240  

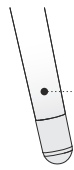

acciaio verniciato/painted steel/acier peint
lackierter Stahl/acero pintado

- C12** bianco/white
- C21** seta/silk
- C23** corda/ecru
- C30** ghisa/cast-iron
- C14** antracite/anthracite
- C08** nero/black
- C18** verde/green
- C26** corten/corten
- C29** bronzo/bronze
- C37** rame/copper
- C38** titanio/titanium



ceramica/ceramic/c eramique
Keramik/cer amico

- S05** antracite/anthracite
- S06** nero/black
- S07** porfido/porfido
- S08** cardoso/cardoso



HPL POLARIS®

- L03** bianco/white
- L10** grigio chiaro/light grey
- L11** grigio scuro/dark grey

HPL FENIX®

- L08** grigio Londra/London grey
- L06** nero/black



- HPL+ cemento/concrete/ciment
zement/cemento
- D01** bianco calce/lime white
 - D02** grigio Portland/Portland grey
 - D03** nero/black

HPL+ metallo/metal/m tal/Metall/metal

- C31** ottone/brass
- C32** ottone scuro/dark brass
- C35** inox/inox
- C36** inox scuro/dark inox



- HPL+ legno/wood/bois/Holz/madera
- Y36** rovere/oak
 - Y34** noce/walnut
 - Y37** rovere affumicato/smoked oak
 - Y39** frassino nero/black ash
 - Y40** frassino argilla/clay ash

HPL+ ecotouch

- N01** sabbia/sand
- N02** basalto/basalt

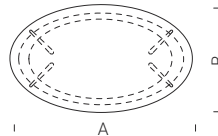
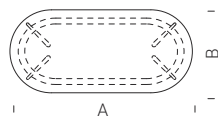

	A x B	S05 S06	S07 S08	L03 L06	L08 L10 L11	D01 D02 D03	C31 C32 C35 C36	Y36 Y34 Y37 Y39 Y40	N01 N02		
STAV0057	90 x 50	888	888	779	816	919	1171	932	851	590	+83
STAV0058	110 x 50	936	936	821	859	968	1234	982	897	599	+83
	A x B										
STAV0059	90 x 55	927	927	813	851	959	1222	973	889	599	+83
STAV0060	110 x 65	1225	1225	1074	1125	1267	1615	1286	1174	610	+83

PASSACAVO / CABLE GLAND / PASSE-C ABLE / KABELDURCHLASS / PASACABLES

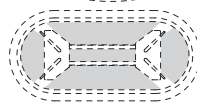
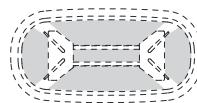
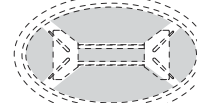
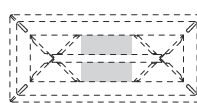
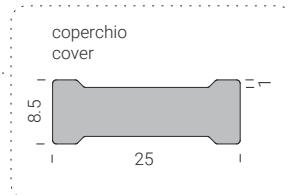
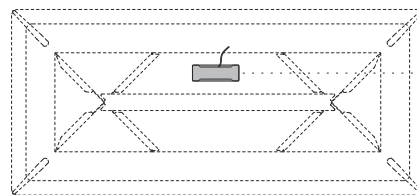
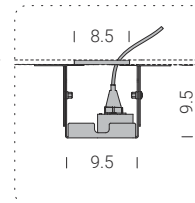
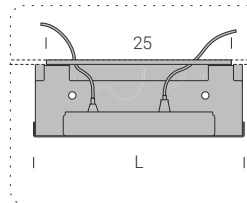
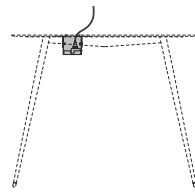
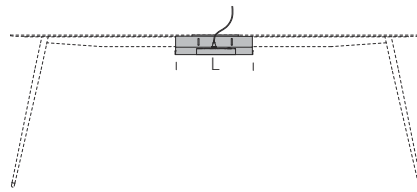

cesto in acciaio e copertura magnetica nelle finiture del tavolo.
steel basket and magnetic cover in the table finishings.
panier en acier et couvercle magn tique dans les m mes finitions que la table.
Stahlkorb und Magnetabdeckung in der Tischausf hrung.
cesto de acero y cubierta magn tica en los acabados de la mesa.

Il passacavi pu  essere posizionato esclusivamente nelle aree evidenziate.
the cable tidy can be placed only in the highlighted areas
le passe-c bles peut  tre plac  que dans le domaines mis en  vidence
das Kabeldurchf hrung kann nur in den hervorgehobenen Bereichen angeordnet werden
el pasacables se puede colocar s lo en las  reas resaltadas

	L	
SACC0003	28	185
SACC0004	40	205

vedi catalogo a pg.156
refer to catalogue pg.156
Voir catalogue pg. 156
siehe Katalog auf pg.156
v ase pg.156 del cat logo

VASSOI / TRAYS / PLATEAUX / TABLETS / BANDEJAS

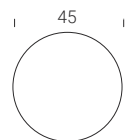

		S05 S06 S07 S08	L03 L06	L08 L10 L11	D01 D02 D03	C31 C32 C35 C36
SACC0007	45 x 1.5	190	165	180	205	245

vedi catalogo a pg.172 / refer to catalogue pg.172/Voir catalogue pg. 172
siehe Katalog auf pg.172/v ase pg.172 del cat logo



maggiorazione per esterno riparato solo per surcharge for sheltered outdoor only for majoration pour ext rieur prot g  juste pour Zuschlag f r drau en gesch tzt nur f r aumento para exterior reparado solo para

- S05 D01 L03 L08 C35**
- S06 D02 L06 L10 C36**
- S07 D03 L11**
- S08**



solo telaio (info pg.98)
frame only (info on pg.98)
seulement b ti (info pg.98)
Ausschlie lich Rahmen (Info pg.98)
solo marco (informaci n pg.98)



disponibili riduzioni a misura
tailor-made reduction available
disponibles r ductions sur mesure
Verkleinerung nach Kundenwunsch
disponibles reducciones a medida

SRID0001
+240  

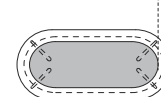

SRID0001
+240  

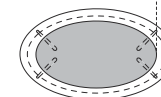

SINTESI



SEMPLICITÀ COSTRUTTIVA ED ESSENZA DEI MATERIALI DANNO VITA AL TAVOLO ALLUNGABILE "SINTESI". IL TELAIO È IN ACCIAIO PER CONSENTIRE SEZIONI RIBASSATE E MANTENERE PERFORMANCE DI ALLUNGO SINO A 300 CM. IL TOP È IN HPL E I COMPONENTI INTERNI SONO IN ALLUMINIO, OTTONE E ACCIAIO INOX, CIÒ RENDE COMPATIBILE IL TAVOLO ANCHE IN OUTDOOR.

Simple construction and the essence of materials bringing a "Sintesi" extendable table to life. The steel frame allows for lowered sections and maintains performance up to a length of 300 cm. The top is in HPL and the inner parts are in aluminium, brass and stainless steel, making the table compact for outdoor use.

La simplicité de construction et l'essence des matériaux donnent le jour à la table à rallonges "sintesi". La structure est en acier pour permettre des sections surbaissées et maintenir une performance d'allongement jusqu'à 300 cm. Le plateau est en HPL et les composants internes sont en aluminium, laiton et acier inox, ce qui rend la table compatible pour utilisation également en extérieur.

Die einfache Konstruktion und das Wesentliche der Materialien sind kennzeichnend für den ausziehbaren Tisch „sintesi“. Der Rahmen ist aus Stahl, um abgeflachte Querschnitte und Längen von max. 300 cm zu ermöglichen. Das Abschlussbord ist aus HPL und die Innenteile sind aus Aluminium, Messing und Edelstahl, dadurch ist der Tisch auch für Outdoor geeignet.

Su construcción sencilla y la esencia de sus materiales dan vida a la mesa extensible "Sintesi". El bastidor es de acero para permitir secciones rebajadas y mantener su capacidad de extensión hasta 300 cm. El sobre es de HPL y los componentes interiores son de aluminio, latón y acero inoxidable, lo que hace que la mesa también se pueda usar en el exterior.



Disponibili riduzioni a misura
Custom reductions available
Réductions sur mesure disponibles
Verkürzungen auf Maß erhältlich
Disponibles reducciones a medida



Passacavo disponibile per tutti i top
Cable gland available for all tops
Passe-câble disponible pour tous les plateaux
Kabeldurchlass für alle Abschlussborde verfügbar
Pasacables disponible para todos los sobres



Uso in esterno riparato
Use in a sheltered outdoor space
Utilisation en extérieur, en espace abrité
Verwendung in geschütztem Außenbereich
Uso exterior protegido

- acciaio verniciato/painted steel/acier peint
lackierter Stahl/acero pintado
- C12 bianco/white
 - C21 seta/silk
 - C23 corda/ecru
 - C30 ghisa/cast-iron
 - C14 antracite/anthracite
 - C08 nero/black
 - C18 verde/green
 - C26 corten/corten
 - C29 bronzo/bronze
 - C37 rame/copper
 - C38 titanio/titanium

- ceramica/ceramic/c eramique
Keramik/cer mico
- S05 antracite/anthracite
 - S06 nero/black
 - S07 porfido/porfido
 - S08 cardoso/cardoso

- HPL POLARIS®
- L03 bianco/white
 - L10 grigio chiaro/light grey
 - L11 grigio scuro/dark grey
- HPL FENIX®
- L08 grigio Londra/London grey
 - L06 nero/black

- HPL+ legno/wood/bois/Holz/madera
- Y36 rovere/oak
 - Y34 noce/walnut
 - Y37 rovere affumicato/smoked oak
 - Y39 frassino nero/black ash
 - Y40 frassino argilla/clay ash

TAVOLI ALLUNGABILI / EXTENDABLE TABLES / TABLES EXTENSIBLES AUSZIEHBARE TISCHE / MESAS EXTENSIBLES

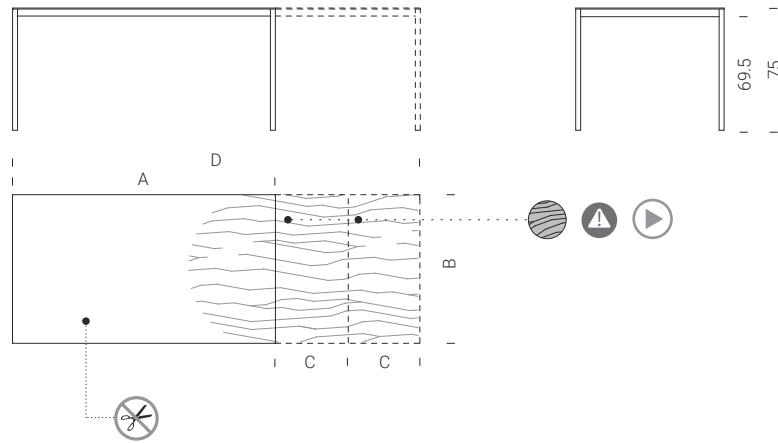

	A / D x B	C	Icon	S05	S06	L08	Y36
				S07	L03		
				S08	L06	L11	Y37
							Y39
							Y40
OTAV0003	130 / 180 x 78	50	6 (8)	2744	2560	2680	2881
OTAV0001	130 / 180 x 90	50	6 (8)	2966	2775	2914	3131
OTAV0005	160 / 240 x 78	40+40	6 (10)	3222	3007	3167	3402
OTAV0006	160 / 240 x 90	40+40	6 (10)	3552	3265	3449	3704
OTAV0002	200 / 300 x 90	50+50	8 (12)	3814	3631	3800	4077
OTAV0058	200 / 300 x 98	50+50	8 (12)	4119	3922	4104	4404

le allunghe possono essere posizionate all'interno del tavolo.
the extensions can be positioned inside the table.
les rallonges peuvent  tre plac es   l'int rieur de la table.
die Verl ngerungen k nnen innerhalb des Tisches gelegt werden.
las extensiones pueden colocarse dentro de la mesa.

PANCHE ALLUNGABILI / EXTENDABLE BENCHES / BANCS EXTENSIBLES AUSZIEHBARE B NKE / BANQUILLOS EXTENSIBLES

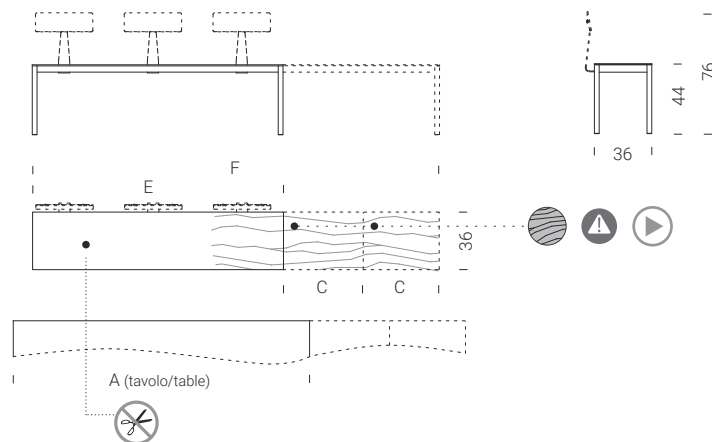

	E / F x 36	C	A	Icon	S05	S06	L08	Y36
					S07	L03		
					S08	L06	L11	Y37
								Y39
								Y40
OPAN0001	90 / 140 x 36	50	130	2 (3)	1684	1520	1564	1718
OPAN0002	120 / 200 x 36	40+40	160	2 (4)	1886	1702	1752	1924
OPAN0003	160 / 260 x 36	50+50	200	3 (5)	2433	2236	2284	2508

le allunghe possono essere posizionate all'interno del tavolo.
the extensions can be positioned inside the table.
les rallonges peuvent  tre plac es   l'int rieur de la table.
die Verl ngerungen k nnen innerhalb des Tisches gelegt werden.
las extensiones pueden colocarse dentro de la mesa.

schienali e cuscini non inclusi nel prezzo, info pagina 131
backrests and cushions not included in the price, info on page 131
dossiers et coussins non inclus dans le prix, info page 131
R ckenteile und Kissen nicht im Preis inbegriffen, Info Seite 131
respaldos y cojines no incluidos en el precio, p gina de informaci n 131

impiallacciatura continua su top e allunghe
continues veneer on top and extensions
les veines du placage bois suivent sur les rallonges
sauberer Furnierverlauf  ber Tisch- und Verl ngerungsplatte
chapa de madera contin a en el plano y extensiones

top e allunghe nella stessa finitura
top and extensions with the same finish
plateau et rallonges dans la m me finition
Abdeck- und Ausziehplatten in derselben Vollendung
Encimera y extensiones en el mismo acabado

Apertura allunghe
Opening of extensions
Ouverture de rallonges
 ffnung verl ngerungsst cke
Apertura de la extensi n

acciaio verniciato/painted steel/acier peint
lackierter Stahl/acero pintado

- C12 bianco/white
- C21 seta/silk
- C23 corda/ecru
- C30 ghisa/cast-iron
- C14 antracite/anthracite
- C08 nero/black
- C18 verde/green
- C26 corten/corten
- C29 bronzo/bronze
- C37 rame/copper
- C38 titanio/titanium

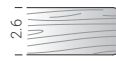

- legno massiccio/solid wood
bois massif/Massivholz
madera maciza
- T01 rovere/oak
 - T02 noce/walnut
 - T03 iroko
 - T04 iroko outdoor
 - T05 rovere nero/black oak

- ceramica/ceramic/c eramique
Keramik/cer mico
- S05 antracite/anthracite
 - S06 nero/black
 - S07 porfido/porfido
 - S08 cardoso/cardoso

- HPL POLARIS®
- L03 bianco/white
 - L10 grigio chiaro/light grey
 - L11 grigio scuro/dark grey
- HPL FENIX®
- L08 grigio Londra/London grey
 - L06 nero/black

- HPL+ cemento/concrete/ciment
zement/cemento
- D01 bianco calce/lime white
 - D02 grigio Portland/Portland grey
 - D03 nero/black
- HPL+ metallo/metal/m tal/Metall/metal
- C31 ottone/brass
 - C32 ottone scuro/dark brass
 - C35 inox/inox
 - C36 inox scuro/dark inox

- HPL+ legno/wood/bois/Holz/madera
- Y36 rovere/oak
 - Y34 noce/walnut
 - Y37 rovere affumicato/smoked oak
 - Y39 frassino nero/black ash
 - Y40 frassino argilla/clay ash
- HPL+ ecotouch
- N01 sabbia/sand
 - N02 basalto/basalt

TAVOLI RETTANGOLARI E QUADRATI / RECTANGULAR AND SQUARE TABLES / TABLES RECTANGULAIRES ET CARR ES
RECHTECKIGE UND QUADRATISCHE TISCHE / MESAS RECTANGULARES Y CUADRADAS

SINTESI

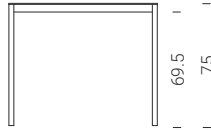

	A x B		T01 T03 T04	T02 T05	S05 S06	S07 S08	L03 L06	L08 L10 L11	D01 D02 D03	C31 C32 C35 C36	Y36 Y34 Y37 Y39 Y40	N01 N02		
OTAV0007	120 x 78	4	2023	2156	1619	1619	1512	1572	1787	2211	1726	1659	1203	+228
OTAV0028	140 x 78	6	2180	2343	1770	1770	1623	1718	1955	2450	1886	1805	1291	+228
OTAV0030	160 x 78	6	2224	2410	1838	1838	1705	1785	2031	2601	1957	1861	1356	+228
OTAV0009	180 x 78	8	2585	2794	1912	1912	1766	1856	2114	2757	2035	1922	1405	+228
OTAV0019	200 x 78	8	2743	2974	2135	2135	1974	2073	2361	3065	2272	2149	1571	+228
OTAV0008	120 x 90	6	2142	2282	1752	1752	1631	1701	1935	2424	1866	1787	1298	+228
OTAV0029	140 x 90	6	2385	2573	1914	1914	1748	1858	2115	2687	2039	1942	1391	+228
OTAV0031	160 x 90	6	2449	2663	1993	1993	1816	1935	2204	2860	2121	2006	1445	+228
OTAV0010	180 x 90	8	2831	3073	2067	2067	1865	2007	2287	3022	2199	2065	1484	+228
OTAV0020	200 x 90	8	3004	3271	2311	2311	2129	2243	2556	3369	2458	2312	1694	+342
OTAV0059	220 x 90	8	3154	3435	2426	2426	2266	2356	2684	3537	2581	2427	1779	+342
OTAV0012	240 x 90	10	3312	3634	2443	2443	2324	2372	2705	3984	2596	2509	1870	+342
OTAV0014	300 x 90	12	3822	4222	2860	2860	2605	2777	3169	4767	3037	2801	2073	+456
OTAV0021	200 x 98	8	3150	3441	2470	2470	2274	2398	2733	3616	2627	2467	1809	+342
OTAV0060	220 x 98	8	3308	3613	2594	2594	2387	2518	2869	3797	2759	2590	1900	+342
OTAV0017	240 x 98	10	3593	3943	2665	2665	2425	2587	2950	4347	2831	2628	1930	+342
OTAV0018	300 x 98	12	4204	4639	3086	3086	2809	2996	3419	5156	3276	3019	2235	+456
OTAV0022	200 x 120	10	3487	3852	2823	-	2533	2741	3090	4882	2990	2622	2015	+342
OTAV0061	220 x 120	10	3662	4044	2964	-	2659	2878	3245	5126	3144	2753	2116	+342
OTAV0023	240 x 120	10	3947	4359	3024	-	2752	2936	3309	5360	3211	2956	2190	+342
OTAV0024	300 x 120	12	4416	4878	3551	-	3218	3448	3884	6059	3768	3447	2561	+456

	A x B		T01 T03 T04	T02 T05	S05 S06	S07 S08	L03 L06	L08 L10 L11	D01 D02 D03	C31 C32 C35 C36	Y36 Y34 Y37 Y39 Y40	N01 N02		
OTAV0055	78 x 78	2	1577	1681	1263	1263	1169	1226	1387	1737	1344	1283	937	+228
OTAV0056	90 x 90	4	1712	1825	1371	1371	1270	1331	1508	1886	1459	1392	937	+228
OTAV0057	98 x 98	4	1939	2067	1552	1552	1438	1507	1706	2134	1653	1578	1039	+228
OTAV0050	120 x 120	6	2525	2789	2147	-	1958	2085	2352	3220	2287	2176	1559	+228
OTAV0054	140 x 140	8	2925	3389	2879	-	2624	2796	-	-	3066	2762	2088	+456
OTAV0051	158 x 158	8	3367	3719	3359	-	3101	3261	-	-	3574	3372	2467	+456

maggiorazione per esterno riparato solo per surcharge for sheltered outdoor only for majoration pour ext rieur prot g  juste pour Zuschlag f r drau en gesch tzt nur f r aumento para exterior reparado solo para

T04 S05 D01 L03 L08 C35
S06 D02 L06 L10 C36
S07 D03 L11
S08

solo telaio (info pg.99)
frame only (info on pg.99)
seulement b ti (info pg.99)
Ausschlie lich Rahmen (Info pg.99)
solo marco (informaci n pg.99)

accessori non inclusi, disponibili a pg.128
accessories not included, available on pg.128
Accessoires non inclus, disponibles pg.128
Zubeh r nicht inbegriffen, erh ltlich auf pg.128
accesorios no incluidos, disponibles en pg.128

disponibili riduzioni a misura
tailor-made reduction available
disponibles r ductions sur mesure
Verkleinerung nach Kundenwunsch
disponibles reducciones a medida

ORID0001
+240  



- acciaio verniciato/painted steel/acier peint
lackierter Stahl/acero pintado
- C12** bianco/white
 - C21** seta/silk
 - C23** corda/ecru
 - C30** ghisa/cast-iron
 - C14** antracite/anthracite
 - C08** nero/black
 - C18** verde/green
 - C26** corten/corten
 - C29** bronzo/bronze
 - C37** rame/copper
 - C38** titanio/titanium

- legno massiccio/solid wood
bois massif/Massivholz
madera maciza
- T01** rovere/oak
 - T02** noce/walnut
 - T03** iroko
 - T04** iroko outdoor
 - T05** rovere nero/black oak

- ceramica/ceramic/c ramique
Keramik/cer mico
- S05** antracite/anthracite
 - S06** nero/black
 - S07** porfido/porfido
 - S08** cardoso/cardoso

- HPL POLARIS®
- L03** bianco/white
 - L10** grigio chiaro/light grey
 - L11** grigio scuro/dark grey
- HPL FENIX®
- L08** grigio Londra/London grey
 - L06** nero/black

- HPL+ cemento/concrete/ciment
zement/cemento
- D01** bianco calce/lime white
 - D02** grigio Portland/Portland grey
 - D03** nero/black
- HPL+ metallo/metal/m tal/Metall/metal
- C31** ottone/brass
 - C32** ottone scuro/dark brass
 - C35** inox/inox
 - C36** inox scuro/dark inox

- HPL+ legno/wood/bois/Holz/madera
- Y36** rovere/oak
 - Y34** noce/walnut
 - Y37** rovere affumicato/smoked oak
 - Y39** frassino nero/black ash
 - Y40** frassino argilla/clay ash
- HPL+ ecotouch
- N01** sabbia/sand
 - N02** basalto/basalt

**PANCHE FISSE / FIXED BENCHES / BANCS FIXES
FESTE B NKE / BANQUILLOS FIJOS**

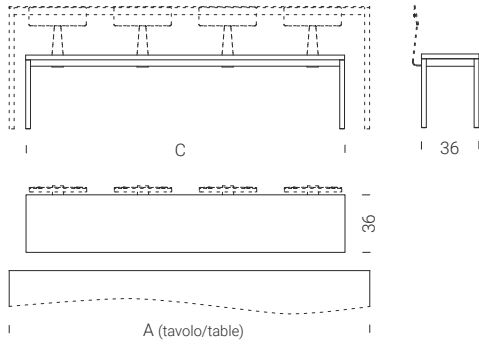

	C x D	A		T01 T03 T04	T02 T05	S05 S06 S07 S08	L03 L06	L08 L10 L11	D01 D02 D03	C31 C32 C35 C36	Y36 Y34 Y37 Y39 Y40	N01 N02		
OPAN0004	90 x 36	120	2	1333	1499	983	954	1045	1172	1543	1124	1064	953	+228
OPAN0005	110 x 36	140	2	1446	1568	1027	997	1093	1225	1613	1176	1113	953	+228
OPAN0006	130 x 36	160	2	1509	1636	1072	1041	1140	1279	1683	1227	1161	953	+228
OPAN0007	150 x 36	180	3	1584	1718	1126	1093	1197	1343	1768	1288	1219	953	+228
OPAN0008	160 x 36	200	3	1627	1764	1156	1122	1229	1379	1815	1323	1252	953	+228
OPAN0012	180 x 36	220	3	1792	1952	1245	1205	1330	1504	2011	1438	1356	953	+228
OPAN0009	200 x 36	240	4	1873	2031	1331	1292	1416	1588	2090	1523	1441	953	+228
OPAN0010	260 x 36	300	5	1992	2152	1445	1405	1530	1704	2211	1638	1556	953	+228

maggiorazione per esterno riparato solo per surcharge for sheltered outdoor only for majoration pour ext rieur prot g  juste pour Zuschlag f r drau en gesch tzt nur f r aumento para exterior reparado solo para

T04 S05 D01 L03 L08 C35
S06 D02 L06 L10 C36
S07 D03 L11
S08

solo telaio (info pg.99)
frame only (info on pg.99)
seulement b ti (info pg.99)
Ausschlie lich Rahmen (Info pg.99)
solo marco (informaci n pg.99)

accessori non inclusi, disponibili a pg.131
accessories not included, available on pg.131
Accessoires non inclus, disponibles pg.131
Zubeh r nicht inbegriffen, erh ltlich auf pg.131
accesorios no incluidos, disponibles en pg.131

disponibili riduzioni a misura
tailor-made reduction available
disponibles r ductions sur mesure
Verkleinerung nach Kundenwunsch
disponibles reducciones a medida

ORID0002
+180  

acciaio verniciato/painted steel/acier peint
lackierter Stahl/acero pintado

- C12** bianco/white
- C21** seta/silk
- C23** corda/ecru
- C30** ghisa/cast-iron
- C14** antracite/anthracite
- C08** nero/black
- C18** verde/green
- C26** corten/corten
- C29** bronzo/bronze
- C37** rame/copper
- C38** titanio/titanium

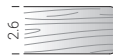

- legno massiccio/solid wood
bois massif/Massivholz
madera maciza
- T01** rovere/oak
 - T02** noce/walnut
 - T03** iroko
 - T04** iroko outdoor
 - T05** rovere nero/black oak

TAVOLI DOGATI / SLATTED TABLES / TABLES À LATTES
DAUBEN-TISCHE / MESAS LAMINADAS

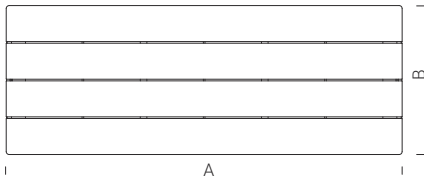
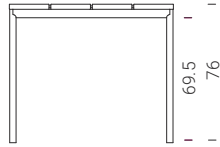

SINTESI

	A x B		T01 T03	T02 T05	 T04
OTAV0032	120 x 78	4	2364	2519	2592
OTAV0034	140 x 78	6	2531	2697	2759
OTAV0036	160 x 78	6	2762	2943	2990
OTAV0038	180 x 78	8	2828	3014	3056
OTAV0040	200 x 78	8	3225	3436	3453
OTAV0033	120 x 90	6	2502	2666	2730
OTAV0035	140 x 90	6	2680	2856	2908
OTAV0037	160 x 90	6	2813	2998	3041
OTAV0039	180 x 90	8	2852	3040	3080
OTAV0041	200 x 90	8	3266	3479	3608
OTAV0064	220 x 90	8	3592	3827	3934
OTAV0044	240 x 90	10	3848	4102	4119
OTAV0047	300 x 90	12	4295	4573	4751
OTAV0042	200 x 98	8	3332	3552	3674
OTAV0066	220 x 98	8	3666	3907	4008
OTAV0045	240 x 98	10	4052	4318	4394
OTAV0048	300 x 98	12	4427	4718	4883
OTAV0043	200 x 120	10	3962	4224	4304
OTAV0068	220 x 120	10	4359	4646	4701
OTAV0046	240 x 120	10	4485	4780	4827
OTAV0049	300 x 120	12	5019	5348	5475

	A x B				
OTAV0062	78 x 78	2	1843	1964	2071
OTAV0063	90 x 90	4	2000	2132	2228
OTAV0065	98 x 98	4	2265	2415	2493
OTAV0067	120 x 120	6	2870	3058	3098
OTAV0073	140 x 140	8	3656	4236	4282
OTAV0074	158 x 158	8	4208	4648	4664



esterno **T04**
outdoor **T04**
extérieur **T04**
draußen **T04**
exterior **T04**



disponibili riduzioni a misura
tailor-made reduction available
disponibles réductions sur mesure
Verkleinerung nach Kundenwunsch
disponibles reducciones a medida

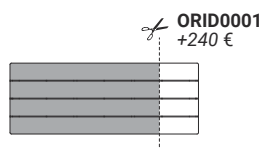

acciaio verniciato/painted steel/acier peint
lackierter Stahl/acero pintado

C12 bianco/white
C21 seta/silk
C23 corda/ecru
C30 ghisa/cast-iron
C14 antracite/anthracite
C08 nero/black
C18 verde/green
C26 corten/corten
C29 bronzo/bronze
C37 rame/copper
C38 titanio/titanium

legno massiccio/solid wood
bois massif/Massivholz
madera maciza

T01 rovere/oak
T02 noce/walnut
T03 iroko
T04 iroko outdoor
T05 rovere nero/black oak

ceramica/ceramic/c eramique
Keramik/cer amico

S05 antracite/anthracite
S06 nero/black
S07 porfido/porfido
S08 cardoso/cardoso

HPL POLARIS®

L03 bianco/white
L10 grigio chiaro/light grey
L11 grigio scuro/dark grey

HPL FENIX®

L08 grigio Londra/London grey
L06 nero/black

HPL+ cemento/concrete/ciment
zement/cemento

D01 bianco calce/lime white
D02 grigio Portland/Portland grey
D03 nero/black

HPL+ metallo/metal/m tal/Metall/metal

C31 ottone/brass
C32 ottone scuro/dark brass
C35 inox/inox
C36 inox scuro/dark inox

HPL+ legno/wood/bois/Holz/madera

Y36 rovere/oak
Y34 noce/walnut
Y37 rovere affumicato/smoked oak
Y39 frassino nero/black ash
Y40 frassino argilla/clay ash

HPL+ ecotouch

N01 sabbia/sand
N02 basalto/basalt

PANCHE DOGATE / SLATTED BENCHES / BANCS   LATTES
DAUBEN-B NKE / BANCOS LAMINADOS

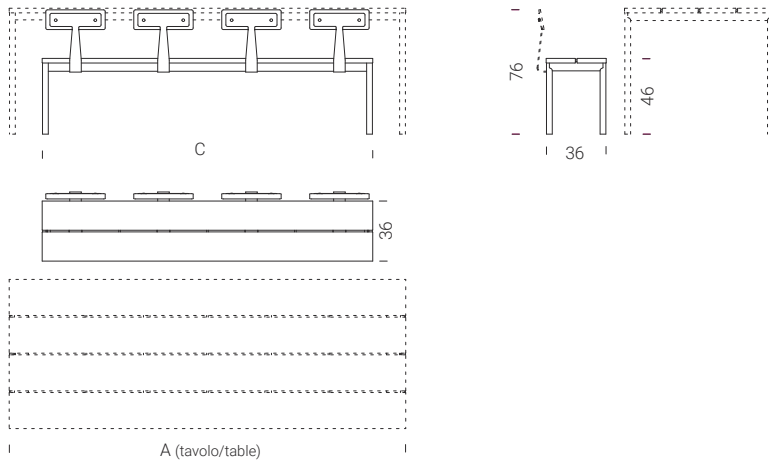

	C x D	A		T01 T03	T02 T05		T04
OPAN0013	90 x 36	120	2	1503	1603	1731	
OPAN0014	110 x 36	140	2	1571	1675	1799	
OPAN0015	130 x 36	160	2	1639	1748	1867	
OPAN0016	150 x 36	180	3	1722	1835	1950	
OPAN0017	160 x 36	200	3	1768	1885	1993	
OPAN0018	180 x 36	220	3	1945	2073	2173	
OPAN0019	200 x 36	240	4	2036	2170	2264	
OPAN0020	260 x 36	300	5	2157	2292	2385	

SCRITTOI / WRITING DESK / SECR TAIRES/ SCHREIBTISCHEN / ESCRITORIOS

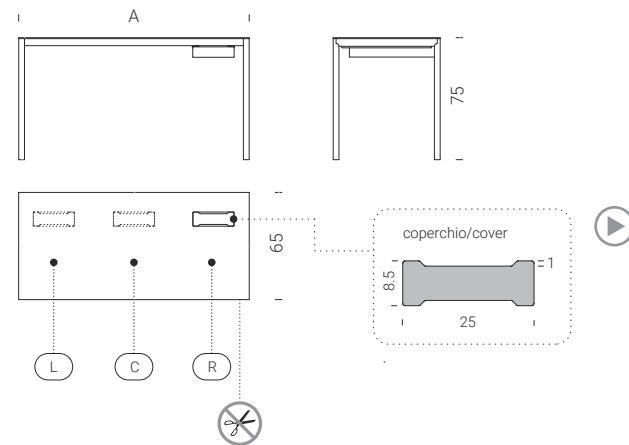

	A x B	T01 T03 T04	T02 T05	S05 S06 S07 S08	L03 L06	L08 L10 L11	D01 D02 D03	C31 C32 C35 C36	Y36 Y34 Y37 Y39 Y40	N01 N02
OTAV0069	100 x 65	2146	2271	1766	1665	1722	1924	2322	1866	1803
OTAV0070	120 x 65	2283	2416	1879	1772	1832	2047	2471	1986	1919
OTAV0071	140 x 65	2440	2603	2030	1883	1978	2215	2710	2146	2065
OTAV0072	160 x 65	2484	2670	2098	1965	2045	2291	2861	2217	2121

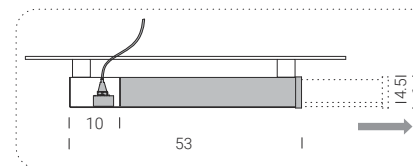

cassetto in acciaio e frontale nelle finiture del tavolo.
steel drawer and front in the table finishings.
 tiroir en acier et fa ade dans les m mes finitions que la table.
Stahlschublade und Vorderseite in den Tischausf hrungen.
caj n de acero y frontal en los acabados de la mesa.

esterno **T04**
outdoor **T04**
ext rieur **T04**
drau en **T04**
exterior **T04**

disponibili riduzioni a misura
tailor-made reduction available
disponibles r ductions sur mesure
Verkleinerung nach Kundenwunsch
disponibles reducciones a medida

ORID0002
+180  

ordinabile in posizione C (centrale).
available in the following positions: C (central).
peut  tre command  en position C (centrale).
aufstellbar in Position C (Mitte).
disponible en posici n C (central).

ordinabile in posizione L (sinistra), C (centrale), R (destra).
available in the following positions: L (left), C (central), R (right).
peut  tre command  en position L (gauche), C (centrale), R (droite).
aufstellbar in Position L (links), C (Mitte), R (rechts).
disponible en posici n L (izquierda), C (central), R (derecha).

Passacavi scrittoio
Writing desk cable sleeve
Passe-c bles pour bureau
Kabeldurchgang schreibtisch
Pasacables escritorio

acciaio verniciato/painted steel/acier peint
lackierter Stahl/acero pintado

- C12 bianco/white
- C21 seta/silk
- C23 corda/ecru
- C30 ghisa/cast-iron
- C14 antracite/anthracite
- C08 nero/black
- C18 verde/green
- C26 corten/corten
- C29 bronzo/bronze
- C37 rame/copper
- C38 titanio/titanium

0.6
ceramica/ceramic/c eramique
Keramik/cer mico

- S05 antracite/anthracite
- S06 nero/black
- S07 porfido/porfido
- S08 cardoso/cardoso

0.6

HPL POLARIS®

- L03 bianco/white
- L10 grigio chiaro/light grey
- L11 grigio scuro/dark grey

HPL FENIX®

- L08 grigio Londra/London grey
- L06 nero/black

0.7

HPL+ cemento/concrete/ciment
zement/cemento

- D01 bianco calce/lime white
- D02 grigio Portland/Portland grey
- D03 nero/black

HPL+ metallo/metal/m tal/Metall/metal

- C31 ottone/brass
- C32 ottone scuro/dark brass
- C35 inox/inox
- C36 inox scuro/dark inox

0.7

HPL+ legno/wood/bois/Holz/madera

- Y36 rovere/oak
- Y34 noce/walnut
- Y37 rovere affumicato/smoked oak
- Y39 frassino nero/black ash
- Y40 frassino argilla/clay ash

HPL+ ecotouch

- N01 sabbia/sand
- N02 basalto/basalt

TAVOLI COMPONIBILI / MODULAR TABLES / TABLES MODULABLES KOMPONIERBARE TISCHE / MESAS MODULARES

SINTESI

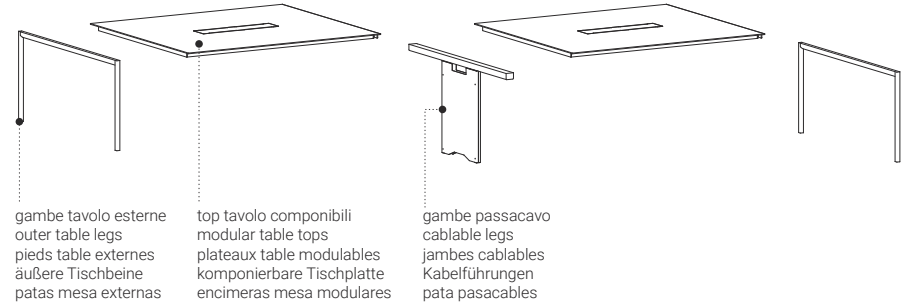
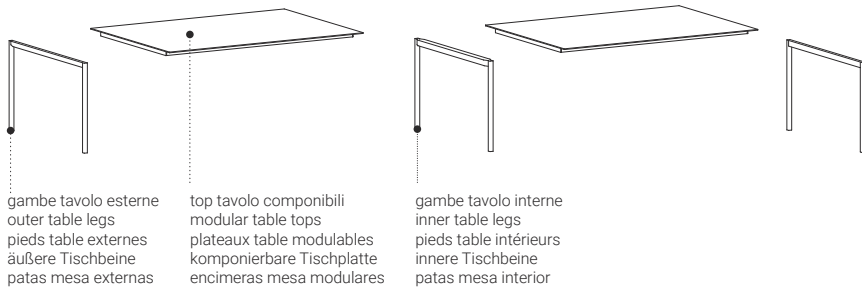

TOP TAVOLO COMPONIBILI / MODULAR TABLE TOPS / PLATEAUX TABLE MODULABLES KOMPONIERBARE TISCHPLATTE / ENCIMERAS MESA MODULARES

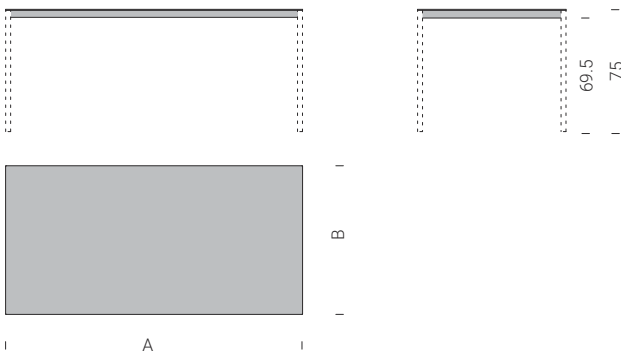

	A x B		S05 S06	S07 S08	L03 L06	L08 L10 L11	D01 D02 D03	C31 C32 C35 C36	Y36 Y34 Y37 Y39 Y40	N01 N02
OTOP0001	120 x 78	4	1061	1061	954	1014	1229	1653	1168	1101
OTOP0002	140 x 78	6	1212	1212	1065	1160	1397	1892	1328	1247
OTOP0003	160 x 78	6	1280	1280	1147	1227	1473	2043	1399	1303
OTOP0004	180 x 78	8	1354	1354	1208	1298	1556	2199	1477	1364
OTOP0005	200 x 78	8	1577	1577	1416	1515	1803	2507	1714	1591
OTOP0006	120 x 120	8	1455	-	1266	1393	1660	2528	1595	1484
OTOP0007	200 x 120	10	2131	-	1841	2049	2398	4190	2398	1930
OTOP0018	220 x 120	10	2272	-	1967	2186	2553	4434	2552	2061
OTOP0008	240 x 120	10	2332	-	2060	2244	2617	4668	2619	2264
OTOP0009	300 x 120	12	2859	-	2526	2756	3192	5367	3076	2755



accessori disponibili a pg.128
accessories available on pg.128
accessoires disponibles pg.128
erh ltliches Zubeh r auf pg.128
acessorios disponibles en pg.128



disponibili riduzioni a misura
tailor-made reduction available
disponibles r ductions sur mesure
Verkleinerung nach Kundenwunsch
disponibles reducciones a medida

ORID0001

+240  

ORID0001

+240  



- acciaio verniciato/painted steel/acier peint
lackierter Stahl/acero pintado
- C12 bianco/white
 - C21 seta/silk
 - C23 corda/ecru
 - C30 ghisa/cast-iron
 - C14 antracite/anthracite
 - C08 nero/black
 - C18 verde/green
 - C26 corten/corten
 - C29 bronzo/bronze
 - C37 rame/copper
 - C38 titanio/titanium

- ceramica/ceramic/c eramique
Keramik/cer mico
- S05 antracite/anthracite
 - S06 nero/black
 - S07 porfido/porfido
 - S08 cardoso/cardoso

- HPL POLARIS®
- L03 bianco/white
 - L10 grigio chiaro/light grey
 - L11 grigio scuro/dark grey
- HPL FENIX®
- L08 grigio Londra/London grey
 - L06 nero/black

- HPL+ legno/wood/bois/Holz/madera
- Y36 rovere/oak
 - Y34 noce/walnut
 - Y37 rovere affumicato/smoked oak
 - Y39 frassino nero/black ash
 - Y40 frassino argilla/clay ash
- HPL+ ecotouch
- N01 sabbia/sand
 - N02 basalto/basalt

TOP TAVOLO COMPONENTI / MODULAR TABLE TOPS / PLATEAUX TABLE MODULABLES
KOMPONIERBARE TISCHPLATTE / ENCIMERAS MESA MODULARES

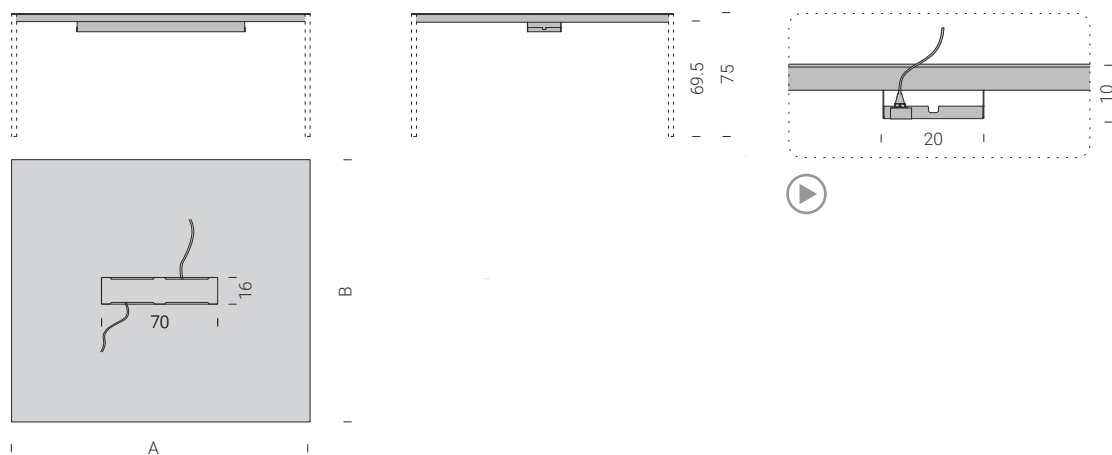

	A x B		S05 S06	S07 S08	L03 L06	L08 L10 L11	Y36 Y34 Y37 Y39 Y40	N01 N02
OTOP0014	120 x 140	8	2252	-	1924	2186	2400	2157
OTOP0015	140 x 140	8	2335	-	1994	2267	2499	2237
OTOP0016	160 x 140	8	2464	-	2104	2392	2624	2360
OTOP0017	180 x 140	10	2636	-	2252	2559	2808	2525
OTOP0010	120 x 158	8	2371	-	2025	2302	2526	2271
OTOP0013	140 x 158	8	2459	-	2100	2387	2620	2355
OTOP0011	160 x 158	8	2594	-	2215	2518	2763	2484
OTOP0012	180 x 158	10	2775	-	2370	2694	2957	2658

GAMBE TAVOLO ESTERNE / OUTER TABLE LEGS / PIEDS TABLE EXTERNES
 U ERE TISCHBEINE / PATAS MESA EXTERNAS

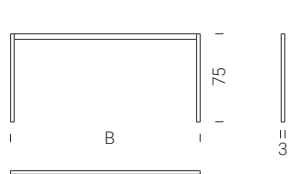

	B x 75	C
OGAM0001	78 x 75	279
OGAM0004	120 x 75	346
OGAM0014	140 x 75	423
OGAM0005	158 x 75	499

GAMBE TAVOLO INTERNE / INNER TABLE LEGS / PIEDS TABLE INT RIEURS
INNERE TISCHBEINE / PATAS MESA INTERIOR

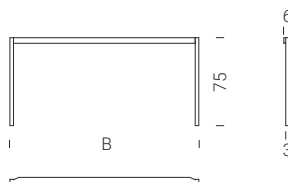

	B x 75	C
OGAM0011	78 x 75	529
OGAM0012	120 x 75	566
OGAM0015	140 x 75	595
OGAM0013	158 x 75	623

GAMBE PASSACAVO / CABLABLE LEGS / JAMBES CABLABLES
KABELF HRUNGEN / PATA PASACABLES

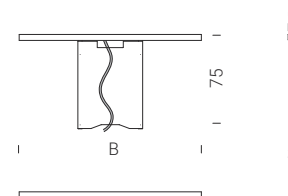

	B x 75	C
OGAM0009	120 x 75	581
OGAM0016	140 x 75	621
OGAM0010	158 x 75	663

accessori disponibili a pg.128
accessories available on pg.128
accessoires disponibles pg.128
erh ltliches Zubeh r auf pg.128
accesorios disponibles en pg.128

Passacavi tavolo studio
Office desk cable sleeve
Passe-c bles pour table de bureau
Kabeldurchgang b rotisch
Pasacables mesa de trabajo

C acciaio verniciato/painted steel/acier peint
lackierter Stahl/acero pintado

- C12** bianco/white
- C21** seta/silk
- C23** corda/ecru
- C30** ghisa/cast-iron
- C14** antracite/anthracite
- C08** nero/black
- C18** verde/green
- C26** corten/corten
- C29** bronzo/bronze
- C37** rame/copper
- C38** titanio/titanium

Q vetro laccato/lacquered glass/verre laqué
Glas Lackiert/cristal lacado

- Q05** bianco/white
- Q16** seta/silk
- Q17** corda/ecru
- Q20** ghisa/cast-iron
- Q14** antracite/anthracite
- Q04** nero/black
- Q21** bronzo/bronze

PASSACAVO / CABLE GLAND / PASSE-CÂBLE / KABELDURCHGLASS / PASACABLES

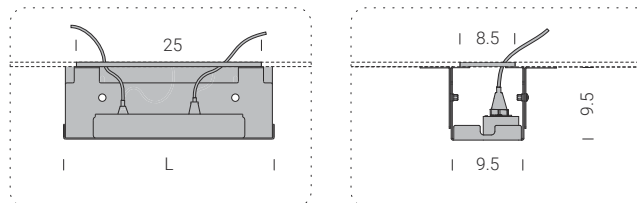
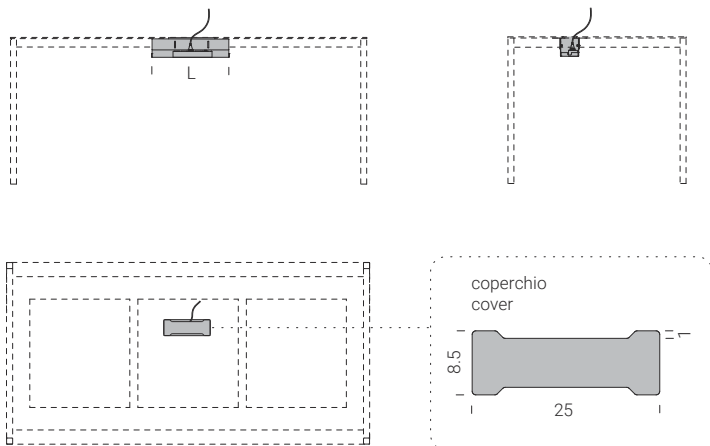

cesto in acciaio e copertura magnetica nelle finiture del tavolo.
steel basket and magnetic cover in the table finishings.
panier en acier et couvercle magnétique dans les mêmes finitions que la table.
Stahlkorb und Magnetabdeckung in der Tischausführung.
cesto de acero y cubierta magnética en los acabados de la mesa.

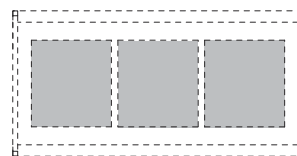

Il passacavi può essere posizionato esclusivamente nelle aree evidenziate.
the cable tidy can be placed only in the highlighted areas
le passe-câbles peut être placé que dans le domaines mis en évidence
das Kabeldurchführung kann nur in den hervorgehobenen Bereichen angeordnet werden
el pasacables se puede colocar sólo en las áreas resaltadas

	L	C
SACC0003	28	185
SACC0004	40	205

vedi catalogo a pg.156
refer to catalogue pg.156
Voir catalogue pg. 156
siehe Katalog auf pg.156
véase pg.156 del catálogo

PRIVACY PANEL / PRIVACY PANEL / PANNEAU DE SÉPARATION / PRIVACY PANEL / PANEL PRIVACIDAD

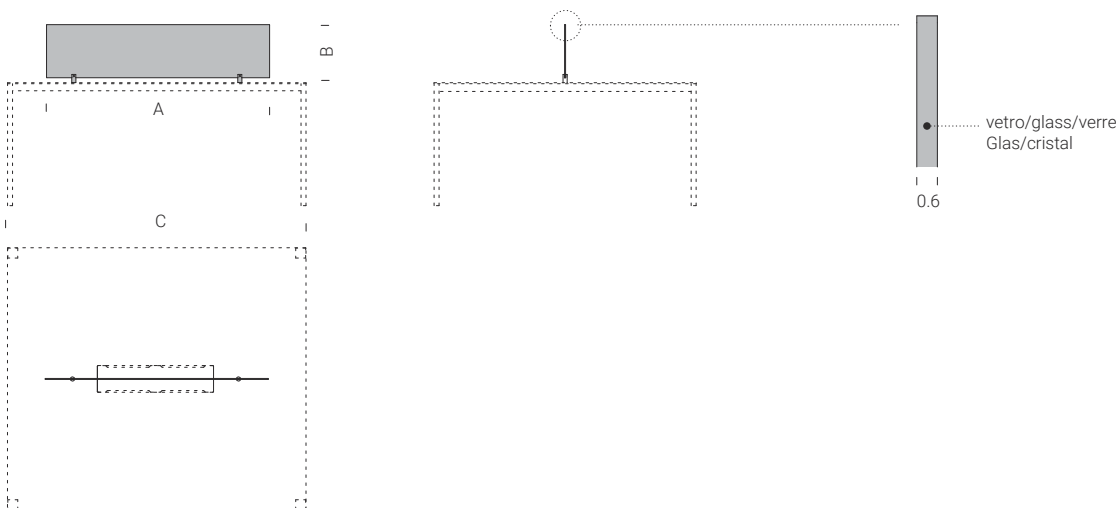

	A x B	C	Q
OACC0011	100 x 35	120/140	176
OACC0008	140 x 35	160/180	218

C acciaio verniciato/painted steel/acier peint
lackierter Stahl/acero pintado

C12 bianco/white	C18 verde/green
C21 seta/silk	C26 corten/corten
C23 corda/ecru	C29 bronzo/bronze
C30 ghisa/cast-iron	C37 rame/copper
C14 antracite/anthracite	C38 titanio/titanium
C08 nero/black	

C acciaio verniciato/painted steel/acier peint
lackierter Stahl/acero pintado

C12 bianco/white
C08 nero/black

MODESTY PANEL / MODESTY PANEL / PANNEAU DE FOND / MODESTY PANEL / PANEL MODESTIA

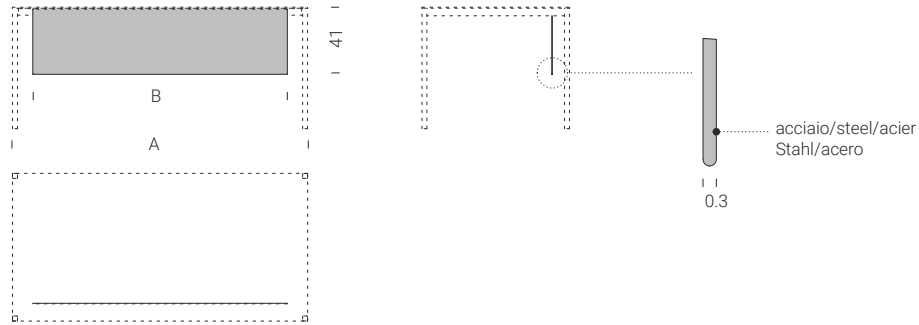

	B x C x D (A)	C
OACC0005	113 x 41 x 0.3 (140)	269
OACC0006	133 x 41 x 0.3 (160)	298
OACC0007	153 x 41 x 0.3 (180)	340

PORTA PC CON CASSETTO / PC HOLDER WITH DRAWER / SUPPORT PC AVEC TIROIR / PC-HALTER MIT SCHUBLADE / SOPORTE PARA PC CON CAJÓN

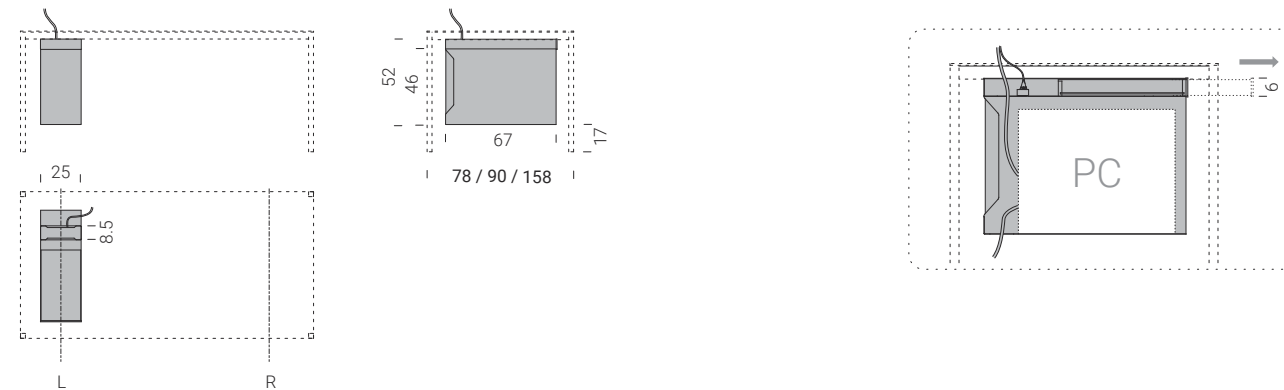

	C
OACC0009	444

solo per tavoli da 78/90/158.
only for 78/90/158 wide tables.
uniquement pour les tables longues 78/90/158.
nur für Tische mit einer Länge von 78/90/158.
solo para mesas largas 78/90/158.

ordinabile in posizione L (sinistra), R (destra).
available in the following positions: L (left), R (right).
peut être commandé en position L (gauche), R (droite).
aufstellbar in Position L (links), R (rechts).
disponible en posición L (izquierda), R (derecha).

scocca in acciaio e frontale cassetto nelle finiture del tavolo. (il prezzo include la foratura del top tavolo).
Steel body and drawer front in the table finishings. (the price includes perforation of the table top).
coque en acier et façade de tiroir dans les mêmes finitions que la table. (le prix inclut le perçage du plateau de la table).
Stahlaufbau und Schubladenfront in den Tischausführungen. (Die Bohrung der Tischplatte ist im Preis inbegriffen).
chapa de acero y frontal de cajón en los acabados de la mesa. (el precio incluye el perforado de la encimera).

CASSETTIERA / CHEST OF DRAWERS / COMMODOE / KOMMODE / CAJONERA

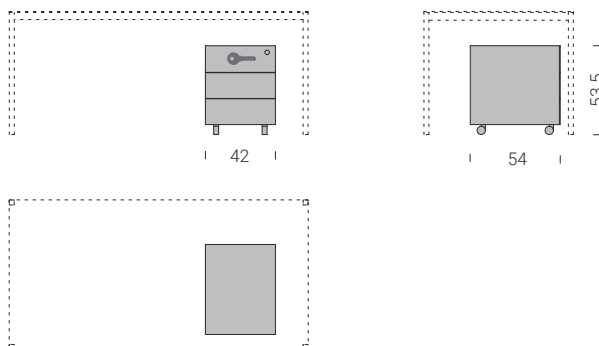

	C08 C12
OACC0010	426

C acciaio verniciato/painted steel/acier peint
lackierter Stahl/acero pintado

- | | |
|---------------------------------|-----------------------------|
| C12 bianco/white | C18 verde/green |
| C21 seta/silk | C26 corten/corten |
| C23 corda/ecru | C29 bronzo/bronze |
| C30 ghisa/cast-iron | C37 rame/copper |
| C14 antracite/anthracite | C38 titanio/titanium |
| C08 nero/black | |

**CASSETTO CON PASSACAVO / DRAWER WITH CABLE GLAND / TIROIR AVEC PASSE-CÂBLE
SCHUBLADE MIT KABELDURCHLASS / CAJÓN CON PASACABLES**

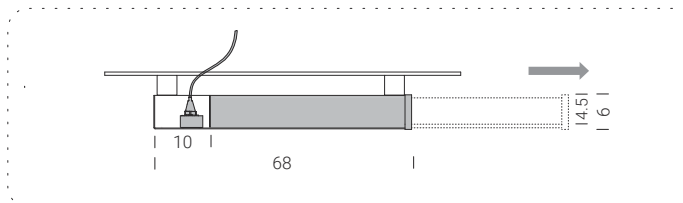
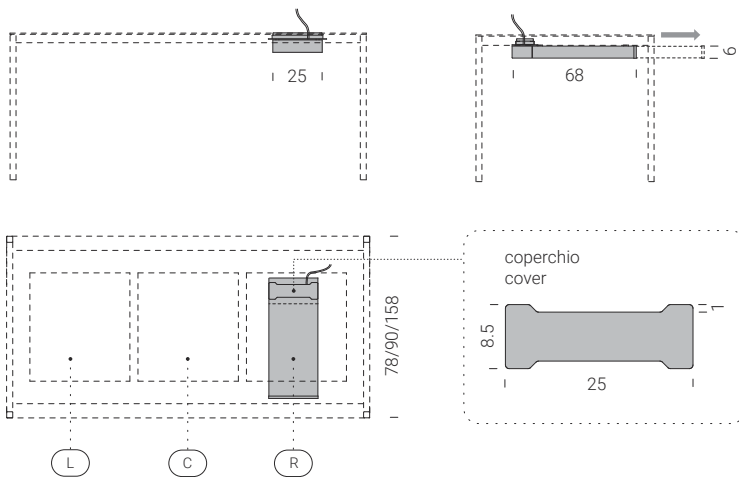

	A x B x C	C
OACC0013	68 x 25 x 6	312

vedi catalogo a pg.200
refer to catalogue pg.200
Voir catalogue pg. 200
siehe Katalog auf pg.200
véase pg.200 del catálogo

scocca in acciaio e frontale nelle finiture del tavolo. (il prezzo include la foratura del top tavolo).
Steel body and front in the table finishings. (the price includes perforation of the table top).
coque en acier et façade dans les mêmes finitions que la table. (le prix inclut le perçage du plateau de la table).
Stahlaufbau und Vorderseite in den Tischausführungen. (Die Bohrung der Tischplatte ist im Preis inbegriffen).
chapa de acero y frontal en los acabados de la mesa. (el precio incluye el perforado de la encimera).

ordinabile in posizione L (sinistra), R (destra), C (centrale).
available in the following positions: L (left), R (right), C (central).
peut être commandé en position L (gauche), R (droite), C (centrale).
aufstellbar in Position L (links), R (rechts), C (Mitte).
disponible en posición L (izquierda), R (derecha), C (central).

**VERDE INTEGRATO / INTEGRATED GREEN / VERT INTÉGRÉ
GRÜN INTEGRIERT / VERDE INTEGRADO**

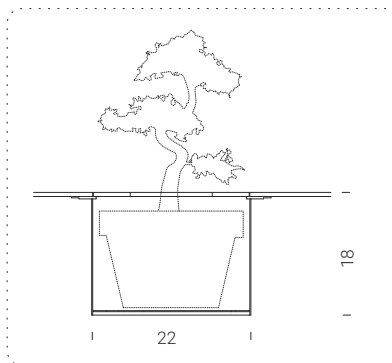
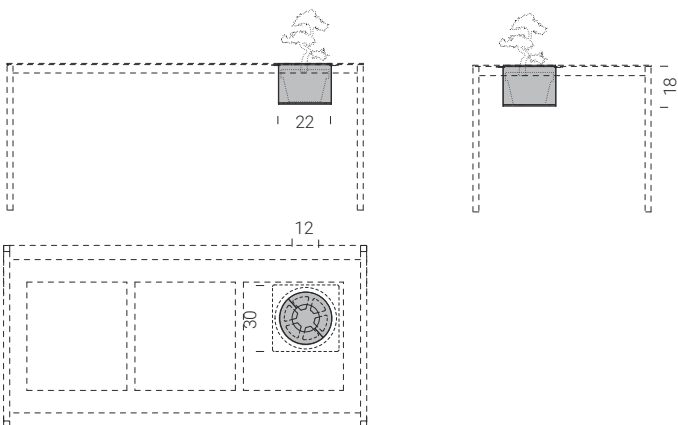

	C
OACC0004	252

cesto in acciaio e copertura nelle finiture del tavolo.(il prezzo include la foratura del top tavolo).
steel basket and cover in the table finishings. (the price includes perforation of the table top).
panier en acier et couvercle dans les mêmes finitions que la table. (le prix inclut le perçage du plateau de la table).
Stahlkorb und Abdeckung in der Tischausführung.(Die Bohrung der Tischplatte ist im Preis inbegriffen).
cesto de acero y cubierta en los acabados de la mesa.(el precio incluye el perforado de la encimera).

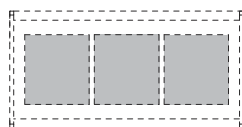

può essere posizionato esclusivamente nelle aree evidenziate.
it can be placed only in the highlighted areas.
il peut être placé que dans le domaines mis en évidence.
es kann nur in den hervorgehobenen Bereichen angeordnet werden.
se puede colocar sólo en las áreas resaltadas.

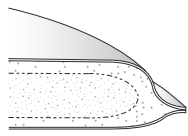

cuoio/cow-hide/cuir
Kernleder/cuero

F01 tabacco/tobacco
F02 nero/black



ceramica/ceramic/c ramique
Keramik/cer mico

S05 antracite/anthracite
S06 nero/black
S07 porfido/porfido
S08 cardoso/cardoso



HPL POLARIS®
L03 bianco/white
L10 grigio chiaro/light grey
L11 grigio scuro/dark grey



HPL FENIX®
L08 grigio Londra/London grey
L06 nero/black



HPL+ cemento/concrete/ciment
zement/cemento
D01 bianco calce/lime white
D02 grigio Portland/Portland grey
D03 nero/black



HPL+ metallo/metal/m tal/Metall/metal
C31 ottone/brass
C32 ottone scuro/dark brass
C35 inox/inox
C36 inox scuro/dark inox

**CUSCINO PER PANCA / BENCH CUSHION / COUSSIN POUR BANC
BANKKISSEN / COJ N PARA BANQUILLO**

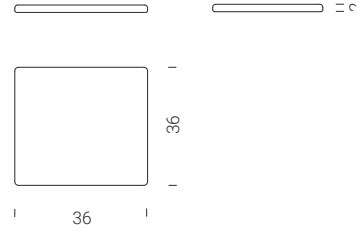
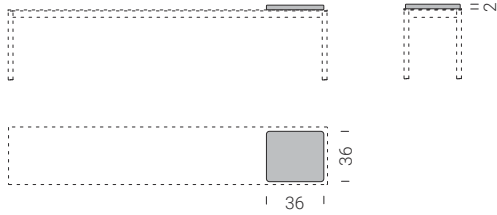

	F01 F02
OACC0001	132

**SCHIENALE CON CUSCINO / BACKREST WITH CUSHION / DOSSIER AVEC COUSSIN
R CKENLEHNE MIT KISSEN / RESPALDO CON COJ N**

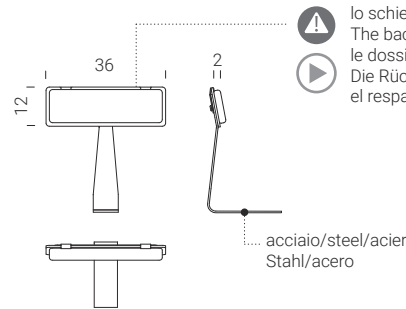
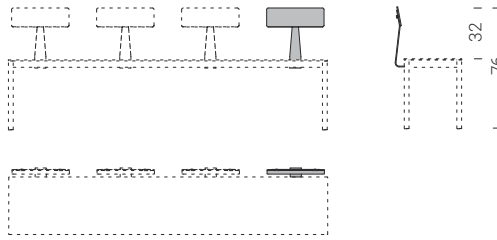

! lo schienale ha le stesse finiture della panca
The backrest has the same finishes as the bench
le dossier a les m mes finitions que le banc
Die R ckenlehne wird wie die Bank vollendet
el respaldo tiene los mismos acabados que el banco

	F01 F02
OACC0002	232

cuscino incluso
cushion included
coussin inclus
kissen enthalten
cojin incluido

VASSOI / TRAYS / PLATEAUX / TABLETS / BANDEJAS

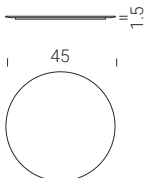

		S05 S06 S07 S08	L03 L06	L08 L10 L11	D01 D02 D03	C31 C32 C35 C36
SACC0007	45 x 1.5	190	165	180	205	245

vedi catalogo a pg.172 / refer to catalogue pg.172
Voir catalogue pg. 172 / siehe Katalog auf pg.172
v ase pg.172 del cat logo

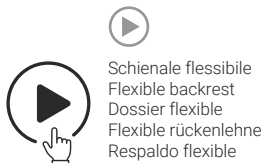

Schienale flessibile
Flexible backrest
Dossier flexible
Flexible r ckenlehne
Respaldo flexible

ST35



AD INTERRUPTERE IL RIGORE DELLA FORMA RETTANGOLARE, LA LIEVE RAGGIATURA AI VERTICI DEL TOP FUNGE DA RACCORDO GEOMETRICO TRA ESSO E LA BASE IN ACCIAIO, E CONFERISCE AL TAVOLO ARMONIA E COMPATTEZZA DI FORMA. ST35 È DISPONIBILE IN VERSIONE FISSA E ALLUNGABILE; PER LA VERSIONE FISSA SONO DISPONIBILI 8 CATEGORIE DI FINITURE TOP, MENTRE PER I BASAMENTI LA SCELTA È TRA 11 COLORAZIONI A POLVERI.

Interrupting the rigour of the rectangular shape, the slight rounding at the corners of the top acts as a geometric connection between the top and the steel base and makes the table harmonic and compact. ST35, in the fixed and extendible version; for the fixed version there are 8 types of finish available for the top, while for the base there is a choice of 11 powder coated colours.

Pour interrompre la rigueur de la forme rectangulaire, le léger rayonnage aux sommets du plateau agit comme une connexion géométrique entre celui-ci et le socle en acier, conférant harmonie et compacité des formes à la table. ST35 est disponible en version fixe et extensible ; il est possible de choisir parmi 8 catégories de finitions de plateau pour la version fixe, tandis que 11 couleurs de poudre sont disponibles pour les socles.

Zur Unterbrechung der Strenge der rechteckigen Form dient die leichte Strahlenform an den Enden der Tischplatte als geometrische Verbindung zwischen der Tischplatte und dem Sockel aus Eisen und verleiht dem Tisch Harmonie und Kompaktheit in der Form. ST35 ist in fester und ausdehnbarer Version verfügbar; für die feste Version sind 8 Beschichtungskategorien der Tischplatte verfügbar, während für das Untergestell zwischen 11 Pulverfärbungen gewählt werden kann.

Para interrumpir el rigor de la forma rectangular, el ligero radio de los vértices del tablero actúa como vínculo geométrico entre éste y la base de acero, dando a la mesa armonía y compacidad de formas. La ST35 está disponible en versión fija y extensible; para la versión fija hay 8 categorías de acabados para el tablero, mientras que para la base se puede elegir entre 11 colores con recubrimiento pulverizado.



Disponibili riduzioni a misura
Custom reductions available
Réductions sur mesure disponibles
Verkürzungen auf Maß erhältlich
Disponibles reducciones a medida



Passacavo disponibile per tutti i top
Cable gland available for all tops
Passe-câble disponible pour tous les plateaux
Kabeldurchlass für alle Abschlussborde verfügbar
Pasacables disponible para todos los sobres



Uso in esterno riparato
Use in a sheltered outdoor space
Utilisation en extérieur, en espace abrité
Verwendung in geschütztem Außenbereich
Uso exterior protegido

acciaio verniciato/painted steel/acier peint
lackierter Stahl/acero pintado

C12 bianco/white
C21 seta/silk
C23 corda/ecru
C30 ghisa/cast-iron
C14 antracite/anthracite
C08 nero/black
C18 verde/green
C26 corten/corten
C29 bronzo/bronze
C37 rame/copper
C38 titanio/titanium

ceramica/ceramic/c eramique
Keramik/cer mico

S05 antracite/anthracite
S06 nero/black
S07 porfido/porfido
S08 cardoso/cardoso

HPL POLARIS®

L03 bianco/white
L10 grigio chiaro/light grey
L11 grigio scuro/dark grey

HPL FENIX®

L08 grigio Londra/London grey
L06 nero/black

HPL+ legno/wood/bois/Holz/madera

Y36 rovere/oak
Y34 noce/walnut
Y37 rovere affumicato/smoked oak
Y39 frassino nero/black ash
Y40 frassino argilla/clay ash

TAVOLI ALLUNGABILI / EXTENDABLE TABLES / TABLES EXTENSIBLES
AUSZIEHBARE TISCHE / MESAS EXTENSIBLES

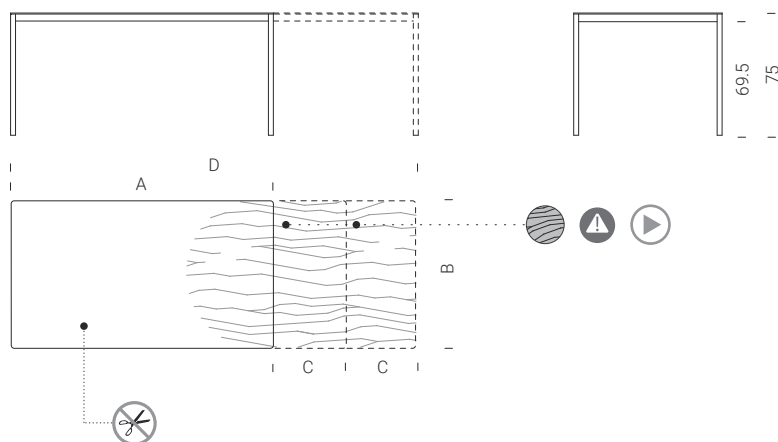

	A / D x B	C		S05 S06 S07 S08	L03 L06	L08 L10 L11	Y36 Y34 Y37 Y39 Y40
3TAV0003	130 / 180 x 78	50	6 (8)	2744	2560	2680	2881
3TAV0001	130 / 180 x 90	50	6 (8)	2966	2775	2914	3131
3TAV0005	160 / 240 x 78	40+40	6 (10)	3222	3007	3167	3402
3TAV0006	160 / 240 x 90	40+40	6 (10)	3552	3265	3449	3704
3TAV0002	200 / 300 x 90	50+50	8 (12)	3814	3631	3800	4077
3TAV0058	200 / 300 x 98	50+50	8 (12)	4119	3922	4104	4404

le allunghe possono essere posizionate all'interno del tavolo.
the extensions can be positioned inside the table.
les rallonges peuvent  tre plac es   l'int rieur de la table.
die Verl ngerungen k nnen innerhalb des Tisches gelegt werden.
las extensiones pueden colocarse dentro de la mesa.

PANCHE ALLUNGABILI / EXTENDABLE BENCHES / BANCS EXTENSIBLES
AUSZIEHBARE B NKE / BANQUILLOS EXTENSIBLES

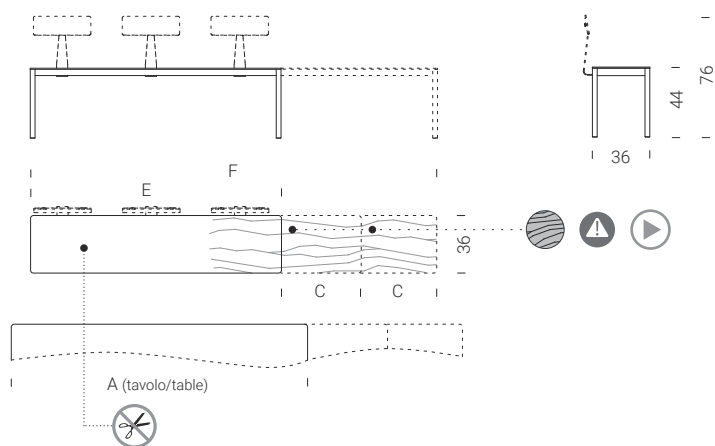

	E / F x 36	C	A		S05 S06 S07 S08	L03 L06	L08 L10 L11	Y36 Y34 Y37 Y39 Y40
3PAN0001	90 / 140 x 36	50	130	2 (3)	1684	1520	1564	1718
3PAN0002	120 / 200 x 36	40+40	160	2 (4)	1886	1702	1752	1924
3PAN0003	160 / 260 x 36	50+50	200	3 (5)	2433	2236	2284	2508

le allunghe possono essere posizionate all'interno del tavolo.
the extensions can be positioned inside the table.
les rallonges peuvent  tre plac es   l'int rieur de la table.
die Verl ngerungen k nnen innerhalb des Tisches gelegt werden.
las extensiones pueden colocarse dentro de la mesa.

schienali e cuscini non inclusi nel prezzo, info pagina 143
backrests and cushions not included in the price, info on page 143
dossiers et coussins non inclus dans le prix, info page 143
R ckenteile und Kissen nicht im Preis inbegriffen, Info Seite 143
respaldos y cojines no incluidos en el precio, p gina de informaci n 143

impiallacciatura continua su top e allunghe
continues veneer on top and extensions
les veines du placage bois suivent sur les rallonges
sauberer Furnierverlauf  ber Tisch- und Verl ngerungsplatte
chapa de madera contin a en el plano y extensiones

top e allunghe nella stessa finitura
top and extensions with the same finish
plateau et rallonges dans la m me finition
Abdeck- und Ausziehplatten in derselben Vollendung
Encimera y extensiones en el mismo acabado

Apertura allunghe
Opening of extensions
Ouverture de rallonges
 ffnung verl ngerungsst cke
Apertura de la extensi n

acciaio verniciato/painted steel/acier peint
lackierter Stahl/acero pintado

- C12 bianco/white
- C21 seta/silk
- C23 corda/ecru
- C30 ghisa/cast-iron
- C14 antracite/anthracite
- C08 nero/black
- C18 verde/green
- C26 corten/corten
- C29 bronzo/bronze
- C37 rame/copper
- C38 titanio/titanium

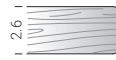

- legno massiccio/solid wood
bois massif/Massivholz
madera maciza
- T01 rovere/oak
 - T02 noce/walnut
 - T03 iroko
 - T04 iroko outdoor
 - T05 rovere nero/black oak

- ceramica/ceramic/c eramique
Keramik/cer mico
- S05 antracite/anthracite
 - S06 nero/black
 - S07 porfido/porfido
 - S08 cardoso/cardoso

- HPL POLARIS®
- L03 bianco/white
 - L10 grigio chiaro/light grey
 - L11 grigio scuro/dark grey
- HPL FENIX®
- L08 grigio Londra/London grey
 - L06 nero/black

- HPL+ cemento/concrete/ciment
zement/cemento
- D01 bianco calce/lime white
 - D02 grigio Portland/Portland grey
 - D03 nero/black
- HPL+ metallo/metal/m tal/Metall/metal
- C31 ottone/brass
 - C32 ottone scuro/dark brass
 - C35 inox/inox
 - C36 inox scuro/dark inox

- HPL+ legno/wood/bois/Holz/madera
- Y36 rovere/oak
 - Y34 noce/walnut
 - Y37 rovere affumicato/smoked oak
 - Y39 frassino nero/black ash
 - Y40 frassino argilla/clay ash
- HPL+ ecotouch
- N01 sabbia/sand
 - N02 basalto/basalt

TAVOLI RETTANGOLARI E QUADRATI / RECTANGULAR AND SQUARE TABLES / TABLES RECTANGULAIRES ET CARR ES
RECHTECKIGE UND QUADRATISCHE TISCHE / MESAS RECTANGULARES Y CUADRADAS

ST35

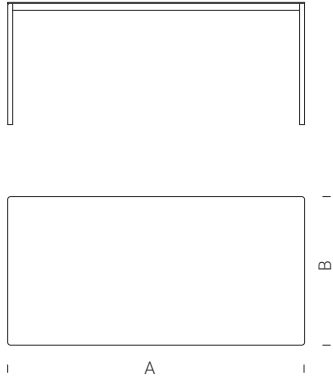

	A x B		T01 T03 T04	T02 T05	S05 S06	S07 S08	L03 L06	L08 L10 L11	D01 D02 D03	C31 C32 C35 C36	Y36 Y34 Y37 Y39 Y40	N01 N02		
3TAV0007	120 x 78	4	2023	2156	1619	1619	1512	1572	1787	2211	1726	1659	1203	+228
3TAV0028	140 x 78	6	2180	2343	1770	1770	1623	1718	1955	2450	1886	1805	1291	+228
3TAV0030	160 x 78	6	2224	2410	1838	1838	1705	1785	2031	2601	1957	1861	1356	+228
3TAV0009	180 x 78	8	2585	2794	1912	1912	1766	1856	2114	2757	2035	1922	1405	+228
3TAV0019	200 x 78	8	2743	2974	2135	2135	1974	2073	2361	3065	2272	2149	1571	+228
3TAV0008	120 x 90	6	2142	2282	1752	1752	1631	1701	1935	2424	1866	1787	1298	+228
3TAV0029	140 x 90	6	2385	2573	1914	1914	1748	1858	2115	2687	2039	1942	1391	+228
3TAV0031	160 x 90	6	2449	2663	1993	1993	1816	1935	2204	2860	2121	2006	1445	+228
3TAV0010	180 x 90	8	2831	3073	2067	2067	1865	2007	2287	3022	2199	2065	1484	+228
3TAV0020	200 x 90	8	3004	3271	2311	2311	2129	2243	2556	3369	2458	2312	1694	+342
3TAV0059	220 x 90	8	3154	3435	2426	2426	2266	2356	2684	3537	2581	2427	1779	+342
3TAV0012	240 x 90	10	3312	3634	2443	2443	2324	2372	2705	3984	2596	2509	1870	+342
3TAV0014	300 x 90	12	3822	4222	2860	2860	2605	2777	3169	4767	3037	2801	2073	+456
3TAV0021	200 x 98	8	3150	3441	2470	2470	2274	2398	2733	3616	2627	2467	1809	+342
3TAV0060	220 x 98	8	3308	3613	2594	2594	2387	2518	2869	3797	2759	2590	1900	+342
3TAV0017	240 x 98	10	3593	3943	2665	2665	2425	2587	2950	4347	2831	2628	1930	+342
3TAV0018	300 x 98	12	4204	4639	3086	3086	2809	2996	3419	5156	3276	3019	2235	+456
3TAV0022	200 x 120	10	3487	3852	2823	-	2533	2741	3090	4882	2990	2622	2015	+342
3TAV0061	220 x 120	10	3662	4044	2964	-	2659	2878	3245	5126	3144	2753	2116	+342
3TAV0023	240 x 120	10	3947	4359	3024	-	2752	2936	3309	5360	3211	2956	2190	+342
3TAV0024	300 x 120	12	4416	4878	3551	-	3218	3448	3884	6059	3768	3447	2561	+456
	A x B													
3TAV0055	78 x 78	2	1577	1681	1263	1263	1169	1226	1387	1737	1344	1283	937	+228
3TAV0056	90 x 90	4	1712	1825	1371	1371	1270	1331	1508	1886	1459	1392	937	+228
3TAV0057	98 x 98	4	1939	2067	1552	1552	1438	1507	1706	2134	1653	1578	1039	+228
3TAV0050	120 x 120	6	2525	2789	2147	-	1958	2085	2352	3220	2287	2176	1559	+228
3TAV0054	140 x 140	8	2925	3389	2879	-	2624	2796	-	-	3066	2762	2088	+456
3TAV0051	158 x 158	8	3367	3719	3359	-	3101	3261	-	-	3574	3372	2467	+456

maggiorazione per esterno riparato solo per surcharge for sheltered outdoor only for majoration pour ext rieur prot g  juste pour Zuschlag f r drau en gesch tzt nur f r aumento para exterior reparado solo para

T04 S05 D01 L03 L08 C35
S06 D02 L06 L10 C36
S07 D03 L11
S08

solo telaio (info pg.99)
frame only (info on pg.99)
seulement b ti (info pg.99)
Ausschlie lich Rahmen (Info pg.99)
solo marco (informaci n pg.99)

accessori non inclusi, disponibili a pg.140
accessories not included, available on pg.140
Accessoires non inclus, disponibles pg.140
Zubeh r nicht inbegriffen, erh ltlich auf pg.140
accesorios no incluidos, disponibles en pg.140

disponibili riduzioni a misura
tailor-made reduction available
disponibles r ductions sur mesure
Verkleinerung nach Kundenwunsch
disponibles reducciones a medida

3RID0001
+240  



- acciaio verniciato/painted steel/acier peint
lackierter Stahl/acero pintado
- C12 bianco/white
 - C21 seta/silk
 - C23 corda/ecru
 - C30 ghisa/cast-iron
 - C14 antracite/anthracite
 - C08 nero/black
 - C18 verde/green
 - C26 corten/corten
 - C29 bronzo/bronze
 - C37 rame/copper
 - C38 titanio/titanium

- legno massiccio/solid wood
bois massif/Massivholz
madera maciza
- T01 rovere/oak
 - T02 noce/walnut
 - T03 iroko
 - T04 iroko outdoor
 - T05 rovere nero/black oak

- ceramica/ceramic/c eramique
Keramik/cer amico
- S05 antracite/anthracite
 - S06 nero/black
 - S07 porfido/porfido
 - S08 cardoso/cardoso

- HPL POLARIS®
- L03 bianco/white
 - L10 grigio chiaro/light grey
 - L11 grigio scuro/dark grey
- HPL FENIX®
- L08 grigio Londra/London grey
 - L06 nero/black

- HPL+ cemento/concrete/ciment
zement/cemento
- D01 bianco calce/lime white
 - D02 grigio Portland/Portland grey
 - D03 nero/black
- HPL+ metallo/metal/m etal/Metall/metal
- C31 ottone/brass
 - C32 ottone scuro/dark brass
 - C35 inox/inox
 - C36 inox scuro/dark inox

- HPL+ legno/wood/bois/Holz/madera
- Y36 rovere/oak
 - Y34 noce/walnut
 - Y37 rovere affumicato/smoked oak
 - Y39 frassino nero/black ash
 - Y40 frassino argilla/clay ash
- HPL+ ecotouch
- N01 sabbia/sand
 - N02 basalto/basalt

PANCHE FISSE / FIXED BENCHES / BANCS FIXES
FESTE B ANKE / BANQUILLOS FIJOS

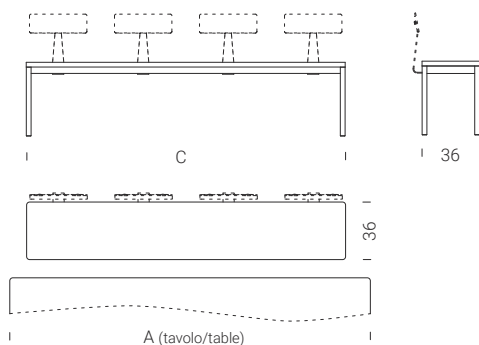

	C x D	A		T01 T03 T04	T02 T05	S05 S06 S07 S08	L03 L06	L08 L10 L11	D01 D02 D03	C31 C32 C35 C36	Y36 Y34 Y37 Y39 Y40	N01 N02		
3PAN0004	90 x 36	120	2	1333	1499	983	954	1045	1172	1543	1124	1064	953	+228
3PAN0005	110 x 36	140	2	1446	1568	1027	997	1093	1225	1613	1176	1113	953	+228
3PAN0006	130 x 36	160	2	1509	1636	1072	1041	1140	1279	1683	1227	1161	953	+228
3PAN0007	150 x 36	180	3	1584	1718	1126	1093	1197	1343	1768	1288	1219	953	+228
3PAN0008	160 x 36	200	3	1627	1764	1156	1122	1229	1379	1815	1323	1252	953	+228
3PAN0012	180 x 36	220	3	1792	1952	1245	1205	1330	1504	2011	1438	1356	953	+228
3PAN0009	200 x 36	240	4	1873	2031	1331	1292	1416	1588	2090	1523	1441	953	+228
3PAN0010	260 x 36	300	5	1992	2152	1445	1405	1530	1704	2211	1638	1556	953	+228

maggiorazione per esterno riparato solo per surcharge for sheltered outdoor only for majoration pour ext erieur prot eg e juste pour Zuschlag f ur drau en gesch utz t nur f ur aumento para exterior reparado solo para

T04 S05 D01 L03 L08 C35
S06 D02 L06 L10 C36
S07 D03 L11
S08

solo telaio (info pg.99)
frame only (info on pg.99)
seulement b ati (info pg.99)
Ausschlie lich Rahmen (Info pg.99)
solo marco (informaci n pg.99)

accessori non inclusi, disponibili a pg.143
accessories not included, available on pg.143
Accessoires non inclus, disponibles pg.143
Zubeh or nicht inbegriffen, erh altlich auf pg.143
accesorios no incluidos, disponibles en pg.143

disponibili riduzioni a misura
tailor-made reduction available
disponibles r eductions sur mesure
Verkleinerung nach Kundenwunsch
disponibles reducciones a medida

3RID0002
+180  



acciaio verniciato/painted steel/acier peint
lackierter Stahl/acero pintado

- C12** bianco/white
- C21** seta/silk
- C23** corda/ecru
- C30** ghisa/cast-iron
- C14** antracite/anthracite
- C08** nero/black
- C18** verde/green
- C26** corten/corten
- C29** bronzo/bronze
- C37** rame/copper
- C38** titanio/titanium



legno massiccio/solid wood
bois massif/Massivholz

- madera maciza**
- T01** rovere/oak
- T02** noce/walnut
- T03** iroko
- T04** iroko outdoor
- T05** rovere nero/black oak

TAVOLI DOGATI / SLATTED TABLES / TABLES À LATTES
DAUBEN-TISCHE / MESAS LAMINADAS

ST35

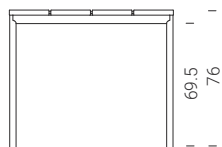
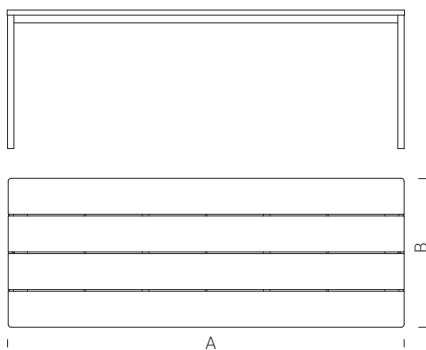

	A x B		T01 T03	T02 T05	 T04
3TAV0032	120 x 78	4	2364	2519	2592
3TAV0034	140 x 78	6	2531	2697	2759
3TAV0036	160 x 78	6	2762	2943	2990
3TAV0038	180 x 78	8	2828	3014	3056
3TAV0040	200 x 78	8	3225	3436	3453
3TAV0033	120 x 90	6	2502	2666	2730
3TAV0035	140 x 90	6	2680	2856	2908
3TAV0037	160 x 90	6	2813	2998	3041
3TAV0039	180 x 90	8	2852	3040	3080
3TAV0041	200 x 90	8	3266	3479	3608
3TAV0064	220 x 90	8	3592	3827	3934
3TAV0044	240 x 90	10	3848	4102	4119
3TAV0047	300 x 90	12	4295	4573	4751
3TAV0042	200 x 98	8	3332	3552	3674
3TAV0066	220 x 98	8	3666	3907	4008
3TAV0045	240 x 98	10	4052	4318	4394
3TAV0048	300 x 98	12	4427	4718	4883
3TAV0043	200 x 120	10	3962	4224	4304
3TAV0068	220 x 120	10	4359	4646	4701
3TAV0046	240 x 120	10	4485	4780	4827
3TAV0049	300 x 120	12	5019	5348	5475

	A x B				
3TAV0062	78 x 78	2	1843	1964	2071
3TAV0063	90 x 90	4	2000	2132	2228
3TAV0065	98 x 98	4	2265	2415	2493
3TAV0067	120 x 120	6	2870	3058	3098
3TAV0073	140 x 140	8	3656	4236	4282
3TAV0074	158 x 158	8	4208	4648	4664



esterno **T04**
outdoor **T04**
extérieur **T04**
draußen **T04**
exterior **T04**



disponibili riduzioni a misura
tailor-made reduction available
disponibles réductions sur mesure
Verkleinerung nach Kundenwunsch
disponibles reducciones a medida

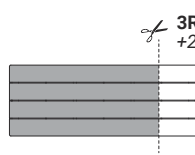

3RID0001
+240 €

- acciaio verniciato/painted steel/acier peint
lackierter Stahl/acero pintado
- C12** bianco/white
 - C21** seta/silk
 - C23** corda/ecru
 - C30** ghisa/cast-iron
 - C14** antracite/anthracite
 - C08** nero/black
 - C18** verde/green
 - C26** corten/corten
 - C29** bronzo/bronze
 - C37** rame/copper
 - C38** titanio/titanium

- legno massiccio/solid wood
bois massif/Massivholz
madera maciza
- T01** rovere/oak
 - T02** noce/walnut
 - T03** iroko
 - T04** iroko outdoor
 - T05** rovere nero/black oak

- ceramica/ceramic/c eramique
Keramik/cer mico
- S05** antracite/anthracite
 - S06** nero/black
 - S07** porfido/porfido
 - S08** cardoso/cardoso

- HPL POLARIS®
- L03** bianco/white
 - L10** grigio chiaro/light grey
 - L11** grigio scuro/dark grey
- HPL FENIX®
- L08** grigio Londra/London grey
 - L06** nero/black

- HPL+ cemento/concrete/ciment
zement/cemento
- D01** bianco calce/lime white
 - D02** grigio Portland/Portland grey
 - D03** nero/black
- HPL+ metallo/metal/m tal/Metall/metal
- C31** ottone/brass
 - C32** ottone scuro/dark brass
 - C35** inox/inox
 - C36** inox scuro/dark inox

- HPL+ legno/wood/bois/Holz/madera
- Y36** rovere/oak
 - Y34** noce/walnut
 - Y37** rovere affumicato/smoked oak
 - Y39** frassino nero/black ash
 - Y40** frassino argilla/clay ash
- HPL+ ecotouch
- N01** sabbia/sand
 - N02** basalto/basalt

**PANCHE DOGATE / SLATTED BENCHES / BANCS   LATTES
DAUBEN-B NKE / BANCOS LAMINADOS**

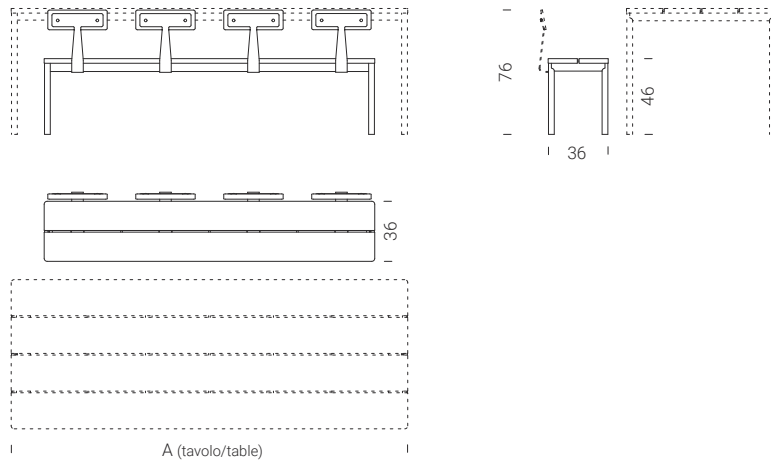

	C x D	A		T01 T03	T02 T05		T04
3PAN0013	90 x 36	120	2	1503	1603		1731
3PAN0014	110 x 36	140	2	1571	1675		1799
3PAN0015	130 x 36	160	2	1639	1748		1867
3PAN0016	150 x 36	180	3	1722	1835		1950
3PAN0017	160 x 36	200	3	1768	1885		1993
3PAN0018	180 x 36	220	3	1945	2073		2173
3PAN0019	200 x 36	240	4	2036	2170		2264
3PAN0020	260 x 36	300	5	2157	2292		2385

SCRITTOI / WRITING DESK / SECR TAIRES/ SCHREIBTISCHEN / ESCRITORIOS

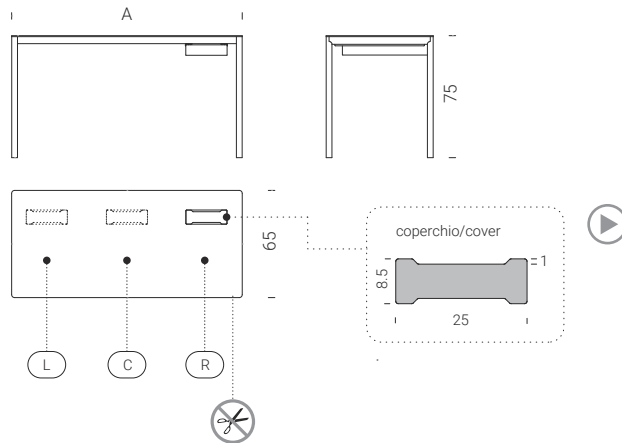

	A x B	T01 T03 T04	T02 T05	S05 S06 S07 S08	L03 L06	L08 L10 L11	D01 D02 D03	C31 C32 C35 C36	Y36 Y34 Y37 Y39 Y40	N01 N02
3TAV0069	100 x 65	2146	2271	1766	1665	1722	1924	2322	1866	1803
3TAV0070	120 x 65	2283	2416	1879	1772	1832	2047	2471	1986	1919
3TAV0071	140 x 65	2440	2603	2030	1883	1978	2215	2710	2146	2065
3TAV0072	160 x 65	2484	2670	2098	1965	2045	2291	2861	2217	2121

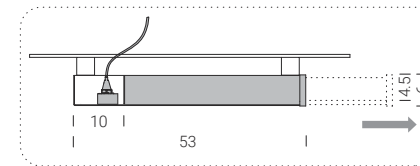

cassetto in acciaio e frontale nelle finiture del tavolo.
steel drawer and front in the table finishings.
tiroir en acier et fa ade dans les m mes finitions que la table.
Stahlschublade und Vorderseite in den Tischausf hrungen.
caj n de acero y frontal en los acabados de la mesa.

esterno **T04**
outdoor **T04**
ext rieur **T04**
drau en **T04**
exterior **T04**

disponibili riduzioni a misura
tailor-made reduction available
disponibles r ductions sur mesure
Verkleinerung nach Kundenwunsch
disponibles reducciones a medida

3RID0002
+180  

ordinabile in posizione C (centrale).
available in the following positions: C (central).
peut  tre command  en position C (centrale).
aufstellbar in Position C (Mitte).
disponible en posici n C (central).

ordinabile in posizione L (sinistra), C (centrale), R (destra).
available in the following positions: L (left), C (central), R (right).
peut  tre command  en position L (gauche), C (centrale), R (droite).
aufstellbar in Position L (links), C (Mitte), R (rechts).
disponible en posici n L (izquierda), C (central), R (derecha).

Passacavi scrittoio
Writing desk cable sleeve
Passe-c bles pour bureau
Kabeldurchgang schreibtisch
Pasacables escritorio

- acciaio verniciato/painted steel/acier peint
lackierter Stahl/acero pintado
- C12** bianco/white
 - C21** seta/silk
 - C23** corda/ecru
 - C30** ghisa/cast-iron
 - C14** antracite/anthracite
 - C08** nero/black
 - C18** verde/green
 - C26** corten/corten
 - C29** bronzo/bronze
 - C37** rame/copper
 - C38** titanio/titanium

- ceramica/ceramic/c eramique
Keramik/cer mico
- S05** antracite/anthracite
 - S06** nero/black
 - S07** porfido/porfido
 - S08** cardoso/cardoso

- HPL POLARIS®
- L03** bianco/white
 - L10** grigio chiaro/light grey
 - L11** grigio scuro/dark grey
- HPL FENIX®
- L08** grigio Londra/London grey
 - L06** nero/black

- HPL+ cemento/concrete/ciment
zement/cemento
- D01** bianco calce/lime white
 - D02** grigio Portland/Portland grey
 - D03** nero/black
- HPL+ metallo/metal/m tal/Metall/metal
- C31** ottone/brass
 - C32** ottone scuro/dark brass
 - C35** inox/inox
 - C36** inox scuro/dark inox

- HPL+ legno/wood/bois/Holz/madera
- Y36** rovere/oak
 - Y34** noce/walnut
 - Y37** rovere affumicato/smoked oak
 - Y39** frassino nero/black ash
 - Y40** frassino argilla/clay ash
- HPL+ ecotouch
- N01** sabbia/sand
 - N02** basalto/basalt

TAVOLI COMPONIBILI / MODULAR TABLES / TABLES MODULABLES KOMPONIERBARE TISCHE / MESAS MODULARES

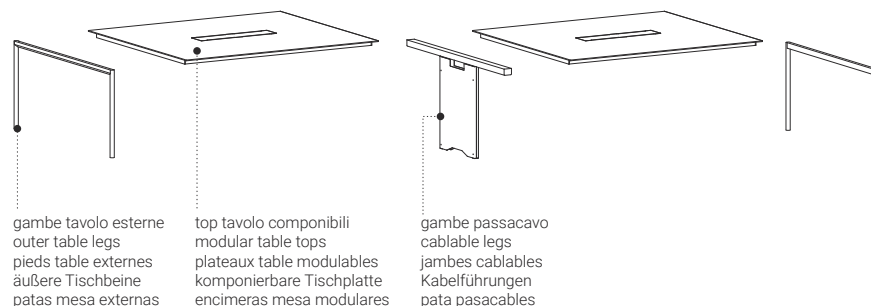
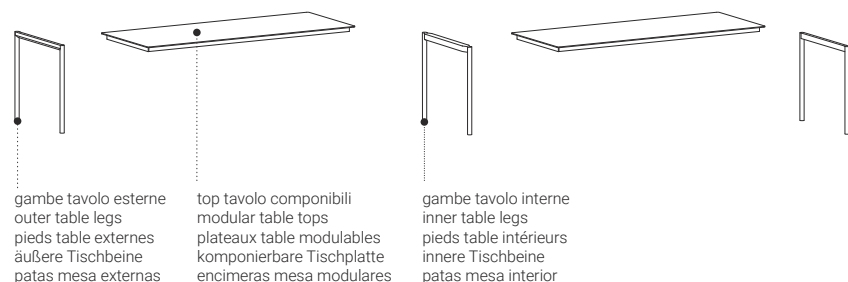

TOP TAVOLO COMPONIBILI / MODULAR TABLE TOPS / PLATEAUX TABLE MODULABLES KOMPONIERBARE TISCHPLATTE / ENCIMERAS MESA MODULARES

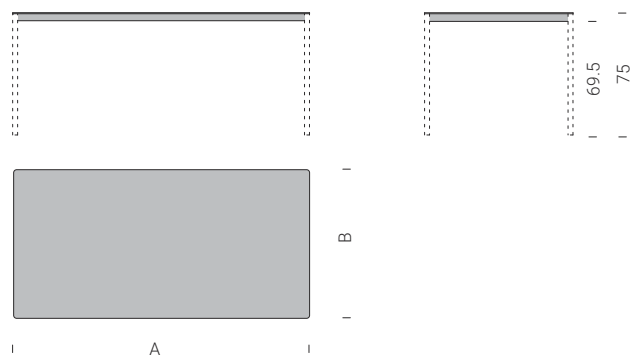

	A x B		S05 S06	S07 S08	L03 L06	L08 L10 L11	D01 D02 D03	C31 C32 C35 C36	Y36 Y34 Y37 Y39 Y40	N01 N02
3TOP0001	120 x 78	4	1061	1061	954	1014	1229	1653	1168	1101
3TOP0002	140 x 78	6	1212	1212	1065	1160	1397	1892	1328	1247
3TOP0003	160 x 78	6	1280	1280	1147	1227	1473	2043	1399	1303
3TOP0004	180 x 78	8	1354	1354	1208	1298	1556	2199	1477	1364
3TOP0005	200 x 78	8	1577	1577	1416	1515	1803	2507	1714	1591
3TOP0006	120 x 120	8	1455	-	1266	1393	1660	2528	1595	1484
3TOP0007	200 x 120	10	2131	-	1841	2049	2398	4190	2398	1930
3TOP0018	220 x 120	10	2272	-	1967	2186	2553	4434	2552	2061
3TOP0008	240 x 120	10	2332	-	2060	2244	2617	4668	2619	2264
3TOP0009	300 x 120	12	2859	-	2526	2756	3192	5367	3076	2755



accessori disponibili a pg.140
accessories available on pg.140
accessoires disponibles pg.140
erh ltliches Zubeh r auf pg.140
accesorios disponibles en pg.140



disponibili riduzioni a misura
tailor-made reduction available
disponibles r ductions sur mesure
Verkleinerung nach Kundenwunsch
disponibles reducciones a medida

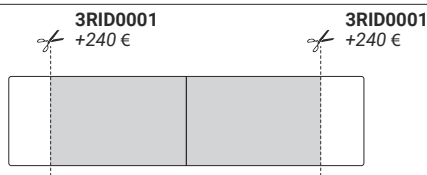

- acciaio verniciato/painted steel/acier peint
lackierter Stahl/acero pintado
- C12 bianco/white
 - C21 seta/silk
 - C23 corda/ecru
 - C30 ghisa/cast-iron
 - C14 antracite/anthracite
 - C08 nero/black
 - C18 verde/green
 - C26 corten/corten
 - C29 bronzo/bronze
 - C37 rame/copper
 - C38 titanio/titanium

- ceramica/ceramic/c eramique
Keramik/cer amico
- S05 antracite/anthracite
 - S06 nero/black
 - S07 porfido/porfido
 - S08 cardoso/cardoso

- HPL POLARIS®
- L03 bianco/white
 - L10 grigio chiaro/light grey
 - L11 grigio scuro/dark grey
- HPL FENIX®
- L08 grigio Londra/London grey
 - L06 nero/black

- HPL+ legno/wood/bois/Holz/madera
- Y36 rovere/oak
 - Y34 noce/walnut
 - Y37 rovere affumicato/smoked oak
 - Y39 frassino nero/black ash
 - Y40 frassino argilla/clay ash
- HPL+ ecotouch
- N01 sabbia/sand
 - N02 basalto/basalt

TOP TAVOLO COMPONENTI / MODULAR TABLE TOPS / PLATEAUX TABLE MODULABLES
KOMPONIERBARE TISCHPLATTE / ENCIMERAS MESA MODULARES

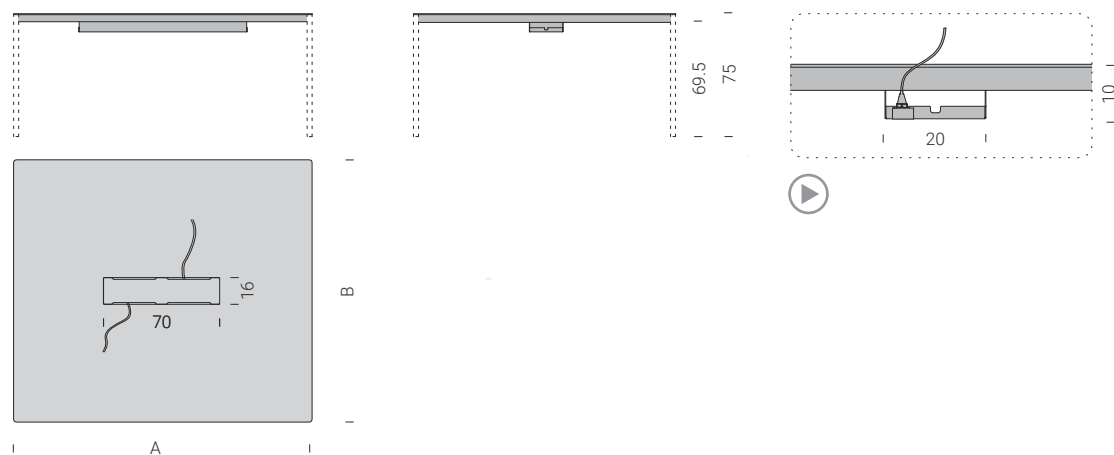

	A x B		S05 S06	S07 S08	L03 L06	L08 L10 L11	Y36 Y34 Y37 Y39 Y40	N01 N02
3TOP0014	120 x 140	8	2252	-	1924	2186	2400	2157
3TOP0015	140 x 140	8	2335	-	1994	2267	2499	2237
3TOP0016	160 x 140	8	2464	-	2104	2392	2624	2360
3TOP0017	180 x 140	10	2636	-	2252	2559	2808	2525
3TOP0010	120 x 158	8	2371	-	2025	2302	2526	2271
3TOP0013	140 x 158	8	2459	-	2100	2387	2620	2355
3TOP0011	160 x 158	8	2594	-	2215	2518	2763	2484
3TOP0012	180 x 158	10	2775	-	2370	2694	2957	2658

GAMBE TAVOLO ESTERNE / OUTER TABLE LEGS / PIEDS TABLE EXTERNES
 U ERE TISCHBEINE / PATAS MESA EXTERNAS

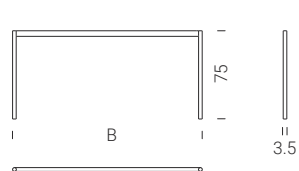

	B x 75	C
3GAM0001	78 x 75	279
3GAM0004	120 x 75	346
3GAM0014	140 x 75	423
3GAM0005	158 x 75	499

GAMBE PASSACAVO / CABLABLE LEGS / JAMBES CABLABLES
KABELF HRUNGEN / PATA PASACABLES

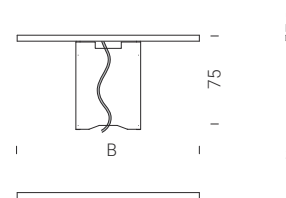

	B x 75	C
OGAM0009	120 x 75	581
OGAM0016	140 x 75	621
OGAM0010	158 x 75	663

GAMBE TAVOLO INTERNE / INNER TABLE LEGS / PIEDS TABLE INT RIEURS
INNERE TISCHBEINE / PATAS MESA INTERIOR

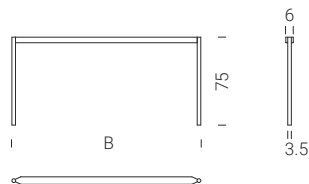

	B x 75	C
3GAM0011	78 x 75	529
3GAM0012	120 x 75	566
3GAM0015	140 x 75	595
3GAM0013	158 x 75	623

accessori disponibili a pg.140
accessories available on pg.140
accessoires disponibles pg.140
erh ltliches Zubeh r auf pg.140
accesorios disponibles en pg.140

Passacavi tavolo studio
Office desk cable sleeve
Passe-c bles pour table de bureau
Kabeldurchgang b rotisch
Pasacables mesa de trabajo

- C** acciaio verniciato/painted steel/acier peint
lackierter Stahl/acero pintado
- C12** bianco/white
 - C21** seta/silk
 - C23** corda/ecru
 - C30** ghisa/cast-iron
 - C14** antracite/anthracite
 - C08** nero/black
 - C18** verde/green
 - C26** corten/corten
 - C29** bronzo/bronze
 - C37** rame/copper
 - C38** titanio/titanium

- Q** vetro laccato/lacquered glass/verre laqué
Glas Lackiert/cristal lacado
- Q05** bianco/white
 - Q16** seta/silk
 - Q17** corda/ecru
 - Q20** ghisa/cast-iron
 - Q14** antracite/anthracite
 - Q04** nero/black
 - Q21** bronzo/bronze

PASSACAVO / CABLE GLAND / PASSE-CÂBLE / KABELDURCHGLASS / PASACABLES

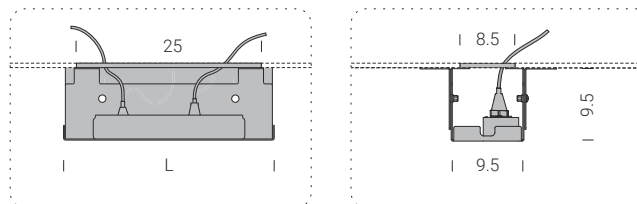
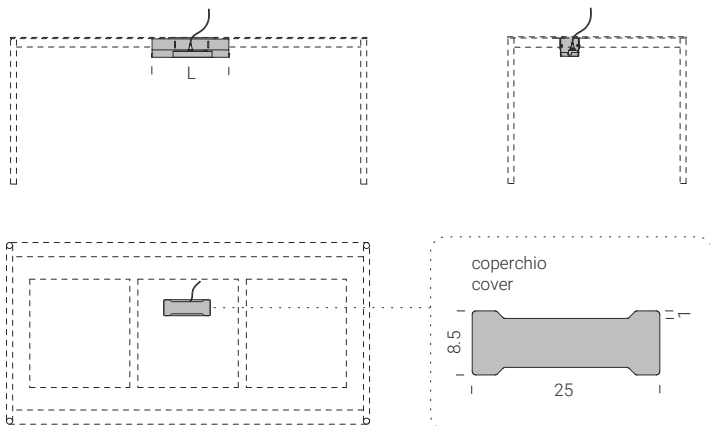

cesto in acciaio e copertura magnetica nelle finiture del tavolo.
steel basket and magnetic cover in the table finishings.
panier en acier et couvercle magnétique dans les mêmes finitions que la table.
Stahlkorb und Magnetabdeckung in der Tischausführung.
cesto de acero y cubierta magnética en los acabados de la mesa.

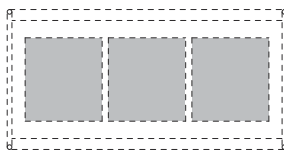

Il passacavi può essere posizionato esclusivamente nelle aree evidenziate.
the cable tidy can be placed only in the highlighted areas
le passe-câbles peut être placé que dans le domaines mis en évidence
das Kabeldurchführung kann nur in den hervorgehobenen Bereichen angeordnet werden
el pasacables se puede colocar sólo en las áreas resaltadas

	L	C
SACC0003	28	185
SACC0004	40	205

vedi catalogo a pg.156
refer to catalogue pg.156
Voir catalogue pg. 156
siehe Katalog auf pg.156
véase pg.156 del catálogo

PRIVACY PANEL / PRIVACY PANEL / PANNEAU DE SÉPARATION / PRIVACY PANEL / PANEL PRIVACIDAD

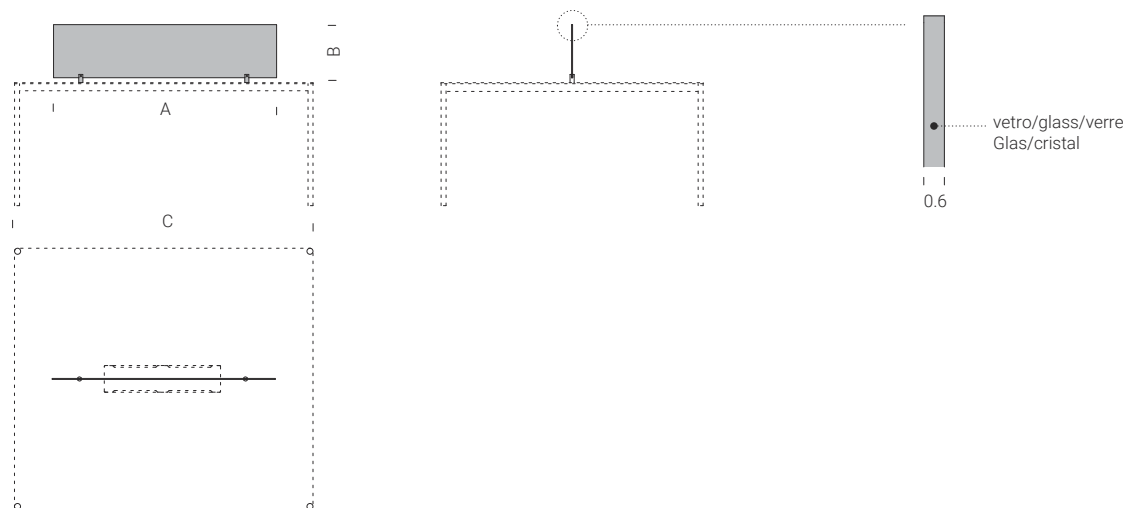

	A x B	C	Q
OACC0011	100 x 35	120/140	176
OACC0008	140 x 35	160/180	218

C acciaio verniciato/painted steel/acier peint
lackierter Stahl/acero pintado

C12 bianco/white
C21 seta/silk
C23 corda/ecru
C30 ghisa/cast-iron
C14 antracite/anthracite
C08 nero/black

C18 verde/green
C26 corten/corten
C29 bronzo/bronze
C37 rame/copper
C38 titanio/titanium

C acciaio verniciato/painted steel/acier peint
lackierter Stahl/acero pintado

C12 bianco/white
C08 nero/black

MODESTY PANEL / MODESTY PANEL / PANNEAU DE FOND / MODESTY PANEL / PANEL MODESTIA

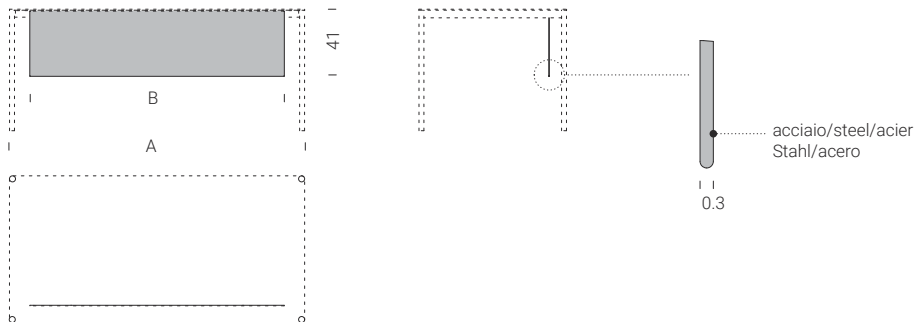

	B x C x D (A)	C
OACC0005	113 x 41 x 0.3 (140)	269
OACC0006	133 x 41 x 0.3 (160)	298
OACC0007	153 x 41 x 0.3 (180)	340

PORTA PC CON CASSETTO / PC HOLDER WITH DRAWER / SUPPORT PC AVEC TIROIR / PC-HALTER MIT SCHUBLADE / SOPORTE PARA PC CON CAJÓN

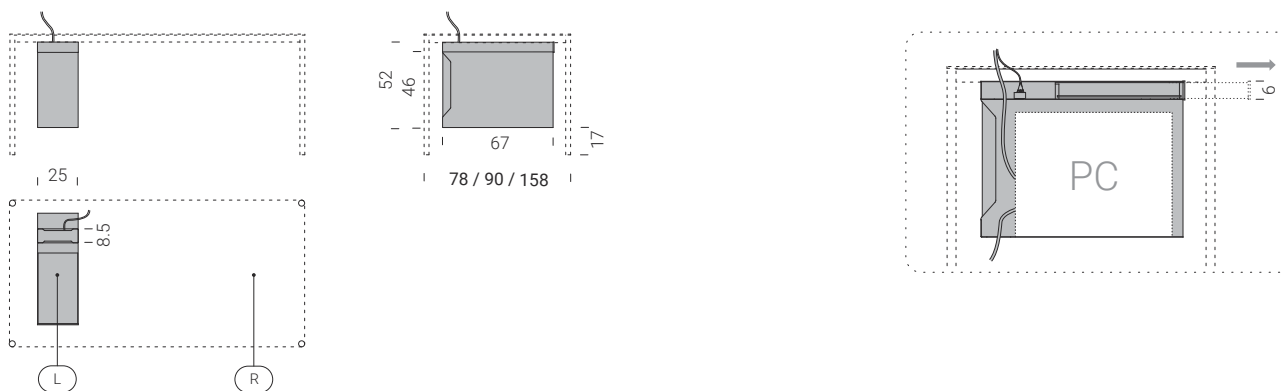

	C
OACC0009	444

solo per tavoli da 78/90/158.
only for 78/90/158 wide tables.
uniquement pour les tables longues 78/90/158.
nur für Tische mit einer Länge von 78/90/158.
solo para mesas largas 78/90/158.

ordinabile in posizione L (sinistra), R (destra).
available in the following positions: L (left), R (right).
peut être commandé en position L (gauche), R (droite).
aufstellbar in Position L (links), R (rechts).
disponible en posición L (izquierda), R (derecha).

scocca in acciaio e frontale cassetto nelle finiture del tavolo. (il prezzo include la foratura del top tavolo).
Steel body and drawer front in the table finishings. (the price includes perforation of the table top).
coque en acier et façade de tiroir dans les mêmes finitions que la table. (le prix inclut le perçage du plateau de la table).
Stahlaufbau und Schubladenfront in den Tischausführungen. (Die Bohrung der Tischplatte ist im Preis inbegriffen).
chapa de acero y frontal de cajón en los acabados de la mesa. (el precio incluye el perforado de la encimera).

CASSETTIERA / CHEST OF DRAWERS / COMMUNE / KOMMODE / CAJONERA

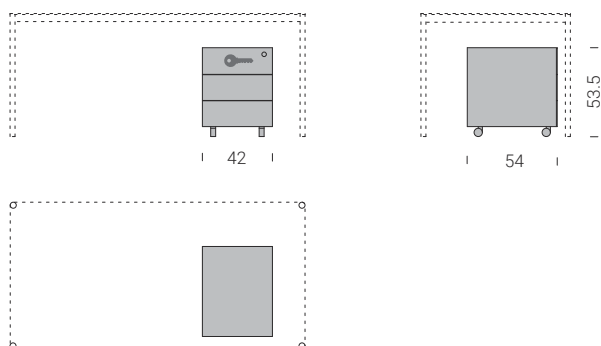

	C08 C12
OACC0010	426



C acciaio verniciato/painted steel/acier peint
lackierter Stahl/acero pintado

- | | |
|---------------------------------|-----------------------------|
| C12 bianco/white | C18 verde/green |
| C21 seta/silk | C26 corten/corten |
| C23 corda/ecru | C29 bronzo/bronze |
| C30 ghisa/cast-iron | C37 rame/copper |
| C14 antracite/anthracite | C38 titanio/titanium |
| C08 nero/black | |

**CASSETTO CON PASSACAVO / DRAWER WITH CABLE GLAND / TIROIR AVEC PASSE-CÂBLE
SCHUBLADE MIT KABELDURCHLASS / CAJÓN CON PASACABLES**

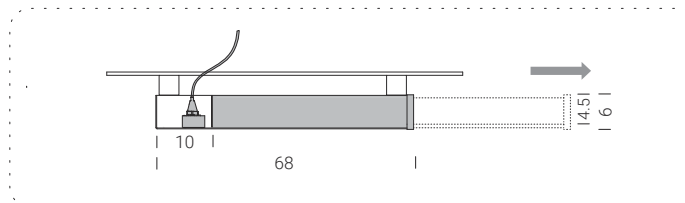
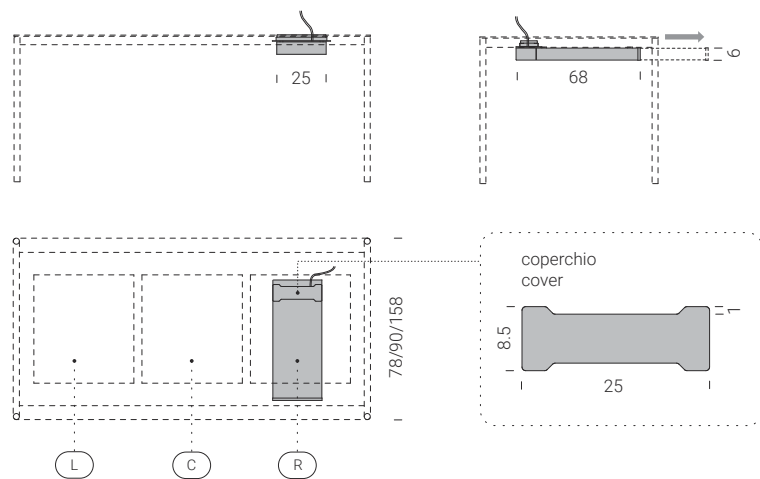

	A x B x C	C
OACC0013	68 x 25 x 6	312

vedi catalogo a pg.200
refer to catalogue pg.200
Voir catalogue pg.200
siehe Katalog auf pg.200
véase pg.200 del catálogo

scocca in acciaio e frontale nelle finiture del tavolo. (il prezzo include la foratura del top tavolo).
Steel body and front in the table finishings. (the price includes perforation of the table top).
coque en acier et façade dans les mêmes finitions que la table. (le prix inclut le perçage du plateau de la table).
Stahlaufbau und Vorderseite in den Tischausführungen. (Die Bohrung der Tischplatte ist im Preis inbegriffen).
chapa de acero y frontal en los acabados de la mesa. (el precio incluye el perforado de la encimera).

ordinabile in posizione L (sinistra), R (destra), C (centrale).
available in the following positions: L (left), R (right), C (central).
peut être commandé en position L (gauche), R (droite), C (centrale).
aufstellbar in Position L (links), R (rechts), C (Mitte).
disponible en posición L (izquierda), R (derecha), C (central).

**VERDE INTEGRATO / INTEGRATED GREEN / VERT INTÉGRÉ
GRÜN INTEGRIERT / VERDE INTEGRADO**

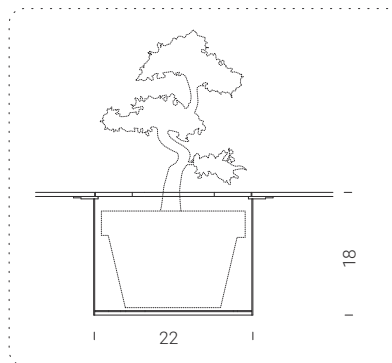
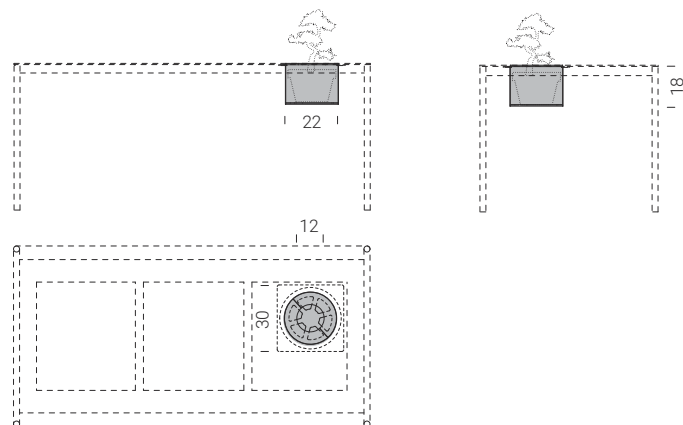

	C
OACC0004	252

cesto in acciaio e copertura nelle finiture del tavolo.(il prezzo include la foratura del top tavolo).
steel basket and cover in the table finishings. (the price includes perforation of the table top).
panier en acier et couvercle dans les mêmes finitions que la table. (le prix inclut le perçage du plateau de la table).
Stahlkorb und Abdeckung in der Tischausführung.(Die Bohrung der Tischplatte ist im Preis inbegriffen).
cesto de acero y cubierta en los acabados de la mesa.(el precio incluye el perforado de la encimera).

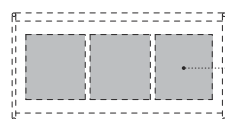

può essere posizionato esclusivamente nelle aree evidenziate.
it can be placed only in the highlighted areas.
il peut être placé que dans le domaines mis en évidence.
es kann nur in den hervorgehobenen Bereichen angeordnet werden.
se puede colocar sólo en las áreas resaltadas.

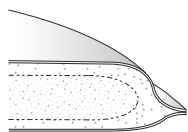

cuoio/cow-hide/cuir
Kernleder/cuero

F01 tabacco/tobacco
F02 nero/black

ceramica/ceramic/c ramique
Keramik/cer mico
S05 antracite/anthracite
S06 nero/black
S07 porfido/porfido
S08 cardoso/cardoso

HPL POLARIS®
L03 bianco/white
L10 grigio chiaro/light grey
L11 grigio scuro/dark grey

HPL FENIX®
L08 grigio Londra/London grey
L06 nero/black

HPL+ cemento/concrete/ciment
zement/cemento
D01 bianco calce/lime white
D02 grigio Portland/Portland grey
D03 nero/black

HPL+ metallo/metal/m tal/Metall/metal
C31 ottone/brass
C32 ottone scuro/dark brass
C35 inox/inox
C36 inox scuro/dark inox

**CUSCINO PER PANCA / BENCH CUSHION / COUSSIN POUR BANC
BANKKISSEN / COJ N PARA BANQUILLO**

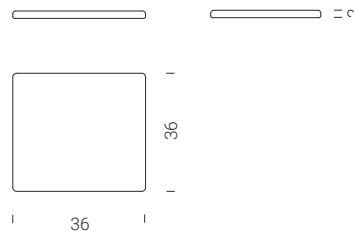
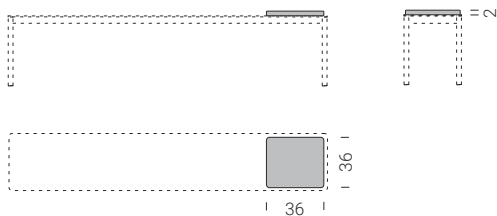

	F01 F02
OACC0001	132

**SCHIENALE CON CUSCINO / BACKREST WITH CUSHION / DOSSIER AVEC COUSSIN
R CKENLEHNE MIT KISSEN / RESPALDO CON COJ N**

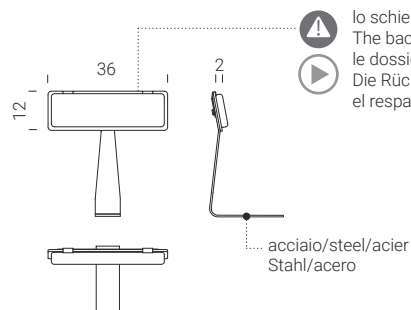
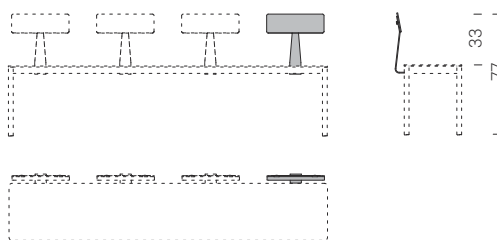

! lo schienale ha le stesse finiture della panca
The backrest has the same finishes as the bench
le dossier a les m mes finitions que le banc
Die R ckenlehne wird wie die Bank vollendet
el respaldo tiene los mismos acabados que el banco

	F01 F02
OACC0002	232

cuscino incluso
cushion included
coussin inclus
kissen enthalten
cojin incluido

VASSOI / TRAYS / PLATEAUX / TABLETS / BANDEJAS

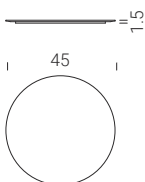

		S05 S06 S07 S08	L03 L06	L08 L10 L11	D01 D02 D03	C31 C32 C35 C36
SACC0007	45 x 1.5	190	165	180	205	245

vedi catalogo a pg.172 / refer to catalogue pg.172
Voir catalogue pg. 172 / siehe Katalog auf pg.172
v ase pg.172 del cat logo

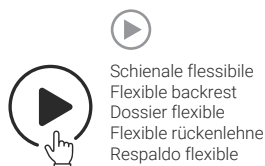

Schienale flessibile
Flexible backrest
Dossier flexible
Flexible r ckenlehne
Respaldo flexible

IPE



UNA COLLEZIONE PROGETTATA PER COSTRUIRE TAVOLI DI GRANDI DIMENSIONI, LA SEZIONE AD IPE IN ACCIAIO UTILIZZATA PER IL SUPPORTO DEI TOP TAVOLI CONFERISCE GRANDE RIGIDITÀ E CONSENTE DI NASCONDERE I CAVI DI ALIMENTAZIONE DI UNITÀ MULTIMEDIALI DAL TOP ALLA PARTE INFERIORE DEL SUPPORTO. I TOP POSSONO ESSERE ACCOSTATI PER DARE VITA AD UN SISTEMA TAVOLI CON DIMENSIONI A PROGETTO.

This is a collection that has been designed in order to create large tables, the IPE section in steel used to support the table tops provides great sturdiness and allows the power cables from multimedia devices to be concealed from the top to the bottom of the support. The table tops can be combined in order to give life to a custom-sized table system.

Une collection conçue pour construire des tables de grandes dimensions, la section en IPE d'acier utilisée pour le support des plateaux de table fournit une grande rigidité et permet de cacher les câbles d'alimentation d'unités multimédias, du plateau à la partie inférieure du support. Les plateaux peuvent être combinés pour créer un système de tables avec des dimensions selon le projet.

Bei unserer Kollektion von großflächigen, stabilen Tischen werden IPE-Stahlprofile als Stütze für die Tischplatte verwendet, denn sie gewährleisten eine ausgezeichnete Standfestigkeit und ermöglichen zudem eine versteckte Kabelführung von multimedialen Geräten auf der Platte bis zum unteren Teil des Gestells. Die Platten können aneinandergeschoben und kombiniert werden, um ein beliebig großes Tischsystem zu kreieren.

Una colección diseñada para construir mesas de gran tamaño: el perfil IPE de acero utilizado para el soporte de las encimeras de las mesas, ofrece una rigidez considerable y permite ocultar los cables de alimentación de unidades multimedia desde la encimera hasta la parte inferior del soporte. Las encimeras pueden colocarse una al lado de la otra para generar un sistema de mesas con tamaños conformes a diseño.



Disponibili riduzioni a misura
Custom reductions available
Réductions sur mesure disponibles
Verkürzungen auf Maß erhältlich
Disponibles reducciones a medida



Passacavo disponibile per tutti i top
Cable gland available for all tops
Passe-câble disponible pour tous les plateaux
Kabeldurchlass für alle Abschlussborde verfügbar
Pasacables disponible para todos los sobres



Possibilità di affiancamento
Possibility to place by side
Possibilité d'association
Aufstellung nebeneinander möglich
Posibilidad de colocarse uno al lado del otro

- acciaio verniciato/painted steel/acier peint
lackierter Stahl/acero pintado
- C12** bianco/white
 - C21** seta/silk
 - C23** corda/ecru
 - C30** ghisa/cast-iron
 - C14** antracite/anthracite
 - C08** nero/black
 - C18** verde/green
 - C26** corten/corten
 - C29** bronzo/bronze
 - C37** rame/copper
 - C38** titanio/titanium

- ceramica/ceramic/c eramique
Keramik/cer mico
- S05** antracite/anthracite
 - S06** nero/black
 - S07** porfido/porfido
 - S08** cardoso/cardoso

- HPL POLARIS®
- L03** bianco/white
 - L10** grigio chiaro/light grey
 - L11** grigio scuro/dark grey
- HPL FENIX®
- L08** grigio Londra/London grey
 - L06** nero/black

- HPL+ cemento/concrete/ciment
zement/cemento
- D01** bianco calce/lime white
 - D02** grigio Portland/Portland grey
 - D03** nero/black
- HPL+ metallo/metal/m tal/Metall/metal
- C31** ottone/brass
 - C32** ottone scuro/dark brass
 - C35** inox/inox
 - C36** inox scuro/dark inox

- HPL+ legno/wood/bois/Holz/madera
- Y36** rovere/oak
 - Y34** noce/walnut
 - Y37** rovere affumicato/smoked oak
 - Y39** frassino nero/black ash
 - Y40** frassino argilla/clay ash
- HPL+ ecotouch
- N01** sabbia/sand
 - N02** basalto/basalt

TAVOLI RETTANGOLARI / RECTANGULAR TABLES / TABLES RECTANGULAIRES
RECHTECKIGE TISCHE / MESAS RECTANGULARES

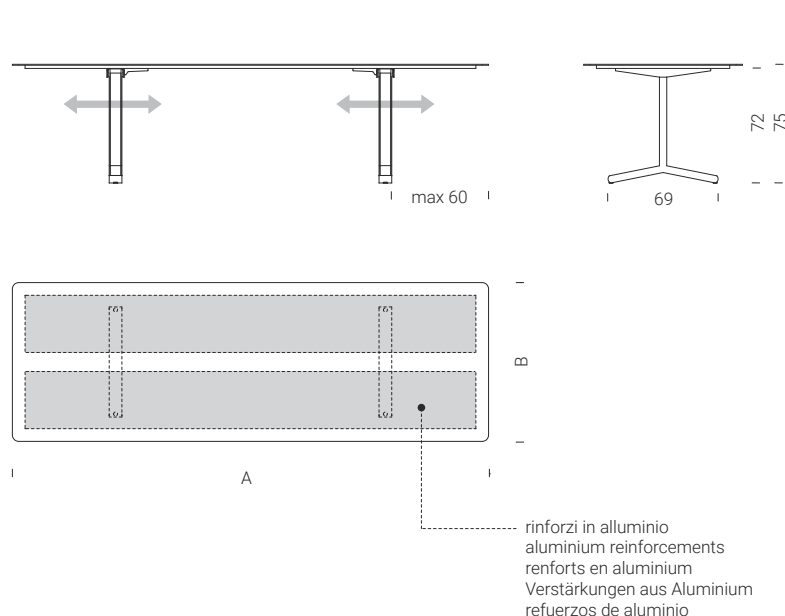

	A x B		S05 S06	S07 S08	L03 L06	L08 L10 L11	D01 D02 D03	C31 C32 C35 C36	Y36 Y34 Y37 Y39 Y40	N01 N02	
UTAV0001	180 x 90	8	3406	3406	2937	3142	3436	4552	3377	3083	+315
UTAV0002	200 x 90	8	3636	3636	3134	3354	3667	4858	3605	3291	+315
UTAV0004	220 x 90	8	3795	3795	3272	3501	3828	5072	3763	3436	+315
UTAV0007	240 x 90	10	3980	3980	3431	3671	4014	5318	3946	3603	+315
UTAV0010	260 x 90	10	4150	4150	3577	3828	4185	5545	4114	3756	+385
UTAV0013	280 x 90	12	4334	4334	3736	3998	4371	5791	4297	3923	+385
UTAV0016	300 x 90	12	4539	4539	3913	4186	4578	6065	4499	4108	+385
UTAV0003	200 x 100	8	3641	3641	3139	3358	3672	4865	3609	3296	+315
UTAV0005	220 x 100	8	3800	3800	3276	3506	3833	5078	3768	3440	+315
UTAV0008	240 x 100	10	3985	3985	3435	3676	4019	5325	3951	3607	+315
UTAV0011	260 x 100	10	4170	4170	3594	3846	4205	5571	4134	3774	+385
UTAV0014	280 x 100	12	4354	4354	3754	4016	4392	5818	4317	3941	+385
UTAV0017	300 x 100	12	4554	4554	3925	4200	4593	6085	4514	4122	+385
UTAV0006	220 x 120	8	3820	-	3293	3524	3853	5105	3787	3458	+315
UTAV0009	240 x 120	10	4005	-	3453	3694	4039	5351	3970	3625	+315
UTAV0012	260 x 120	10	4189	-	3612	3864	4226	5598	4153	3792	+385
UTAV0015	280 x 120	12	4374	-	3771	4035	4412	5845	4336	3959	+385
UTAV0018	300 x 120	12	4583	-	3951	4228	4623	6124	4544	4149	+385
UTAV0019	360 x 120	14	5122	-	4416	4725	-	-	-	4636	+385

maggiorazione per esterno riparato solo per surcharge for sheltered outdoor only for majoration pour ext rieur prot g  juste pour Zuschlag f r drau en gesch tzt nur f r aumento para exterior reparado solo para

- S05 D01 L03 L08 C35
S06 D02 L06 L10 C36
S07 D03 L11
S08

accessori disponibili a pg.148
accessories available on pg.148
accessoires disponibles pg.148
erh ltliches Zubeh r auf pg.148
accesorios disponibles en pg.148

disponibili riduzioni a misura
tailor-made reduction available
disponibles r ductions sur mesure
Verkleinerung nach Kundenwunsch
disponibles reducciones a medida

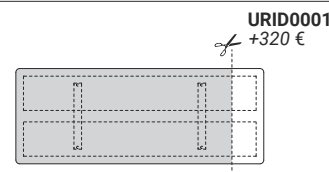

- acciaio verniciato/painted steel/acier peint
lackierter Stahl/acero pintado
- C12 bianco/white
 - C21 seta/silk
 - C23 corda/ecru
 - C30 ghisa/cast-iron
 - C14 antracite/anthracite
 - C08 nero/black
 - C18 verde/green
 - C26 corten/corten
 - C29 bronzo/bronze
 - C37 rame/copper
 - C38 titanio/titanium

- ceramica/ceramic/c eramique
Keramik/cer mico
- S05 antracite/anthracite
 - S06 nero/black
 - S07 porfido/porfido
 - S08 cardoso/cardoso

- HPL POLARIS®
- L03 bianco/white
 - L10 grigio chiaro/light grey
 - L11 grigio scuro/dark grey
- HPL FENIX®
- L08 grigio Londra/London grey
 - L06 nero/black

- HPL+ cemento/concrete/ciment
zement/cemento
- D01 bianco calce/lime white
 - D02 grigio Portland/Portland grey
 - D03 nero/black
- HPL+ metallo/metal/m tal/Metall/metal
- C31 ottone/brass
 - C32 ottone scuro/dark brass
 - C35 inox/inox
 - C36 inox scuro/dark inox

- HPL+ legno/wood/bois/Holz/madera
- Y36 rovere/oak
 - Y34 noce/walnut
 - Y37 rovere affumicato/smoked oak
 - Y39 frassino nero/black ash
 - Y40 frassino argilla/clay ash
- HPL+ ecotouch
- N01 sabbia/sand
 - N02 basalto/basalt

TAVOLI A BOTTE / BARREL VAULT TABLES / TABLES TONNEAU
WEINFASS-TISCHE / MESAS DE BARRIL

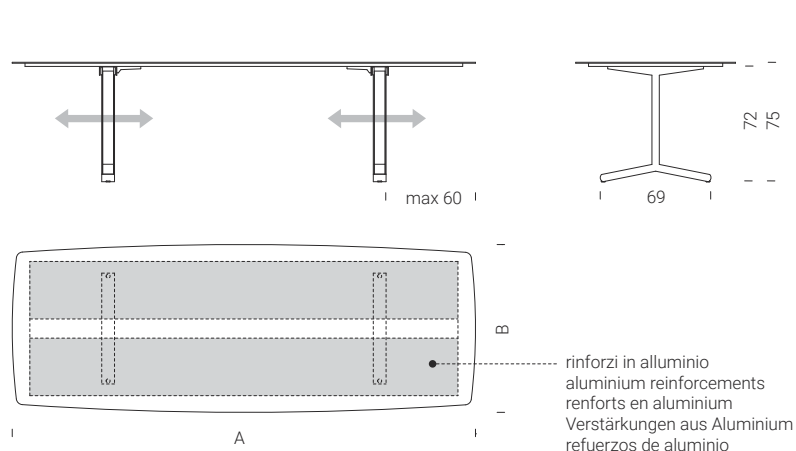

	A x B		S05 S06	S07 S08	L03 L06	L08 L10 L11	D01 D02 D03	C31 C32 C35 C36	Y36 Y34 Y37 Y39 Y40	N01 N02	
UTAV0039	200 x 105	8	3641	3641	3139	3358	3672	4865	3609	3296	+315
UTAV0040	220 x 105	8	3800	3800	3276	3506	3833	5078	3768	3440	+315
UTAV0042	240 x 105	10	3985	3985	3435	3676	4019	5325	3951	3607	+315
UTAV0044	260 x 105	10	4170	4170	3594	3846	4205	5571	4134	3774	+385
UTAV0046	280 x 105	12	4354	4354	3754	4016	4392	5818	4317	3941	+385
UTAV0048	300 x 105	12	4554	4554	3925	4200	4593	6085	4514	4122	+385
UTAV0041	220 x 125	8	3835	-	3306	3538	-	-	3802	3472	+315
UTAV0043	240 x 125	10	4020	-	3465	3708	-	-	3985	3639	+315
UTAV0045	260 x 125	10	4204	-	3625	3878	-	-	4168	3806	+315
UTAV0047	280 x 125	12	4389	-	3784	4048	-	-	4351	3973	+385
UTAV0049	300 x 125	12	4598	-	3964	4242	-	-	4559	4162	+385
UTAV0050	360 x 125	14	5137	-	4429	4739	-	-	-	4650	+385

maggiorazione per esterno riparato solo per surcharge for sheltered outdoor only for majoration pour ext rieur prot g  juste pour Zuschlag f r drau en gesch tzt nur f r aumento para exterior reparado solo para

S05 D01 L03 L08 C35
S06 D02 L06 L10 C36
S07 D03 L11
S08

accessori disponibili a pg.148
accessories available on pg.148
accessoires disponibles pg.148
erh ltliches Zubeh r auf pg.148
accesorios disponibles en pg.148

disponibili riduzioni a misura
tailor-made reduction available
disponibles r ductions sur mesure
Verkleinerung nach Kundenwunsch
disponibles reducciones a medida

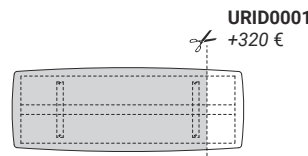

- acciaio verniciato/painted steel/acier peint
lackierter Stahl/acero pintado
- C12 bianco/white
 - C21 seta/silk
 - C23 corda/ecru
 - C30 ghisa/cast-iron
 - C14 antracite/anthracite
 - C08 nero/black
 - C18 verde/green
 - C26 corten/corten
 - C29 bronzo/bronze
 - C37 rame/copper
 - C38 titanio/titanium

- ceramica/ceramic/c eramique
Keramik/cer amico
- S05 antracite/anthracite
 - S06 nero/black
 - S07 porfido/porfido
 - S08 cardoso/cardoso

- HPL POLARIS®
- L03 bianco/white
 - L10 grigio chiaro/light grey
 - L11 grigio scuro/dark grey
- HPL FENIX®
- L08 grigio Londra/London grey
 - L06 nero/black

- HPL+ cemento/concrete/ciment
zement/cemento
- D01 bianco calce/lime white
 - D02 grigio Portland/Portland grey
 - D03 nero/black
- HPL+ metallo/metal/m tal/Metall/metal
- C31 ottone/brass
 - C32 ottone scuro/dark brass
 - C35 inox/inox
 - C36 inox scuro/dark inox

- HPL+ legno/wood/bois/Holz/madera
- Y36 rovere/oak
 - Y34 noce/walnut
 - Y37 rovere affumicato/smoked oak
 - Y39 frassino nero/black ash
 - Y40 frassino argilla/clay ash
- HPL+ ecotouch
- N01 sabbia/sand
 - N02 basalto/basalt

TAVOLI AFFIANCATI RETTANGOLARI / RECTANGULAR SIDE TABLES / TABLES ASSOCI ES RECTANGULAIRES
NEBENEINANDER GESTELLTE RECHTECKIGE TISCHE / MESAS RECTANGULARES PARA COLOCAR UNAS AL LADO DE LAS OTRAS

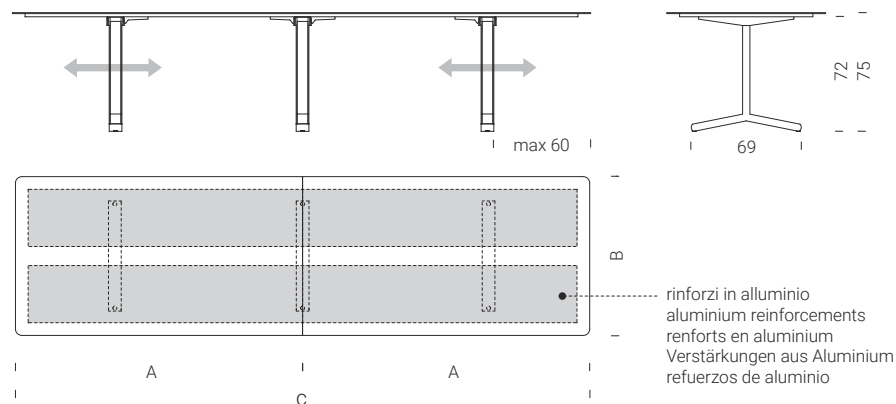

	C x B		S05 S06	S07 S08	L03 L06	L08 L10 L11	D01 D02 D03	C31 C32 C35 C36	Y36 Y34 Y37 Y39 Y40	N01 N02	
UTAV0051	400 x 100	14	5681	5681	4897	5240	5730	7591	5632	5142	+499
UTAV0053	440 x 100	16	6000	6000	5172	5534	6052	8017	5948	5431	+499
UTAV0055	480 x 100	18	6369	6369	5491	5875	6424	8510	6314	5765	+499
UTAV0057	520 x 100	18	6738	6738	5809	6215	6796	9003	6680	6099	+599
UTAV0059	560 x 100	20	7107	7107	6127	6556	7168	9497	7046	6433	+599
UTAV0052	400 x 120	14	6040	-	5207	5571	6092	8070	5988	5467	+499
UTAV0054	440 x 120	16	6424	-	5538	5925	6479	8584	6368	5815	+499
UTAV0056	480 x 120	18	6509	-	5625	6012	6564	8664	6454	5901	+499
UTAV0058	520 x 120	18	6778	-	5843	6252	6836	9057	6720	6135	+599
UTAV0060	560 x 120	20	7147	-	6161	6593	7209	9550	7085	6469	+599

TAVOLI AFFIANCATI A BOTTE / BARREL VAULT SIDE TABLES / TABLES TONNEAU ASSOCI ES
NEBENEINANDER GESTELLTE WEINFASS-TISCHE / MESAS DE BARRIL PARA COLOCAR UNAS AL LADO DE LAS OTRAS

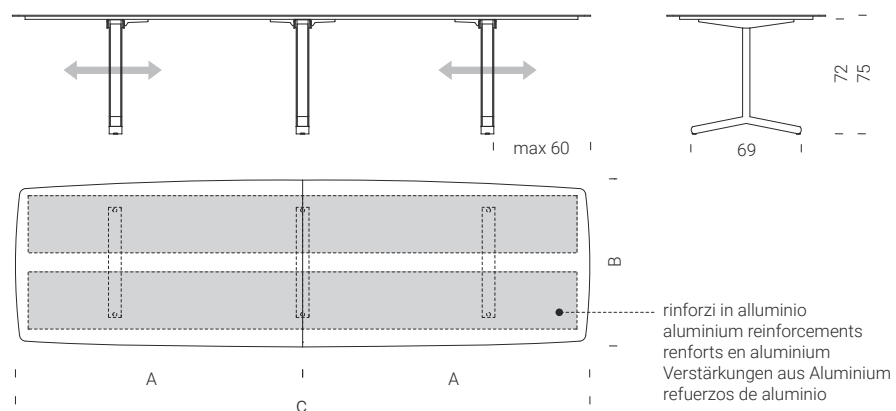

	C x B		S05 S06	S07 S08	L03 L06	L08 L10 L11	D01 D02 D03	C31 C32 C35 C36	Y36 Y34 Y37 Y39 Y40	N01 N02	
UTAV0061	400 x 105	14	5681	5681	4897	5240	5730	7591	5632	5142	+499
UTAV0063	440 x 105	16	6000	6000	5172	5534	6052	8017	5948	5431	+499
UTAV0065	480 x 105	18	6369	6369	5491	5875	6424	8510	6314	5765	+499
UTAV0067	520 x 105	18	6738	6738	5809	6215	6796	9003	6680	6099	+599
UTAV0069	560 x 105	20	7107	7107	6127	6556	7168	9497	7046	6433	+599
UTAV0062	400 x 125	14	6070	-	5233	5599	-	-	6017	5494	+499
UTAV0064	440 x 125	16	6299	-	5430	5810	-	-	6245	5702	+499
UTAV0066	480 x 125	18	6439	-	5551	5939	-	-	6383	5828	+499
UTAV0068	520 x 125	18	6808	-	5869	6280	-	-	6749	6162	+599
UTAV0070	560 x 125	20	7177	-	6187	6620	-	-	7115	6496	+599

maggiorazione per esterno riparato solo per surcharge for sheltered outdoor only for majoration pour ext rieur prot g e juste pour Zuschlag f r drau en gesch tzt nur f r aumento para exterior reparado solo para

- S05 D01 L03 L08 C35
S06 D02 L06 L10 C36
S07 D03 L11
S08

accessori disponibili a pg.148
accessories available on pg.148
accessoires disponibles pg.148
erh ltliches Zubeh r auf pg.148
accesorios disponibles en pg.148

disponibili riduzioni a misura
tailor-made reduction available
disponibles r ductions sur mesure
Verkleinerung nach Kundenwunsch
disponibles reducciones a medida

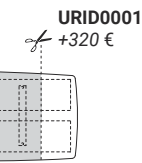
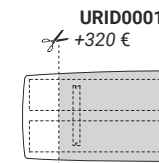
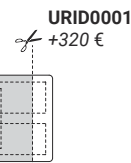
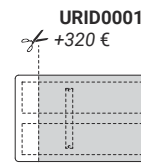

acciaio verniciato/painted steel/acier peint
lackierter Stahl/acero pintado

- C12** bianco/white
- C21** seta/silk
- C23** corda/ecru
- C30** ghisa/cast-iron
- C14** antracite/anthracite
- C08** nero/black
- C18** verde/green
- C26** corten/corten
- C29** bronzo/bronze
- C37** rame/copper
- C38** titanio/titanium

legno massiccio/solid wood
bois massif/Massivholz
madera maciza

- T01** rovere/oak
- T02** noce/walnut
- T03** iroko
- T04** iroko outdoor
- T05** rovere nero/black oak

ceramica/ceramic/c ramique
Keramik/cer mico

- S05** antracite/anthracite
- S06** nero/black
- S07** porfido/porfido
- S08** cardoso/cardoso

HPL POLARIS®

- L03** bianco/white
- L10** grigio chiaro/light grey
- L11** grigio scuro/dark grey

HPL FENIX®

- L08** grigio Londra/London grey
- L06** nero/black

HPL+ cemento/concrete/ciment
zement/cemento



- D01** bianco calce/lime white
- D02** grigio Portland/Portland grey
- D03** nero/black

HPL+ metallo/metal/m tal/Metall/metal

- C31** ottone/brass
- C32** ottone scuro/dark brass
- C35** inox/inox
- C36** inox scuro/dark inox

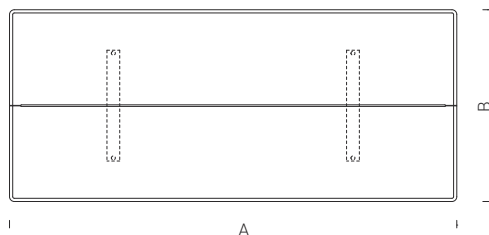
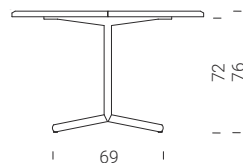
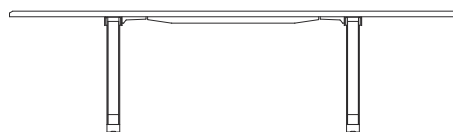
TAVOLI IN MASSELLO / SOLID WOOD TABLES / TABLES EN BOIS MASSIF TISCHE AUS MASSIVHOLZ / MESAS DE MADERA MACIZA



	A x B		T01 T03 T04	T02 T05	
UTAV0020	180 x 90	8	3972	4260	+315
UTAV0021	200 x 90	8	4152	4474	+315
UTAV0023	220 x 90	8	4333	4682	+315
UTAV0026	240 x 90	10	4464	4848	+315
UTAV0029	260 x 90	10	4601	5015	+385
UTAV0032	280 x 90	12	4756	5199	+385
UTAV0035	300 x 90	12	4961	5438	+385
UTAV0022	200 x 100	8	4294	4644	+315
UTAV0024	220 x 100	8	4503	4893	+315
UTAV0027	240 x 100	10	4644	5067	+315
UTAV0030	260 x 100	10	4781	5238	+385
UTAV0033	280 x 100	12	4942	5438	+385
UTAV0036	300 x 100	12	5204	5734	+385
UTAV0025	220 x 120	8	4747	5214	+315
UTAV0028	240 x 120	10	4921	5423	+315
UTAV0031	260 x 120	10	5097	5648	+385
UTAV0034	280 x 120	12	5272	5867	+385
UTAV0037	300 x 120	12	5447	6083	+385
UTAV0038	360 x 120	12	6120	6884	+385

VASSOI / TRAYS / PLATEAUX / TABLETS / BANDEJAS

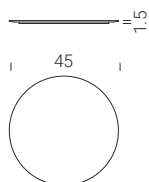

		S05 S06 S07 S08	L03 L06	L08 L10 L11	D01 D02 D03	C31 C32 C35 C36
SACC0007	45 x 1.5	190	165	180	205	245

vedi catalogo a pg.172 / refer to catalogue pg.172
Voir catalogue pg. 172 / siehe Katalog auf pg.172
v ase pg.172 del cat logo

 maggiorazione per esterno riparato **T04**
surcharge for sheltered outdoor **T04**
majoration pour ext rieur prot g  **T04**
Zuschlag f r drau en gesch tzt **T04**
aumento para exterior reparado **T04**

 accessori disponibili a pg.148
accessories available on pg.148
accessoires disponibles pg.148
erh ltliches Zubeh r auf pg.148
accesorios disponibles en pg.148

 disponibili riduzioni a misura
tailor-made reduction available
disponibles r ductions sur mesure
Verkleinerung nach Kundenwunsch
disponibles reducciones a medida

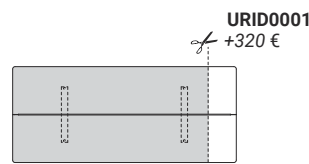

CASSETTO / DRAWER / TIROIR / SCHUBLADE / CAJÓN

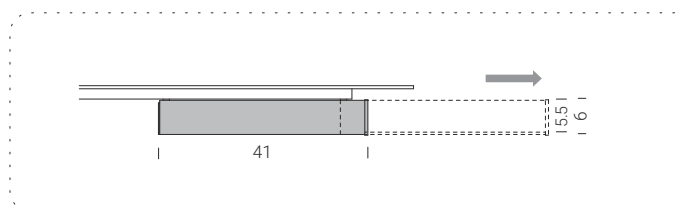
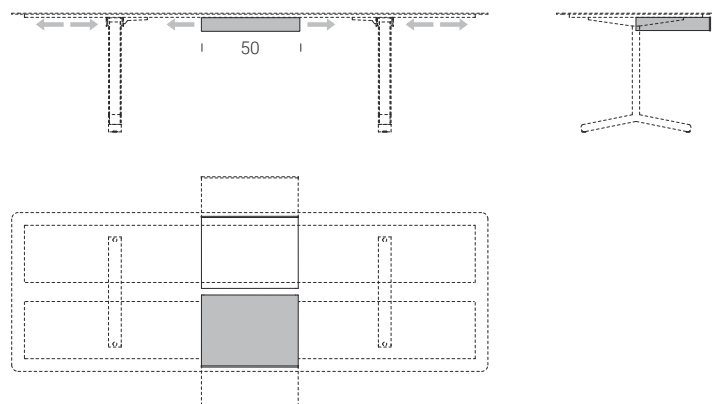

scocca in acciaio e frontale nelle finiture del tavolo.
Steel body and front in the table finishings.
coque en acier et façade dans les mêmes finitions que la table.
Stahlaufbau und Vorderseite in den Tischausführungen.
chapa de acero y frontal en los acabados de la mesa.

- ⚠ cassetto spostabile liberamente in diverse posizioni solo per i tavoli in HPL.
the drawer can be shifted in various positions in HPL tables only.
 tiroir librement déplaçable en diverses positions uniquement pour les tables en HPL.
 Frei verstellbare Schublade in verschiedenen Positionen nur für Tische aus HPL.
 cajón extraíble libremente en diferentes posiciones sólo para las mesas de HPL.

	A x B x C	
SACC0006	50 x 41 x 6	368

vedi catalogo a pg.206
refer to catalogue pg.206
Voir catalogue pg.206
siehe Katalog auf pg.206
véase pg.206 del catálogo

PASSACAPO / CABLE GLAND / PASSE-CÂBLE / KABELDURCHLASS / PASACABLES

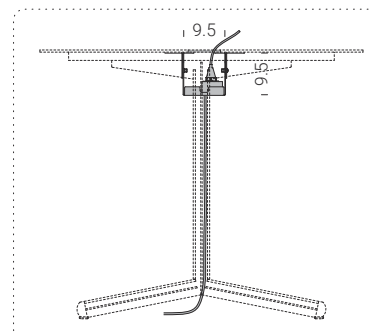
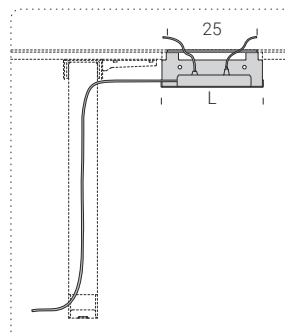
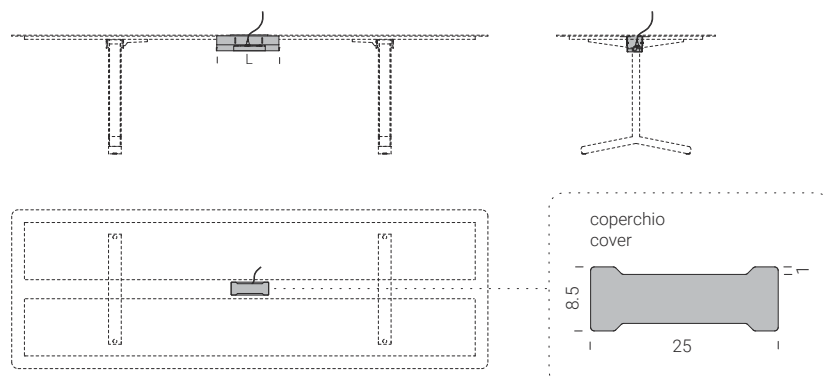

cesto in acciaio e copertura magnetica nelle finiture del tavolo.
steel basket and magnetic cover in the table finishings.
panier en acier et couvercle magnétique dans les mêmes finitions que la table.
Stahlkorb und Magnetabdeckung in der Tischausführung.
cesto de acero y cubierta magnética en los acabados de la mesa.

Il passacavo può essere posizionato esclusivamente nelle aree evidenziate.
the cable tidy can be placed only in the highlighted areas
le passe-câbles peut être placé que dans le domaines mis en évidence
das Kabeldurchführung kann nur in den hervorgehobenen Bereichen angeordnet werden
el pasacables se puede colocar sólo en las áreas resaltadas

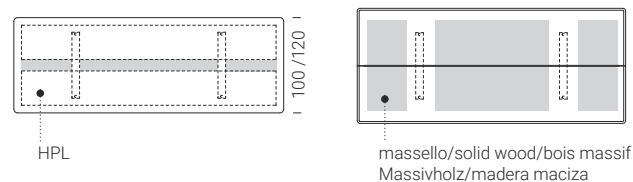

- ⚠ Il passacavo non può essere inserito nei tavoli in HPL profondità 90.
The cable duct cannot be inserted in HPL tables with a depth of 90.
Le passe-câbles ne peut pas être inséré dans les tables en HPL profondeur 90.
Die Kabeldurchführung kann nicht in Tischen aus HPL Tiefe 90 eingesetzt werden.
el pasacable no puede insertarse en las mesas de HPL profundidad 90.

	L	
SACC0003	28	185
SACC0004	40	205

vedi catalogo a pg.156
refer to catalogue pg.156
Voir catalogue pg. 156
siehe Katalog auf pg.156
véase pg.156 del catálogo

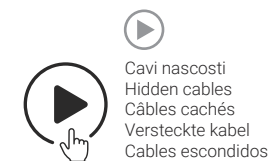

HAMMER

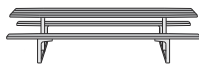

PROGETTATO SENZA COMPROMESSI PER UN IMPIEGO OUTDOOR, È COMUNQUE DISPONIBILE NELLE FINITURE NOCE E ROVERE MASSICCIO PER L'INSERIMENTO INDOOR. PER LA VERSIONE OUTDOOR IL TOP E LE SEDUTE SONO IN IROKO TRATTATO CON OLIO NATURALE, IL TELAIO È IN ACCIAIO CORTEN, O ACCIAIO VERNICIATO A POLVERI, GLI ELEMENTI DI CONNESSIONE SONO IN ACCIAIO INOX E OTTONE.

Designed without compromise for outdoor use, it is available in solid walnut and oak finishes for indoor use. For the outdoor version, the top and the chairs are in Iroko treated with natural oil, the frame is in Corten steel or powder painted steel. The joinery elements are in stainless steel or brass.

Conçu sans compromis pour une utilisation en extérieur, il est toutefois disponible dans les finitions noyer et chêne rouvre massif pour l'insertion d'intérieur. Pour la version d'extérieur, le plateau et les assises sont en Iroko traité avec de l'huile naturelle, la structure est en acier Corten, ou en acier verni par poudres, les éléments de connexion sont en acier inox et laiton.

Kompromissloser Entwurf für den Outdoor-Einsatz, steht jedoch auch als Indoor-Lösung mit Endbehandlung Nussbaum und Massiveiche zur Verfügung. Für die Outdoor-Version sind Abschlussbord und Sitze aus mit natürlichem Öl behandeltem Iroko, der Rahmen ist aus Corten-Stahl oder pulverlackiertem Stahl und die Verbindungsstücke sind aus Edelstahl und Messing.

Diseñada para usarla sin problemas en el exterior, también está disponible en los acabados nogal y roble macizo para su uso en el interior. Para la versión de exterior el sobre y los asientos son de iroko tratado con aceite natural, el bastidor es de acero corten, o acero tratado con barniz en polvo, los elementos de unión son de acero inoxidable y latón.



Disponibili riduzioni a misura
Custom reductions available
Réductions sur mesure disponibles
Verkürzungen auf Maß erhältlich
Disponibles reducciones a medida



Uso in esterno
Outdoor use
Utilisation en extérieur
Verwendung im Außenbereich
Uso en exteriores



Piedini regolabili in acciaio
Adjustable feet in steel
Pieds réglables en acier
Regulierbaren Stahlfüßchen
Patas regulables de acero

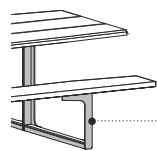

acciaio verniciato/painted steel/acier peint
lackierter Stahl/acero pintado

C12 bianco/white
C21 seta/silk
C23 corda/ecru
C30 ghisa/cast-iron
C14 antracite/anthracite
C08 nero/black

C18 verde/green
C26 corten/corten
C29 bronzo/bronze
C27 corten outdoor
C37 rame/copper
C38 titanio/titanium



legno massiccio/solid wood/bois massif
Massivholz/madera maciza

T01 rovere/oak **T04** iroko outdoor
T02 noce/walnut **T05** rovere nero/black oak
T03 iroko

TAVOLI CON PANCA / TABLES WITH BENCH / TABLES AVEC BANC / TISCHE MIT BÄNKEN / MESITAS CON UN BANQUILLO

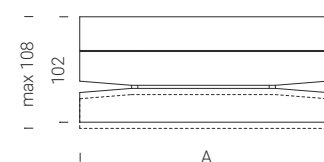
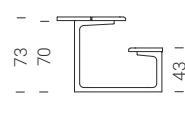
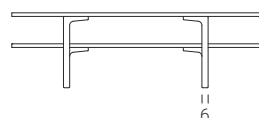
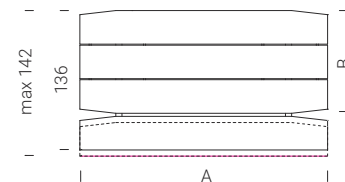
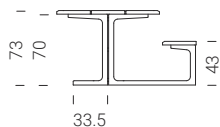
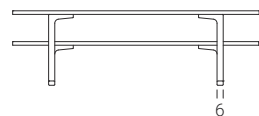
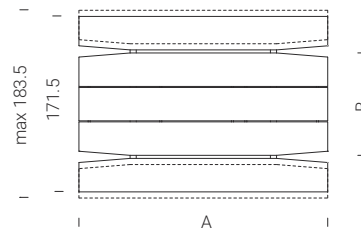
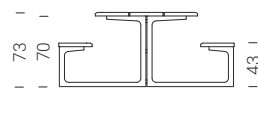
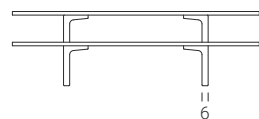

TAVOLI / TABLES / TABLES / TISCHEN / MESAS

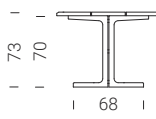
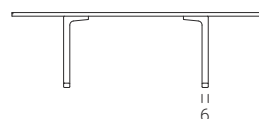

	A x B		T01 T03	T02 T05	 T04
BTAV0001	180 x 100	8	5993	6607	6284
BTAV0002	240 x 100	10	6731	7532	6925
BTAV0009	300 x 100	12	7857	8848	8286

	A x B		T01 T03	T02 T05	 T04
BTAV0003	180 x 100	8	4831	5318	5125
BTAV0004	240 x 100	10	5419	6057	5636
BTAV0010	300 x 100	12	6069	6784	6312

	A x B		T01 T03	T02 T05	 T04
BTAV0005	180 x 66	8	3336	3699	3458
BTAV0006	240 x 66	10	3776	4252	3840
BTAV0011	300 x 66	12	4229	4763	4301

	A x B		T01 T03	T02 T05	 T04
BTAV0007	180 x 100	8	3646	4008	3943
BTAV0008	240 x 100	10	4098	4572	4337
BTAV0012	300 x 100	12	4736	5324	5082



esterno **T04**
outdoor **T04**
extérieur **T04**
draußen **T04**
exterior **T04**



disponibili riduzioni a misura
custom reductions available
réductions sur mesure disponibles
Verkürzungen auf Maß erhältlich
disponibles reducciones a medida

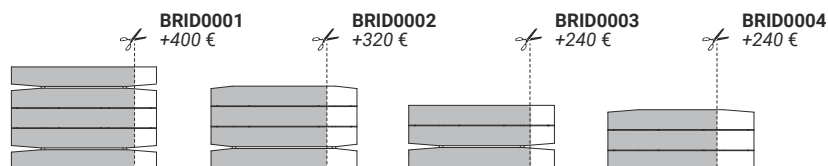

HAMMER

T7



GRAZIE ALLA TECNOLOGIA DI PIEGATURA TRIDIMENSIONALE DEI PROFILI È STATO POSSIBILE REALIZZARE UN SISTEMA TAVOLI CHE OFFRE MOLTEPLICI GRADI DI LIBERTÀ. IL TELAIO LEGGERO MA RESISTENTE SUPPORTA TAVOLI DA 160 A 300CM DI LUNGHEZZA, INOLTRE ACCOGLIE 5 TIPOLOGIE DI GEOMETRIE TOP E RENDE POSSIBILE ANCHE LA RIDUZIONE A MISURA

Thanks to the 3D profile bending technology, it has been possible to create a table system that provides multiple degrees of freedom. The light yet resistant frame supports tables between 160 and 300cm long; moreover, it can accommodate 5 types table top profiles and makes custom reduction possible.

Grâce à la technologie de pliage tridimensionnel des profils, il a été possible de réaliser un système de tables qui offre de nombreux niveaux de liberté. Le châssis léger, mais résistant, supporte des tables de 160 à 300 cm de longueur, en outre il accueille 5 typologies de géométries de plateaux et permet aussi la réduction sur mesure.

Dank eines technologisch ausgefeilten, dreidimensionalen Biegeverfahrens erhält man Profile für ein Tischsystem mit einem breiten Spektrum an freien Gestaltungsmöglichkeiten. Leichte, formstabile Gestelle tragen Tischplatten von 160 bis 300 cm Länge, in fünf verschiedenen Ausformungen und Größen, wobei auch die Verkürzung nach Maß vorgesehen ist.

Gracias a la tecnología de doblado tridimensional de los perfiles, se ha podido realizar un sistema de mesas que ofrece múltiples niveles de libertad. El bastidor ligero pero resistente, soporta mesas de 160 a 300cm de largo: además, cuenta con 5 tipos de geometrías para la encimera y también permite la reducción a medida.



Disponibili riduzioni a misura
Custom reductions available
Réductions sur mesure disponibles
Verkürzungen auf Maß erhältlich
Disponibles reducciones a medida



Passacavo disponibile per tutti i top
Cable gland available for all tops
Passe-câble disponible pour tous les plateaux
Kabeldurchlass für alle Abschlussborde verfügbar
Pasacables disponible para todos los sobres



Piede in ottone, ottone brunito o verniciatura a polveri
Foot in brass, dark brass or powder coated
Pied en laiton, laiton bruni ou thermolaqué
Fuß aus Messing, Messing brüniert oder pulverbeschichtet
Pie en latón, latón bruñido o con recubrimiento de polvo



EXTENDABLE
TABLE SYSTEM
registered community
design

- acciaio verniciato/painted steel/acier peint
lackierter Stahl/acero pintado
- C12** bianco/white
 - C21** seta/silk
 - C23** corda/ecru
 - C30** ghisa/cast-iron
 - C14** antracite/anthracite
 - C08** nero/black
 - C18** verde/green
 - C26** corten/corten
 - C29** bronzo/bronze
 - C37** rame/copper
 - C38** titanio/titanium

- legno massiccio/solid wood
bois massif/Massivholz
madera maciza
- T01** rovere/oak
 - T02** noce/walnut
 - T03** iroko
 - T04** iroko outdoor
 - T05** rovere nero/black oak

- ceramica/ceramic/c eramique
Keramik/cer amico
- S05** antracite/anthracite
 - S06** nero/black
 - S07** porfido/porfido
 - S08** cardoso/cardoso

- HPL POLARIS®
- L03** bianco/white
 - L10** grigio chiaro/light grey
 - L11** grigio scuro/dark grey
- HPL FENIX®
- L08** grigio Londra/London grey
 - L06** nero/black

- HPL+ legno/wood/bois/Holz/madera
- Y36** rovere/oak
 - Y34** noce/walnut
 - Y37** rovere affumicato/smoked oak
 - Y39** frassino nero/black ash
 - Y40** frassino argilla/clay ash

TAVOLI ALLUNGABILI / EXTENDABLE TABLES / TABLES EXTENSIBLES AUSZIEHBARE TISCHE / MESAS EXTENSIBLES

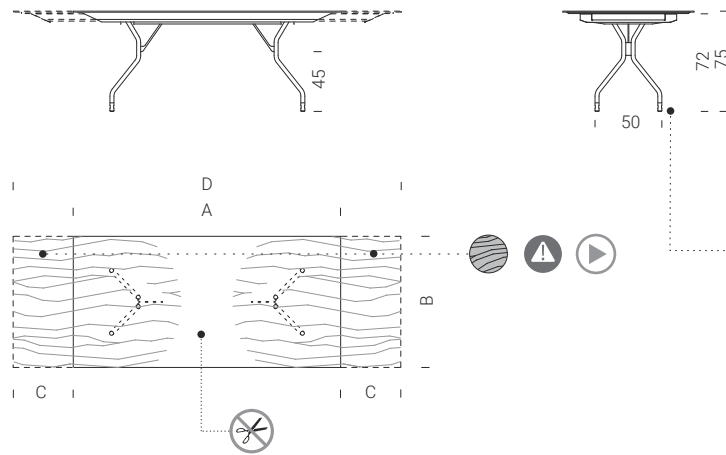

	A / D x B	C		S05 S06 S07 S08	L03 L06	L08 L10 L11	Y36 Y34 Y37 Y39 Y40
7TAV0042	170 / 260 x 90	45+45	6 (10)	3990	3532	3779	4009
7TAV0045	170 / 260 x 98	45+45	6 (10)	4073	3605	3858	4092
7TAV0043	200 / 290 x 90	45+45	8 (12)	4224	3739	4001	4244
7TAV0046	200 / 290 x 98	45+45	8 (12)	4330	3833	4101	4351
7TAV0044	230 / 320 x 90	45+45	10 (12)	4562	4038	4321	4584
7TAV0047	230 / 320 x 98	45+45	10 (12)	4674	4137	4427	4697

feet disponibili in ottone **C31**, ottone scuro **C32** o verniciato a polveri nella finitura del telaio del tavolo.
feet available in **C31** brass, **C32** dark brass or painted steel in the finish of the table frame.

le allunghe possono essere posizionate all'interno del tavolo.
the extensions can be positioned inside the table.
les rallonges peuvent  tre plac es   l'int rieur de la table.
die Verl ngerungen k nnen innerhalb des Tisches gelegt werden.
las extensiones pueden colocarse dentro de la mesa.

TAVOLI DOGATI / SLATTED TABLES / TABLES   LATTES DAUBEN-TISCHE / MESAS LAMINADAS

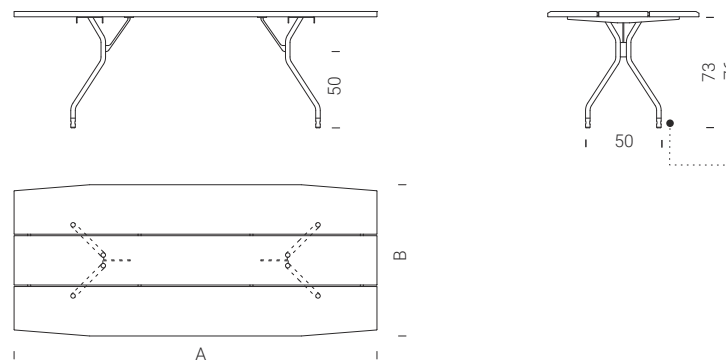

	A x B		T01 T03	T02 T05	
7TAV0048	180 x 100	6	3336	3665	3503
7TAV0051	240 x 100	10	3955	4711	4215
7TAV0052	300 x 100	12	4968	5487	5227

feet disponibili in ottone **C31**, ottone scuro **C32** o verniciato a polveri nella finitura del telaio del tavolo.
feet available in **C31** brass, **C32** dark brass or painted steel in the finish of the table frame.

impiallacciatura continua su top e allunghe
continues veneer on top and extensions
les veines du placage bois suivent sur les rallonges
sauberer Furnierverlauf  ber Tisch- und Verl ngerungsplatte
chapa de madera contin a en el plano y extensiones

top e allunghe nella stessa finitura
top and extensions with the same finish
plateau et rallonges dans la m me finition
Abdeck- und Ausziehplatten in derselben Vollendung
Encimera y extensiones en el mismo acabado

Apertura allunghe
Opening of extensions
Ouverture de rallonges
 ffnung verl ngerungsst cke
Apertura de la extensi n

esterno **T04**
outdoor **T04**
ext rieur **T04**
drau en **T04**
exterior **T04**

disponibili riduzioni a misura
tailor-made reduction available
disponibles r ductions sur mesure
Verkleinerung nach Kundenwunsch
disponibles reducciones a medida

7RID0001
+240  

acciaio verniciato/painted steel/acier peint
lackierter Stahl/acero pintado

- C12** bianco/white
- C21** seta/silk
- C23** corda/ecru
- C30** ghisa/cast-iron
- C14** antracite/anthracite
- C08** nero/black
- C18** verde/green
- C26** corten/corten
- C29** bronzo/bronze
- C37** rame/copper
- C38** titanio/titanium



- legno massiccio/solid wood
bois massif/Massivholz
madera maciza
- T01** rovere/oak
 - T02** noce/walnut
 - T03** iroko
 - T04** iroko outdoor
 - T05** rovere nero/black oak

- ceramica/ceramic/c eramique
Keramik/cer mico
- S05** antracite/anthracite
 - S06** nero/black
 - S07** porfido/porfido
 - S08** cardoso/cardoso

- HPL POLARIS®
- L03** bianco/white
 - L10** grigio chiaro/light grey
 - L11** grigio scuro/dark grey
- HPL FENIX®
- L08** grigio Londra/London grey
 - L06** nero/black

- HPL+ cemento/concrete/ciment
zement/cemento
- D01** bianco calce/lime white
 - D02** grigio Portland/Portland grey
 - D03** nero/black
- HPL+ metallo/metal/m tal/Metall/metal
- C31** ottone/brass
 - C32** ottone scuro/dark brass
 - C35** inox/inox
 - C36** inox scuro/dark inox

- HPL+ legno/wood/bois/Holz/madera
- Y36** rovere/oak
 - Y34** noce/walnut
 - Y37** rovere affumicato/smoked oak
 - Y39** frassino nero/black ash
 - Y40** frassino argilla/clay ash
- HPL+ ecotouch
- N01** sabbia/sand
 - N02** basalto/basalt

**TAVOLI RETTANGOLARI / RECTANGULAR TABLES / TABLES RECTANGULAIRES
RECHTECKIGE TISCHE / MESAS RECTANGULARES**

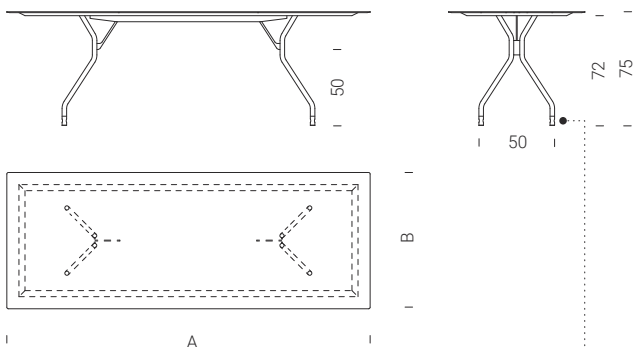

	A x B		T01 T03 T04	T02 T05	S05 S06	S07 S08	L03 L06	L08 L10 L11	D01 D02 D03	C31 C32 C35 C36	Y36 Y34 Y37 Y39 Y40	N01 N02		
7TAV0001	160 x 90	6	2070	2149	1934	1934	1682	1786	1955	2608	1936	1772	1116	+167
7TAV0002	180 x 90	8	2216	2314	2112	2112	1871	1985	2135	2868	2127	1929	1243	+167
7TAV0004	200 x 90	8	2374	2508	2232	2232	1930	2065	2254	3060	2235	2028	1281	+260
7TAV0006	220 x 90	8	2556	2703	2351	2351	2058	2205	2404	3555	2384	2152	1319	+260
7TAV0008	240 x 90	10	2744	3135	2617	2617	2266	2425	2644	3891	2622	2370	1453	+260
7TAV0003	180 x 98	8	2321	2444	2162	2162	1880	2003	2184	2981	2166	1960	1247	+167
7TAV0005	200 x 98	8	2389	2659	2341	2341	2026	2171	2367	3241	2347	2120	1299	+260
7TAV0007	220 x 98	8	2563	2861	2486	2486	2169	2327	2534	3783	2515	2260	1391	+260
7TAV0009	240 x 98	10	2752	3141	2754	2754	2388	2559	2786	4139	2765	2488	1531	+260
7TAV0010	300 x 98	12	3456	3658	3222	3222	2822	3026	3290	4973	3267	2919	1809	+260

pedi disponibili in ottone **C31**, ottone scuro **C32** o verniciato a polveri nella finitura del telaio del tavolo.
feet available in **C31** brass, **C32** dark brass or painted steel in the finish of the table frame.

**TAVOLI A TESTA TONDA / ROUND HEAD TABLES / TABLES AUX EXTR MIT S ARRONDIES
RUNDER KOPF TISCHE / MESAS REDONDAS DE ESTRUCTURA LINEAL**

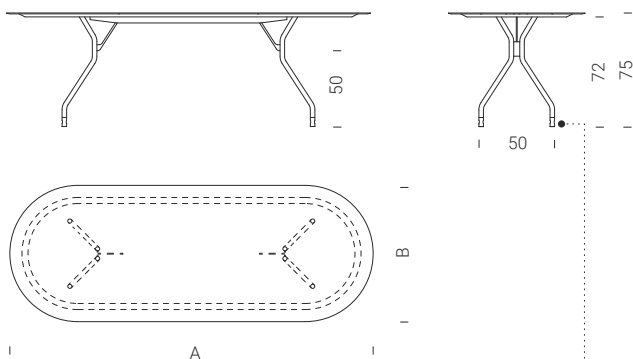

	A x B		T01 T03 T04	T02 T05	S05 S06	S07 S08	L03 L06	L08 L10 L11	D01 D02 D03	C31 C32 C35 C36	Y36 Y34 Y37 Y39 Y40	N01 N02		
7TAV0011	180 x 90	8	2216	2314	2112	2112	1871	1985	2135	2868	2127	1929	1243	+167
7TAV0013	200 x 90	8	2374	2508	2232	2232	1930	2065	2254	3060	2235	2028	1281	+260
7TAV0015	220 x 90	8	2556	2703	2351	2351	2058	2205	2404	3555	2384	2152	1319	+260
7TAV0017	240 x 90	10	2744	3135	2617	2617	2266	2425	2644	3891	2622	2370	1453	+260
7TAV0012	180 x 98	8	2321	2444	2162	2162	1880	2003	2184	2981	2166	1960	1247	+167
7TAV0014	200 x 98	8	2389	2659	2341	2341	2026	2171	2367	3241	2347	2120	1299	+260
7TAV0016	220 x 98	8	2563	2861	2486	2486	2169	2327	2534	3783	2515	2260	1391	+260
7TAV0018	240 x 98	10	2752	3141	2754	2754	2388	2559	2786	4139	2765	2488	1531	+260
7TAV0019	300 x 98	12	3456	3658	3222	3222	2822	3026	3290	4973	3267	2919	1809	+260

pedi disponibili in ottone **C31**, ottone scuro **C32** o verniciato a polveri nella finitura del telaio del tavolo.
feet available in **C31** brass, **C32** dark brass or painted steel in the finish of the table frame.

maggiorazione per esterno riparato solo per surcharge for sheltered outdoor only for majoration pour ext rieur prot g  juste pour Zuschlag f r drau en gesch tzt nur f r aumento para exterior reparado solo para

- T04 S05 D01 L03 L08 C35**
S06 D02 L06 L10 C36
S07 D03 L11
S08

solo telaio (info pg.98)
frame only (info on pg.98)
seulement b ti (info pg.98)
Ausschlie lich Rahmen (Info pg.98)
solo marco (informaci n pg.98)

accessori disponibili a pg.156
accessories available on pg.156
accessoires disponibles pg.156
erh ltliches Zubeh r auf pg.156
accesorios disponibles en pg.156

disponibili riduzioni a misura
tailor-made reduction available
disponibles r ductions sur mesure
Verkleinerung nach Kundenwunsch
disponibles reducciones a medida

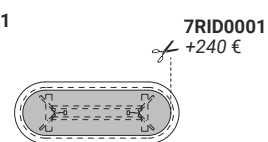
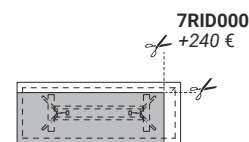

acciaio verniciato/painted steel/acier peint
lackierter Stahl/acero pintado

- C12** bianco/white
- C21** seta/silk
- C23** corda/ecru
- C30** ghisa/cast-iron
- C14** antracite/anthracite
- C08** nero/black
- C18** verde/green
- C26** corten/corten
- C29** bronzo/bronze
- C37** rame/copper
- C38** titanio/titanium

legno massiccio/solid wood
bois massif/Massivholz
madera maciza

- T01** rovere/oak
- T02** noce/walnut
- T03** iroko
- T04** iroko outdoor
- T05** rovere nero/black oak

ceramica/ceramic/c eramique
Keramik/cer amico

- S05** antracite/anthracite
- S06** nero/black
- S07** porfido/porfido
- S08** cardoso/cardoso

HPL POLARIS®

- L03** bianco/white
- L10** grigio chiaro/light grey
- L11** grigio scuro/dark grey

HPL FENIX®

- L08** grigio Londra/London grey
- L06** nero/black

HPL+ cemento/concrete/ciment
zement/cemento

- D01** bianco calce/lime white
- D02** grigio Portland/Portland grey
- D03** nero/black

HPL+ metallo/metal/m etal/Metall/metal

- C31** ottone/brass
- C32** ottone scuro/dark brass
- C35** inox/inox
- C36** inox scuro/dark inox

HPL+ legno/wood/bois/Holz/madera

- Y36** rovere/oak
- Y34** noce/walnut
- Y37** rovere affumicato/smoked oak
- Y39** frassino nero/black ash
- Y40** frassino argilla/clay ash

HPL+ ecotouch

- N01** sabbia/sand
- N02** basalto/basalt

TAVOLI A BOTTE / BARREL VAULT TABLES / TABLES TONNEAU WEINFASS-TISCHE / MESAS DE BARRIL

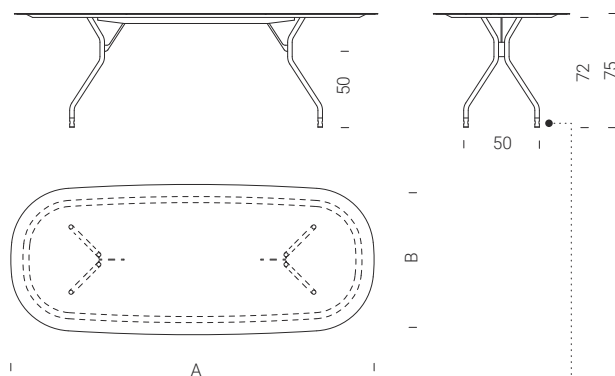

	A x B		T01 T03 T04	T02 T05	S05 S06	S07 S08	L03 L06	L08 L10 L11	D01 D02 D03	C31 C32 C35 C36	Y36 Y34 Y37 Y39 Y40	N01 N02		
7TAV0020	180 x 98	8	2321	2444	2162	2162	1880	2003	2184	2981	2166	1960	1247	+167
7TAV0022	200 x 98	8	2389	2659	2341	2341	2026	2171	2367	3241	2347	2120	1299	+260
7TAV0024	220 x 98	8	2563	2861	2486	2486	2169	2327	2534	3783	2515	2260	1391	+260
7TAV0026	240 x 98	10	2752	3141	2754	2754	2388	2559	2786	4139	2765	2488	1531	+260
7TAV0028	300 x 98	12	3456	3658	3222	3222	2822	3026	3290	4973	3267	2919	1809	+260
7TAV0021	180 x 105	8	2506	2639	2334	2334	2030	2163	2358	3219	2339	2116	1346	+167
7TAV0023	200 x 105	8	2628	2925	2575	2575	2288	2388	2603	3565	2582	2332	1429	+260
7TAV0025	220 x 105	8	2819	3147	2735	2735	2386	2560	2787	4161	2766	2486	1530	+260
7TAV0027	240 x 105	10	2982	3340	3030	3030	2627	2814	3065	4553	3042	2737	1684	+260
7TAV0029	300 x 105	12	3801	4024	3544	3544	3104	3329	3618	5471	3594	3211	1990	+260

pedi disponibili in ottone **C31**, ottone scuro **C32** o verniciato a polveri nella finitura del telaio del tavolo.
feet available in **C31** brass, **C32** dark brass or painted steel in the finish of the table frame.

TAVOLI OVALI / OVAL TABLES / TABLES OVALES OVALTISCHE / MESAS OVALADAS

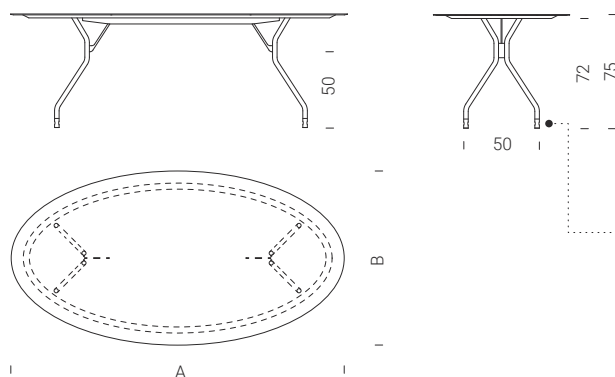

	A x B		T01 T03 T04	T02 T05	S05 S06	S07 S08	L03 L06	L08 L10 L11	D01 D02 D03	C31 C32 C35 C36	Y36 Y34 Y37 Y39 Y40	N01 N02		
7TAV0030	160 x 85	6	1981	2062	1897	1897	1589	1688	1847	2453	1829	1674	1019	+167
7TAV0031	180 x 95	8	2287	2388	2154	2154	1814	1934	2051	2873	2092	1892	1163	+167
7TAV0032	200 x 105	8	2558	2848	2467	2467	2071	2226	2421	3626	2404	2155	1328	+260
7TAV0033	220 x 115	8	2924	3274	2806	2806	2363	2543	2759	4204	2743	2438	1515	+260
7TAV0034	248 x 128	10	3090	3548	3016	-	2851	3071	-	-	3308	2923	1828	+260

pedi disponibili in ottone **C31**, ottone scuro **C32** o verniciato a polveri nella finitura del telaio del tavolo.
feet available in **C31** brass, **C32** dark brass or painted steel in the finish of the table frame.

maggiorazione per esterno riparato solo per surcharge for sheltered outdoor only for majoration pour ext rieur prot g e juste pour Zuschlag f r drau en gesch tzt nur f r aumento para exterior reparado solo para

T04 S05 D01 L03 L08 C35
S06 D02 L06 L10 C36
S07 D03 L11
S08

solo telaio (info pg.98)
frame only (info on pg.98)
seulement b ti (info pg.98)
Ausschlie lich Rahmen (Info pg.98)
solo marco (informaci n pg.98)

accessori disponibili a pg.156
accessories available on pg.156
accessoires disponibles pg.156
erh ltliches Zubeh r auf pg.156
accesorios disponibles en pg.156

disponibili riduzioni a misura
tailor-made reduction available
disponibles r ductions sur mesure
Verkleinerung nach Kundenwunsch
disponibles reducciones a medida

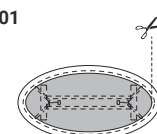
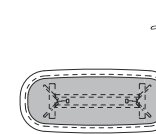

PASSACAVO / CABLE GLAND / PASSE-CÂBLE/KABELDURCHLASS / PASACABLES

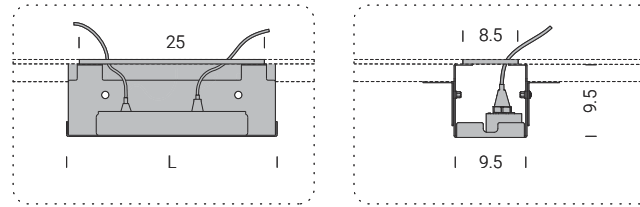
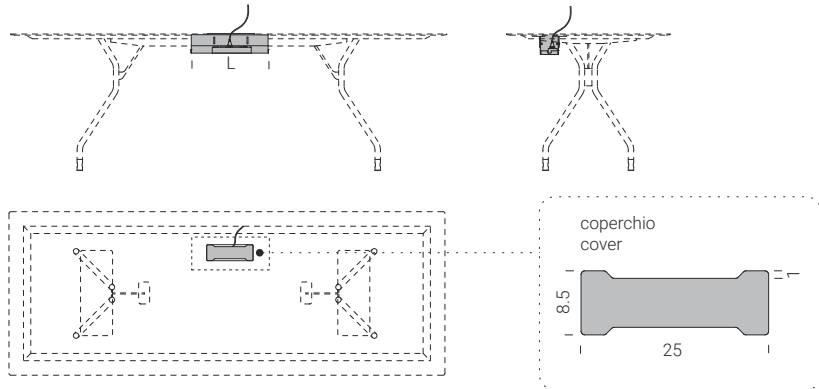

cesto in acciaio e copertura magnetica nelle finiture del tavolo.
 steel basket and magnetic cover in the table finishings.
 panier en acier et couvercle magnétique dans les mêmes finitions que la table.
 Stahlkorb und Magnetabdeckung in der Tischausführung.
 cesto de acero y cubierta magnética en los acabados de la mesa.

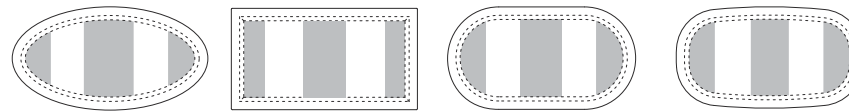

Il passacavo può essere posizionato esclusivamente nelle aree evidenziate.
 the cable tidy can be placed only in the highlighted areas
 le passe-câbles peut être placé que dans les domaines mis en évidence
 das Kabeldurchführung kann nur in den hervorgehobenen Bereichen angeordnet werden
 el pasacables se puede colocar sólo en las áreas resaltadas

**CASSETTO CON PASSACAVO / DRAWER WITH CABLE GLAND / TIROIR AVEC PASSE-CÂBLE
 SCHUBLADE MIT KABELDURCHLASS / CAJÓN CON PASACABLES**

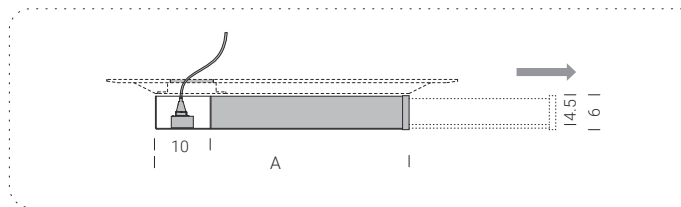
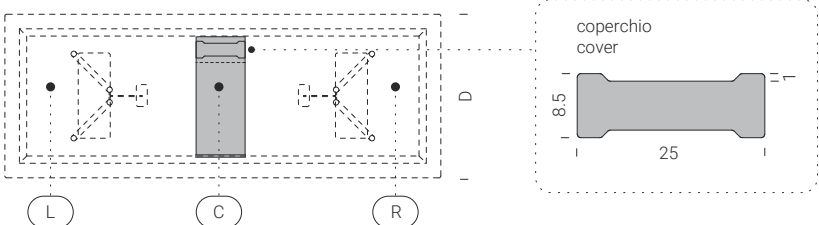
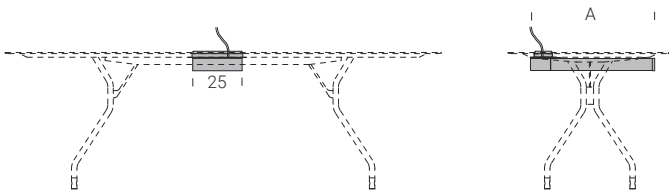

scocca in acciaio e frontale nelle finiture del tavolo. (il prezzo include la foratura del top tavolo).
 Steel body and front in the table finishings. (the price includes perforation of the table top).
 coque en acier et façade dans les mêmes finitions que la table. (le prix inclut le perçage du plateau de la table).
 Stahllaufbau und Vorderseite in den Tischausführungen. (Die Bohrung der Tischplatte ist im Preis inbegriffen).
 chapa de acero y frontal en los acabados de la mesa. (el precio incluye el perforado de la encimera).

ordinabile in posizione L (sinistra), R (destra), C (centrale).
 available in the following positions: L (left), R (right), C (central).
 peut être commandé en position L (gauche), R (droite), C (centrale).
 aufstellbar in Position L (links), R (rechts), C (Mitte).
 disponible en posición L (izquierda), R (derecha), C (central).

	L	
SACC0003	28	185
SACC0004	40	205

vedi catalogo a pg.156
 refer to catalogue pg.156
 Voir catalogue pg. 156
 siehe Katalog auf pg.156
 véase pg.156 del catálogo

	A x B x C (D)	
GACC0003	68 x 25 x 6 (90)	320

vedi catalogo a pg.200 / refer to catalogue pg.200
 Voir catalogue pg. 200 / siehe Katalog auf pg.200
 véase pg.200 del catálogo



ceramica/ceramic/c eramique
Keramik/cer amico

S05 antracite/anthracite
S06 nero/black
S07 porfido/porfido
S08 cardoso/cardoso



HPL POLARIS®

L03 bianco/white
L10 grigio chiaro/light grey
L11 grigio scuro/dark grey

HPL FENIX®

L08 grigio Londra/London grey
L06 nero/black



HPL+ cemento/concrete/ciment
zement/cemento

D01 bianco calce/lime white
D02 grigio Portland/Portland grey
D03 nero/black

HPL+ metallo/metal/m etal/Metall/metal

C31 ottone/brass
C32 ottone scuro/dark brass
C35 inox/inox
C36 inox scuro/dark inox

CASSETTO / DRAWER / TIROIR / SCHUBLADE / CAJ N

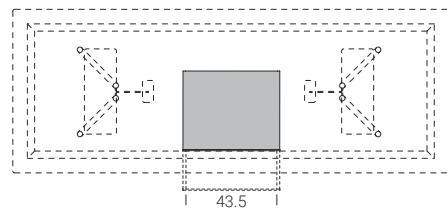
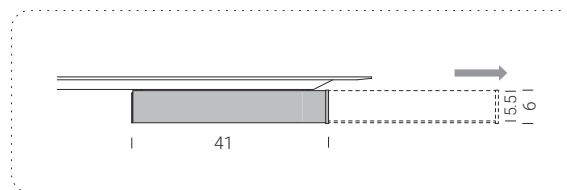
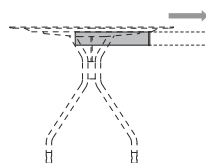
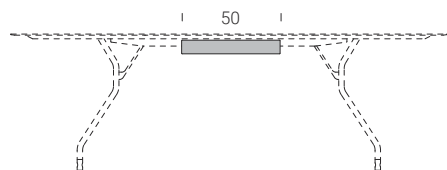

scocca in acciaio e frontale nelle finiture del tavolo.
Steel body and front in the table finishings.
coque en acier et fa ade dans les m mes finitions que la table.
Stahlaufbau und Vorderseite in den Tischausf hrungen.
chapa de acero y frontal en los acabados de la mesa.



disponibile per tavoli a partire da lunghezza 220 cm
available for tables starting from a length of 220 cm
disponible pour les tables   partir de 220 cm de longueur
verf gbar f r Tische ab einer L nge von 220 cm
disponible para mesas desde 220 cm de longitud

A x B x C

SACC0006	50 x 41 x 6	368
-----------------	-------------	-----

vedi catalogo a pg.206
refer to catalogue pg.206
Voir catalogue pg.206
siehe Katalog auf pg.206
v ase pg.206 del cat logo

VASSOI / TRAYS / PLATEAUX / TABLETS / BANDEJAS

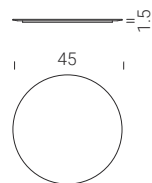

S05 **L08** **D01** **C31**
S06 **L10** **D02** **C32**
S07 **L11** **D03** **C35**
S08 **L06** **C36**

SACC0007	45 x 1.5	190	165	180	205	245
-----------------	----------	-----	-----	-----	-----	-----

vedi catalogo a pg.172 / refer to catalogue pg.172
Voir catalogue pg. 172 / siehe Katalog auf pg.172
v ase pg.172 del cat logo

T8

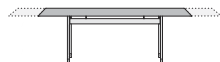

UN PROGETTO DI LE CORBUSIER DEL 1928 HA ISPIRATO IL DESIGN DI QUESTO SISTEMA TAVOLI. I NUOVI MATERIALI HANNO CONSENTITO UN RIDISEGNO ALL'INSEGNA DELLA LEGGEREZZA E DI UNA GRANDE LIBERTÀ DI CONFIGURAZIONE. E' UNA COLLEZIONE DI TAVOLI E PANCHE DISPONIBILI NELLA VERSIONE FISSA E ALLUNGABILE.

A 1928 Le Corbusier project inspired the design of this table system. New materials have enabled a re-designing of this project in pursuit of lightness along with a great freedom of configuration. This is a collection of tables and benches available in both fixed and extendable versions.

Un projet de Le Corbusier de 1928 a inspiré le design de ce système de tables. Les nouveaux matériaux ont permis de le redessiner à l'enseigne de la légèreté et d'une grande liberté de configuration. C'est une collection de tables et de bancs disponibles dans la version fixe et extensible.

Ein Entwurf von Le Corbusier aus dem Jahr 1928 diente als Anregung für das Design dieses Tischsystems. Innovative Materialien prägen das aktualisierte Konzept, bei dem Leichtigkeit und eine große Gestaltungsfreiheit im Vordergrund stehen. Eine Kollektion von Tischen und Bänken, die als feste oder ausziehbare Version zur Verfügung steht.

Un diseño de Le Corbusier de 1928, inspiró el diseño de este sistema de mesas. Los nuevos materiales han permitido realizar un nuevo diseño sobre la base del antiguo, caracterizado por ligereza y gran libertad de configuración. Es una colección de mesas y banquillos disponibles en la versión fija y extensible.



Disponibili riduzioni a misura
Custom reductions available
Réductions sur mesure disponibles
Verkürzungen auf Maß erhältlich
Disponibles reducciones a medida



Passacavo disponibile per tutti i top
Cable gland available for all tops
Passe-câble disponible pour tous les plateaux
Kabeldurchlass für alle Abschlussborde verfügbar
Pasacables disponible para todos los sobres



Piede in ottone, ottone brunito o verniciatura a polveri
Foot in brass, dark brass or powder coated
Pied en laiton, laiton bruni ou thermolaqué
Fuß aus Messing, Messing brüniert oder pulverbeschichtet
Pie en latón, latón bruñido o con recubrimiento de polvo



EXTENDABLE
TABLE SYSTEM
registered community
design

- acciaio verniciato/painted steel/acier peint
lackierter Stahl/acero pintado
- C12** bianco/white
 - C21** seta/silk
 - C23** corda/ecru
 - C30** ghisa/cast-iron
 - C14** antracite/anthracite
 - C08** nero/black
 - C18** verde/green
 - C26** corten/corten
 - C29** bronzo/bronze
 - C37** rame/copper
 - C38** titanio/titanium

- ceramica/ceramic/c eramique
Keramik/cer mico
- S05** antracite/anthracite
 - S06** nero/black
 - S07** porfido/porfido
 - S08** cardoso/cardoso

- HPL POLARIS®
- L03** bianco/white
 - L10** grigio chiaro/light grey
 - L11** grigio scuro/dark grey
- HPL FENIX®
- L08** grigio Londra/London grey
 - L06** nero/black

- HPL+ legno/wood/bois/Holz/madera
- Y36** rovere/oak
 - Y34** noce/walnut
 - Y37** rovere affumicato/smoked oak
 - Y39** frassino nero/black ash
 - Y40** frassino argilla/clay ash

TAVOLI ALLUNGABILI / EXTENDABLE TABLES / TABLES EXTENSIBLES
AUSZIEHBARE TISCHE / MESAS EXTENSIBLES

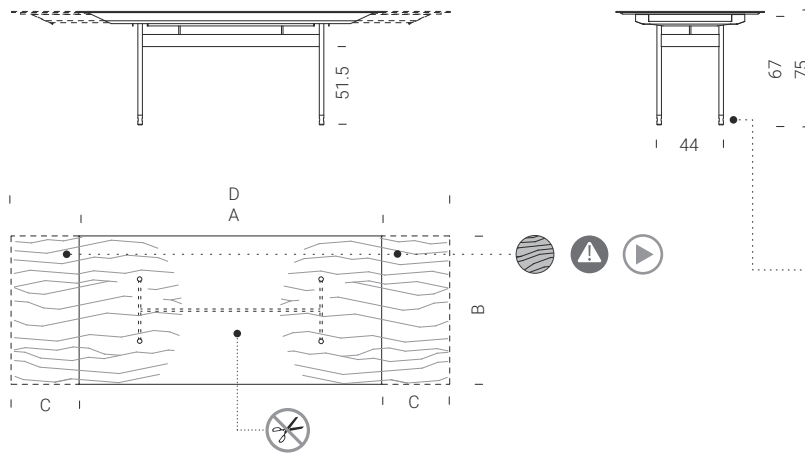

	A / D x B	C		S05	S06	L08	Y36
				S07	L03	L10	Y34
				S08	L06	L11	Y37
							Y39
							Y40
8TAV0055	170 / 260 x 90	45+45	6 (10)	4132	3657	3913	4152
8TAV0058	170 / 260 x 98	45+45	6 (10)	4218	3733	3995	4238
8TAV0056	200 / 290 x 90	45+45	8 (12)	4374	3872	4143	4395
8TAV0059	200 / 290 x 98	45+45	8 (12)	4484	3969	4247	4506
8TAV0057	230 / 320 x 90	45+45	10 (12)	4724	4182	4474	4747
8TAV0060	230 / 320 x 98	45+45	10 (12)	4840	4285	4585	4864

❗ piedi disponibili in ottone **C31**, ottone scuro **C32** o verniciato a polveri nella finitura del telaio del tavolo.
feet available in **C31** brass, **C32** dark brass or painted steel in the finish of the table frame.

le allunghe possono essere posizionate all'interno del tavolo.
the extensions can be positioned inside the table.
les rallonges peuvent  tre plac es   l'int rieur de la table.
die Verl ngerungen k nnen innerhalb des Tisches gelegt werden.
las extensiones pueden colocarse dentro de la mesa.

PANCHE ALLUNGABILI / EXTENDABLE BENCHES / BANCS EXTENSIBLES
AUSZIEHBARE B NKE / BANQUILLOS EXTENSIBLES

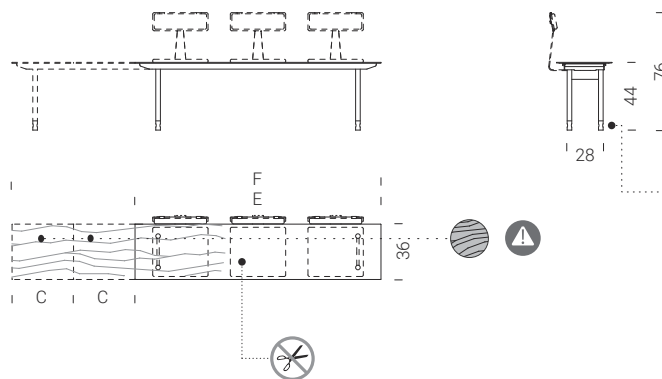

	E / F x 36	C		S05	S06	L08	Y36
				S07	L03	L10	Y34
				S08	L06	L11	Y37
							Y39
							Y40
8PAN0002	160 / 240 x 36	40+40	3 (4)	2007	1825	1872	2056
8PAN0003	200 / 280 x 36	40+40	3 (5)	2486	2260	2317	2537
8PAN0015	230 / 310 x 36	40+40	3 (5)	2982	2711	2781	3044

❗ piedi disponibili in ottone **C31**, ottone scuro **C32** o verniciato a polveri nella finitura del telaio della panca.
feet available in **C31** brass, **C32** dark brass or painted steel in the finish of the bench frame.

schienali e cuscini non inclusi nel prezzo, info pagina 165
backrests and cushions not included in the price, info on page 165
dossiers et coussins non inclus dans le prix, info page 165
R ckenteile und Kissen nicht im Preis inbegriffen, Info Seite 165
respaldos y cojines no incluidos en el precio, p gina de informaci n 165

impiallacciatura continua su top e allunghe
continues veneer on top and extensions
les veines du placage bois suivent sur les rallonges
sauberer Furnierverlauf  ber Tisch- und Verl ngerungsplatte
chapa de madera contin a en el plano y extensiones

top e allunghe nella stessa finitura
top and extensions with the same finish
plateau et rallonges dans la m me finition
Abdeck- und Ausziehplatten in derselben Vollendung
Encimera y extensiones en el mismo acabado

Apertura allunghe
Opening of extensions
Ouverture de rallonges
 ffnung verl ngerungsst cke
Apertura de la extensi n

acciaio verniciato/painted steel/acier peint
lackierter Stahl/acero pintado

- C12** bianco/white
- C21** seta/silk
- C23** corda/ecru
- C30** ghisa/cast-iron
- C14** antracite/anthracite
- C08** nero/black
- C18** verde/green
- C26** corten/corten
- C29** bronzo/bronze
- C37** rame/copper
- C38** titanio/titanium

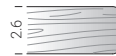

- legno massiccio/solid wood
bois massif/Massivholz
madera maciza
- T01** rovere/oak
 - T02** noce/walnut
 - T03** iroko
 - T04** iroko outdoor
 - T05** rovere nero/black oak

- ceramica/ceramic/c eramique
Keramik/cer mico
- S05** antracite/anthracite
 - S06** nero/black
 - S07** porfido/porfido
 - S08** cardoso/cardoso

- HPL POLARIS®
- L03** bianco/white
 - L10** grigio chiaro/light grey
 - L11** grigio scuro/dark grey
- HPL FENIX®
- L08** grigio Londra/London grey
 - L06** nero/black

- HPL+ cemento/concrete/ciment
zement/cemento
- D01** bianco calce/lime white
 - D02** grigio Portland/Portland grey
 - D03** nero/black
- HPL+ metallo/metal/m tal/Metall/metal
- C31** ottone/brass
 - C32** ottone scuro/dark brass
 - C35** inox/inox
 - C36** inox scuro/dark inox

- HPL+ legno/wood/bois/Holz/madera
- Y36** rovere/oak
 - Y34** noce/walnut
 - Y37** rovere affumicato/smoked oak
 - Y39** frassino nero/black ash
 - Y40** frassino argilla/clay ash
- HPL+ ecotouch
- N01** sabbia/sand
 - N02** basalto/basalt

TAVOLI RETTANGOLARI / RECTANGULAR TABLES / TABLES RECTANGULAIRES
RECHTECKIGE TISCHE / MESAS RECTANGULARES

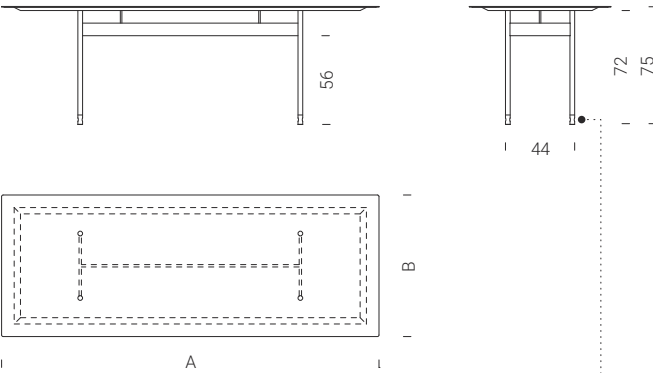

	A x B		T01 T03 T04	T02 T05	S05 S06	S07 S08	L03 L06	L08 L10 L11	D01 D02 D03	C31 C32 C35 C36	Y36 Y34 Y37 Y39 Y40	N01 N02		
8TAV0004	120 x 78	4	1588	1723	1654	1654	1449	1525	1681	2124	1660	1558	961	+173
8TAV0006	160 x 78	6	2016	2069	1852	1852	1625	1721	1888	2483	1868	1724	1078	+173
8TAV0008	180 x 78	8	2150	2218	1990	1990	1728	1833	2007	2670	1987	1822	1146	+173
8TAV0011	200 x 78	8	2277	2400	2149	2149	1865	1991	2179	2913	2158	1976	1196	+269
8TAV0005	120 x 90	6	1830	1857	1701	1701	1484	1569	1723	2234	1704	1581	984	+173
8TAV0007	160 x 90	6	2144	2225	2002	2002	1742	1850	2024	2701	2005	1835	1155	+173
8TAV0009	180 x 90	8	2295	2396	2187	2187	1938	2056	2210	2970	2203	1998	1287	+173
8TAV0012	200 x 90	8	2458	2597	2312	2312	1998	2138	2334	3169	2314	2100	1326	+269
8TAV0014	220 x 90	8	2646	2799	2434	2434	2131	2284	2489	3682	2469	2229	1366	+269
8TAV0016	240 x 90	10	2841	3246	2710	2710	2346	2511	2738	4029	2716	2454	1504	+269
8TAV0010	180 x 98	8	2404	2531	2239	2239	1947	2074	2262	3087	2243	2030	1291	+173
8TAV0013	200 x 98	8	2474	2754	2425	2425	2098	2248	2451	3356	2431	2196	1345	+269
8TAV0015	220 x 98	8	2654	2963	2575	2575	2246	2410	2624	3918	2604	2340	1440	+269
8TAV0017	240 x 98	10	2849	3253	2852	2852	2473	2650	2885	4286	2863	2576	1585	+269
8TAV0018	300 x 98	12	3579	3788	3336	3336	2922	3134	3407	5150	3383	3022	1873	+269

pedi disponibili in ottone **C31**, ottone scuro **C32** o verniciato a polveri nella finitura del telaio del tavolo.
feet available in **C31** brass, **C32** dark brass or painted steel in the finish of the table frame.

PANCHE FISSE / FIXED BENCHES / BANCS FIXES
FESTE B NKE / BANQUILLOS FIJOS

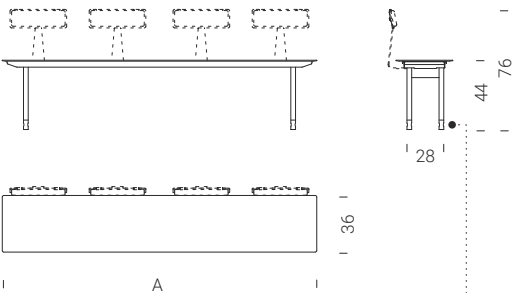

	A x B													
8PAN0004	120 x 36	2	1396	1465	1107	1107	923	986	1078	1530	1097	972	953	+173
8PAN0014	140 x 36	2	1428	1497	1141	1141	951	1015	1110	1576	1130	1000	953	+173
8PAN0005	160 x 36	3	1460	1531	1159	1159	966	1031	1127	1598	1147	1015	953	+173
8PAN0006	180 x 36	3	1523	1598	1209	1209	1008	1076	1176	1668	1197	1060	953	+173
8PAN0007	200 x 36	3	1600	1677	1269	1269	1058	1130	1235	1752	1257	1113	953	+228
8PAN0008	220 x 36	3	1643	1723	1303	1303	1086	1160	1268	1799	1290	1143	953	+228
8PAN0009	240 x 36	4	1892	1983	1501	1501	1251	1336	1460	2072	1486	1316	953	+228
8PAN0010	300 x 36	5	1911	2004	1516	1516	1264	1350	1475	2092	1501	1329	953	+228

pedi disponibili in ottone **C31**, ottone scuro **C32** o verniciato a polveri nella finitura del telaio del tavolo.
feet available in **C31** brass, **C32** dark brass or painted steel in the finish of the table frame.

maggiorazione per esterno riparato solo per surcharge for sheltered outdoor only for majoration pour ext rieur prot g  juste pour Zuschlag f r drau en gesch tzt nur f r aumento para exterior reparado solo para

- T04 S05 D01 L03 L08 C35**
S06 D02 L06 L10 C36
S07 D03 L11
S08

solo telaio (info pg.100)
frame only (info on pg.100)
seulement b ti (info pg.100)
Ausschlie lich Rahmen (Info pg.100)
solo marco (informaci n pg.100)

accessori non inclusi, disponibili a pg.165
accessories not included, available on pg.165
Accessoires non inclus, disponibles pg.165
Zubeh r nicht inbegriffen, erh ltlich auf pg.165
accesorios no incluidos, disponibles en pg.165

disponibili riduzioni a misura
tailor-made reduction available
disponibles r ductions sur mesure
Verkleinerung nach Kundenwunsch
disponibles reducciones a medida

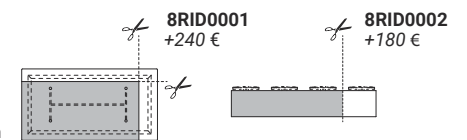

acciaio verniciato/painted steel/acier peint
lackierter Stahl/acero pintado

- C12** bianco/white
- C21** seta/silk
- C23** corda/ecru
- C30** ghisa/cast-iron
- C14** antracite/anthracite
- C08** nero/black
- C18** verde/green
- C26** corten/corten
- C29** bronzo/bronze
- C37** rame/copper
- C38** titanio/titanium

legno massiccio/solid wood
bois massif/Massivholz
madera maciza

- T01** rovere/oak
- T02** noce/walnut
- T03** iroko
- T04** iroko outdoor
- T05** rovere nero/black oak

ceramica/ceramic/c eramique
Keramik/cer mico

- S05** antracite/anthracite
- S06** nero/black
- S07** porfido/porfido
- S08** cardoso/cardoso

HPL POLARIS®

- L03** bianco/white
- L10** grigio chiaro/light grey
- L11** grigio scuro/dark grey

HPL FENIX®

- L08** grigio Londra/London grey
- L06** nero/black

HPL+ cemento/concrete/ciment
zement/cemento

- D01** bianco calce/lime white
- D02** grigio Portland/Portland grey
- D03** nero/black

HPL+ metallo/metal/m tal/Metall/metal

- C31** ottone/brass
- C32** ottone scuro/dark brass
- C35** inox/inox
- C36** inox scuro/dark inox

HPL+ legno/wood/bois/Holz/madera

- Y36** rovere/oak
- Y34** noce/walnut
- Y37** rovere affumicato/smoked oak
- Y39** frassino nero/black ash
- Y40** frassino argilla/clay ash

HPL+ ecotouch

- N01** sabbia/sand
- N02** basalto/basalt

TAVOLI A TESTA TONDA / ROUND HEAD TABLES / TABLES AUX EXTR MIT S ARRONDIES
RUNDER KOPF TISCHE / MESAS REDONDAS DE ESTRUCTURA LINEAL

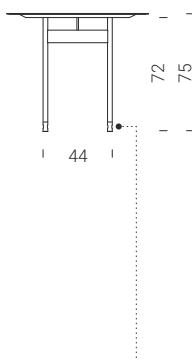
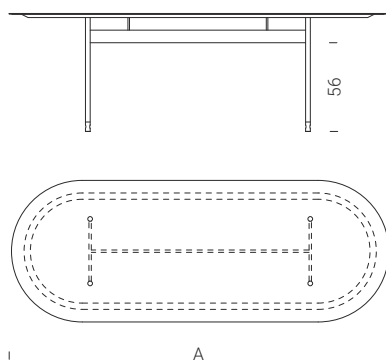

	A x B		T01 T03 T04	T02 T05	S05 S06	S07 S08	L03 L06	L08 L10 L11	D01 D02 D03	C31 C32 C35 C36	Y36 Y34 Y37 Y39 Y40	N01 N02		
8TAV0019	180 x 78	8	2150	2218	1990	1990	1728	1833	2007	2670	1987	1822	1146	+173
8TAV0022	200 x 78	8	2277	2400	2149	2149	1865	1991	2179	2913	2158	1976	1196	+269
8TAV0020	180 x 90	8	2295	2396	2187	2187	1938	2056	2210	2970	2203	1998	1287	+173
8TAV0023	200 x 90	8	2458	2597	2312	2312	1998	2138	2334	3169	2314	2100	1326	+269
8TAV0025	220 x 90	8	2646	2799	2434	2434	2131	2284	2489	3682	2469	2229	1366	+269
8TAV0027	240 x 90	10	2841	3246	2710	2710	2346	2511	2738	4029	2716	2454	1504	+269
8TAV0021	180 x 98	8	2404	2531	2239	2239	1947	2074	2262	3087	2243	2030	1291	+173
8TAV0024	200 x 98	8	2474	2754	2425	2425	2098	2248	2451	3356	2431	2196	1345	+269
8TAV0026	220 x 98	8	2654	2963	2575	2575	2246	2410	2624	3918	2604	2340	1440	+269
8TAV0028	240 x 98	10	2849	3253	2852	2852	2473	2650	2885	4286	2863	2576	1585	+269
8TAV0029	300 x 98	12	3579	3788	3336	3336	2922	3134	3407	5150	3383	3022	1873	+269

pedi disponibili in ottone **C31**, ottone scuro **C32** o verniciato a polveri nella finitura del telaio del tavolo.
feet available in **C31** brass, **C32** dark brass or painted steel in the finish of the table frame.

TAVOLI A BOTTE / BARREL VAULT TABLES / TABLES TONNEAU
WEINFASS-TISCHE / MESAS DE BARRIL

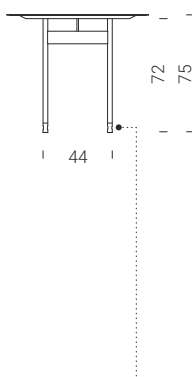
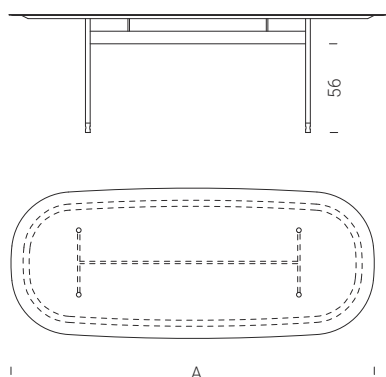

	A x B		T01 T03 T04	T02 T05	S05 S06	S07 S08	L03 L06	L08 L10 L11	D01 D02 D03	C31 C32 C35 C36	Y36 Y34 Y37 Y39 Y40	N01 N02		
8TAV0030	180 x 98	8	2404	2531	2239	2239	1947	2074	2262	3087	2243	2030	1291	+173
8TAV0032	200 x 98	8	2474	2754	2425	2425	2098	2248	2451	3356	2431	2196	1345	+269
8TAV0034	220 x 98	8	2654	2963	2575	2575	2246	2410	2624	3918	2604	2340	1440	+269
8TAV0036	240 x 98	10	2849	3253	2852	2852	2473	2650	2885	4286	2863	2576	1585	+269
8TAV0038	300 x 98	12	3579	3788	3336	3336	2922	3134	3407	5150	3383	3022	1873	+269
8TAV0031	180 x 105	8	2596	2733	2418	2418	2102	2239	2442	3333	2422	2192	1394	+173
8TAV0033	200 x 105	8	2722	3029	2667	2667	2308	2473	2696	3692	2674	2415	1479	+269
8TAV0035	220 x 105	8	2920	3259	2832	2832	2471	2651	2886	4309	2864	2574	1584	+269
8TAV0037	240 x 105	10	3088	3458	3137	3137	2720	2914	3174	4715	3150	2834	1744	+269
8TAV0039	300 x 105	12	3936	4167	3670	3670	3215	3447	3747	5665	3721	3325	2061	+269

pedi disponibili in ottone **C31**, ottone scuro **C32** o verniciato a polveri nella finitura del telaio del tavolo.
feet available in **C31** brass, **C32** dark brass or painted steel in the finish of the table frame.

maggiorazione per esterno riparato solo per surcharge for sheltered outdoor only for majoration pour ext rieur prot g  juste pour Zuschlag f r drau en gesch tzt nur f r aumento para exterior reparado solo para

T04 S05 D01 L03 L08 C35
S06 D02 L06 L10 C36
S07 D03 L11
S08

solo telaio (info pg.100)
frame only (info on pg.100)
seulement b ti (info pg.100)
Ausschlie lich Rahmen (Info pg.100)
solo marco (informaci n pg.100)

accessori disponibili a pg.166
accessories available on pg.166
accessoires disponibles pg.166
erh ltliches Zubeh r auf pg.166
accesorios disponibles en pg.166

disponibili riduzioni a misura
tailor-made reduction available
disponibles r ductions sur mesure
Verkleinerung nach Kundenwunsch
disponibles reducciones a medida

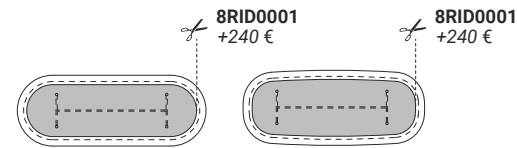

acciaio verniciato/painted steel/acier peint
lackierter Stahl/acero pintado

- C12** bianco/white
- C21** seta/silk
- C23** corda/ecru
- C30** ghisa/cast-iron
- C14** antracite/anthracite
- C08** nero/black
- C18** verde/green
- C26** corten/corten
- C29** bronzo/bronze
- C37** rame/copper
- C38** titanio/titanium



- legno massiccio/solid wood
bois massif/Massivholz
madera maciza
- T01** rovere/oak
 - T02** noce/walnut
 - T03** iroko
 - T04** iroko outdoor
 - T05** rovere nero/black oak

- ceramica/ceramic/c eramique
Keramik/cer mico
- S05** antracite/anthracite
 - S06** nero/black
 - S07** porfido/porfido
 - S08** cardoso/cardoso

- HPL POLARIS®
- L03** bianco/white
 - L10** grigio chiaro/light grey
 - L11** grigio scuro/dark grey
- HPL FENIX®
- L08** grigio Londra/London grey
 - L06** nero/black

- HPL+ cemento/concrete/ciment
zement/cemento
- D01** bianco calce/lime white
 - D02** grigio Portland/Portland grey
 - D03** nero/black
- HPL+ metallo/metal/m tal/Metall/metal
- C31** ottone/brass
 - C32** ottone scuro/dark brass
 - C35** inox/inox
 - C36** inox scuro/dark inox

- HPL+ legno/wood/bois/Holz/madera
- Y36** rovere/oak
 - Y34** noce/walnut
 - Y37** rovere affumicato/smoked oak
 - Y39** frassino nero/black ash
 - Y40** frassino argilla/clay ash
- HPL+ ecotouch
- N01** sabbia/sand
 - N02** basalto/basalt

**TAVOLI OVALI / OVAL TABLES / TABLES OVALES
OVALTISCHE / MESAS OVALADAS**

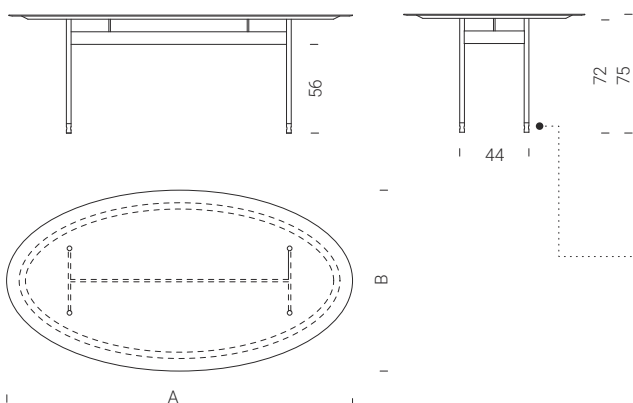

	A x B		T01 T03 T04	T02 T05	S05 S06	S07 S08	L03 L06	L08 L10 L11	D01 D02 D03	C31 C32 C35 C36	Y36 Y34 Y37 Y39 Y40	N01 N02		
8TAV0040	160 x 85	6	2051	2135	1964	1964	1646	1748	1912	2540	1894	1734	1055	+173
8TAV0041	180 x 95	8	2368	2473	2231	2231	1878	2003	2124	2975	2166	1959	1204	+173
8TAV0042	200 x 105	8	2649	2950	2554	2554	2145	2305	2507	3755	2489	2231	1375	+269
8TAV0043	220 x 115	8	3028	3390	2905	2905	2447	2634	2857	4354	2840	2524	1569	+269
8TAV0044	248 x 128	10	3200	3674	3123	-	2953	3180	-	-	3426	3027	1893	+269

piedi disponibili in ottone **C31**, ottone scuro **C32** o verniciato a polveri nella finitura del telaio del tavolo.
feet available in **C31** brass, **C32** dark brass or painted steel in the finish of the table frame.

**TAVOLI TONDI / ROUND TABLES / TABLES RONDES
RUNDTISCHE TISCHE / MESAS REDONDAS**

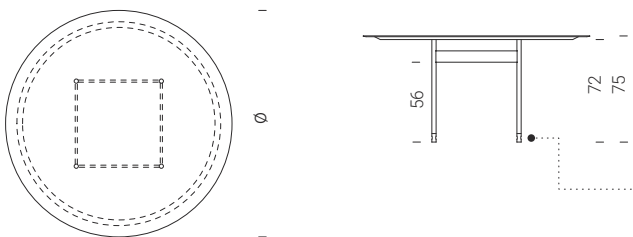

	�		T01 T03 T04	T02 T05	S05 S06	S07 S08	L03 L06	L08 L10 L11	D01 D02 D03	C31 C32 C35 C36	Y36 Y34 Y37 Y39 Y40	N01 N02		
8TAV0045	128	6	2252	2486	2133	-	1856	1988	-	-	2151	1955	1190	+173
8TAV0046	140	7	2666	2795	2334	-	2030	2159	-	-	2332	2092	1302	+269
8TAV0047	160	8	2918	3152	2738	-	2382	2539	-	-	2736	2414	1527	+269

piedi disponibili in ottone **C31**, ottone scuro **C32** o verniciato a polveri nella finitura del telaio del tavolo.
feet available in **C31** brass, **C32** dark brass or painted steel in the finish of the table frame.

maggiorazione per esterno riparato solo per surcharge for sheltered outdoor only for majoration pour ext rieur prot g e juste pour Zuschlag f r drau en gesch tzt nur f r aumento para exterior reparado solo para

- T04 S05 D01 L03 L08 C35
S06 D02 L06 L10 C36
S07 D03 L11
S08**

solo telaio (info pg.100)
frame only (info on pg.100)
seulement b ti (info pg.100)
Ausschlie lich Rahmen (Info pg.100)
solo marco (informaci n pg.100)

accessori disponibili a pg.166
accessories available on pg.166
accessoires disponibles pg.166
erh ltliches Zubeh r auf pg.166
accesorios disponibles en pg.166

disponibili riduzioni a misura
tailor-made reduction available
disponibles r ductions sur mesure
Verkleinerung nach Kundenwunsch
disponibles reducciones a medida

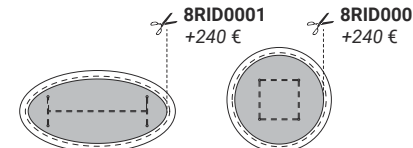

acciaio verniciato/painted steel/acier peint
lackierter Stahl/acero pintado

- C12** bianco/white
- C21** seta/silk
- C23** corda/ecru
- C30** ghisa/cast-iron
- C14** antracite/anthracite
- C08** nero/black
- C18** verde/green
- C26** corten/corten
- C29** bronzo/bronze
- C37** rame/copper
- C38** titanio/titanium

legno massiccio/solid wood
bois massif/Massivholz
madera maciza

- T01** rovere/oak
- T02** noce/walnut
- T03** iroko
- T04** iroko outdoor
- T05** rovere nero/black oak

ceramica/ceramic/c eramique
Keramik/cer mico

- S05** antracite/anthracite
- S06** nero/black
- S07** porfido/porfido
- S08** cardoso/cardoso

HPL POLARIS®

- L03** bianco/white
- L10** grigio chiaro/light grey
- L11** grigio scuro/dark grey

HPL FENIX®

- L08** grigio Londra/London grey
- L06** nero/black

HPL+ cemento/concrete/ciment
zement/cemento

- D01** bianco calce/lime white
- D02** grigio Portland/Portland grey
- D03** nero/black

HPL+ metallo/metal/m tal/Metall/metal

- C31** ottone/brass
- C32** ottone scuro/dark brass
- C35** inox/inox
- C36** inox scuro/dark inox

HPL+ legno/wood/bois/Holz/madera

- Y36** rovere/oak
- Y34** noce/walnut
- Y37** rovere affumicato/smoked oak
- Y39** frassino nero/black ash
- Y40** frassino argilla/clay ash

HPL+ ecotouch

- N01** sabbia/sand
- N02** basalto/basalt

**TAVOLI QUADRATI A BOTTE / SQUARE BARREL TABLES / TABLES   TONNEAU CARR ES
VIERECKIGE TONNENF RMIGE TISCHE / MESAS CUADRADAS**

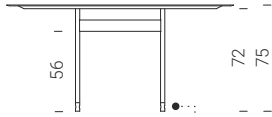
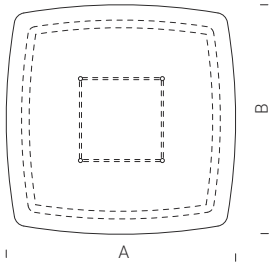

	A x B		T01 T03 T04	T02 T05	S05 S06	S07 S08	L03 L06	L08 L10 L11	D01 D02 D03	C31 C32 C35 C36	Y36 Y34 Y37 Y39 Y40	N01 N02		
8TAV0051	120 x 120	6	2302	2423	2148	2148	1864	1986	2166	2956	2149	1944	1370	+173
8TAV0052	140 x 140	8	2592	2739	2423	-	2108	2296	-	-	2480	2202	1447	+269

piedi disponibili in ottone **C31**, ottone scuro **C32** o verniciato a polveri nella finitura del telaio del tavolo.
feet available in **C31** brass, **C32** dark brass or painted steel in the finish of the table frame.

TAVOLI QUADRATI / SQUARE TABLES / TABLES CARR ES / QUADRATISCHE TISCHE / MESAS CUADRADAS

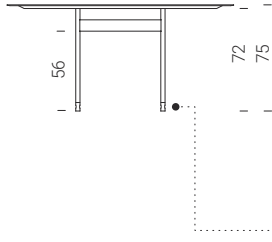
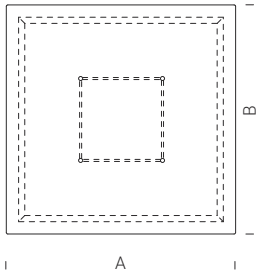

	A x B		T01 T03 T04	T02 T05	S05 S06	S07 S08	L03 L06	L08 L10 L11	D01 D02 D03	C31 C32 C35 C36	Y36 Y34 Y37 Y39 Y40	N01 N02		
8TAV0063	78 x 78	2	1432	1519	1395	1395	1231	1282	1420	1696	1399	1340	789	+173
8TAV0064	90 x 90	4	1462	1527	1562	1526	1369	1437	1585	1954	1565	1479	878	+173
8TAV0065	98 x 98	4	1822	1902	1669	1669	1452	1533	1690	2127	1669	1564	963	+173
8TAV0053	120 x 120	6	2302	2423	2148	2148	1864	1986	2166	2956	2149	1944	1370	+173
8TAV0054	140 x 140	8	2592	2739	2423	-	2108	2296	-	-	2480	2202	1447	+269

piedi disponibili in ottone **C31**, ottone scuro **C32** o verniciato a polveri nella finitura del telaio del tavolo.
feet available in **C31** brass, **C32** dark brass or painted steel in the finish of the table frame.

maggiorazione per esterno riparato solo per surcharge for sheltered outdoor only for majoration pour ext rieur prot g  juste pour Zuschlag f r drau en gesch tzt nur f r aumento para exterior reparado solo para

**T04 S05 D01 L03 L08 C35
S06 D02 L06 L10 C36
S07 D03 L11
S08**

solo telaio (info pg.100)
frame only (info on pg.100)
seulement b ti (info pg.100)
Ausschlie lich Rahmen (Info pg.100)
solo marco (informaci n pg.100)

accessori disponibili a pg.166
accessories available on pg.166
accessoires disponibles pg.166
erh ltliches Zubeh r auf pg.166
accesorios disponibles en pg.166

disponibili riduzioni a misura
tailor-made reduction available
disponibles r ductions sur mesure
Verkleinerung nach Kundenwunsch
disponibles reducciones a medida

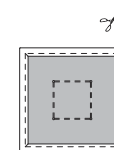

8RID0001
+240  

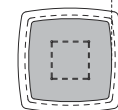

8RID0001
+240  

acciaio verniciato/painted steel/acier peint
lackierter Stahl/acero pintado

- C12** bianco/white
- C21** seta/silk
- C23** corda/ecru
- C30** ghisa/cast-iron
- C14** antracite/anthracite
- C08** nero/black
- C18** verde/green
- C26** corten/corten
- C29** bronzo/bronze
- C37** rame/copper
- C38** titanio/titanium



legno massiccio/solid wood
bois massif/Massivholz
madera maciza

- T01** rovere/oak
- T02** noce/walnut
- T03** iroko
- T04** iroko outdoor ☀️
- T05** rovere nero/black oak

TAVOLI DOGATI / SLATTED TABLES / TABLES À LATTES
DAUBEN-TISCHE / MESAS LAMINADAS

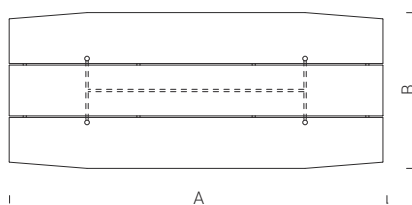
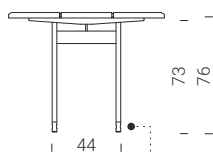
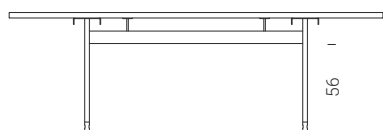

piedi disponibili in ottone **C31**, ottone scuro **C32** o verniciato a polveri nella finitura del telaio del tavolo.
feet available in **C31** brass, **C32** dark brass or painted steel in the finish of the table frame.

	A x B		T01 T03	T02 T05	
8TAV0048	180 x 100	6	3455	3795	3628
8TAV0049	240 x 100	10	4096	4879	4365
8TAV0050	300 x 100	12	5144	5682	5413

PANCHE DOGATE / SLATTED BENCHES / BANCS À LATTES
DAUBEN-BÄNKE / BANCOS LAMINADOS

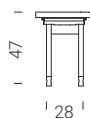

piedi disponibili in ottone **C31**, ottone scuro **C32** o verniciato a polveri nella finitura del telaio della panca.
feet available in **C31** brass, **C32** dark brass or painted steel in the finish of the bench frame.

	A x B		T01 T03	T02 T05	
8PAN0011	180 x 36	3	1675	1725	1848
8PAN0012	240 x 36	4	2081	2141	2309
8PAN0013	300 x 36	5	2102	2164	2330



esterno **T04**
outdoor **T04**
extérieur **T04**
draußen **T04**
exterior **T04**



solo telaio (info pg.100)
frame only (info on pg.100)
seulement bâti (info pg.100)
Ausschließlich Rahmen (Info pg.100)
solo marco (información pg.100)



disponibili riduzioni a misura
tailor-made reduction available
disponibles réductions sur mesure
Verkleinerung nach Kundenwunsch
disponibles reducciones a medida

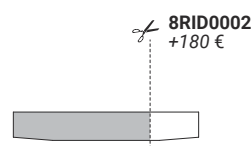
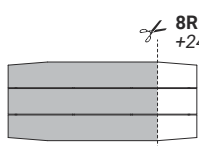

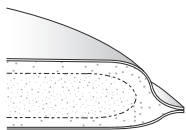

cuoio/cow-hide/cuir
Kernleder/cuero
F01 tabacco/tobacco
F02 nero/black

**CUSCINO PER PANCA / BENCH CUSHION / COUSSIN POUR BANC
BANKKISSEN / COJÍN PARA BANQUILLO**

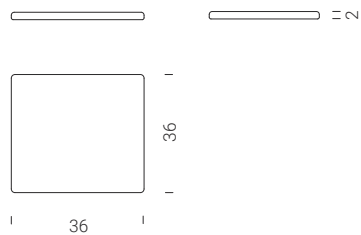
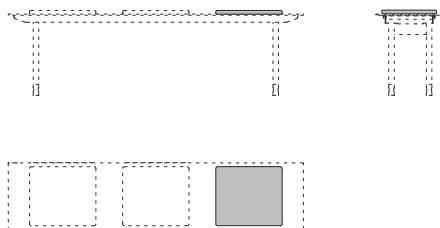

	F01
	F02
OACC0001	132

**SCHIENALE CON CUSCINO / BACKREST WITH CUSHION / DOSSIER AVEC COUSSIN
RÜCKENLEHNE MIT KISSEN / RESPALDO CON COJÍN**

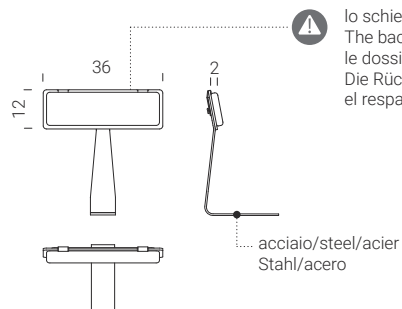
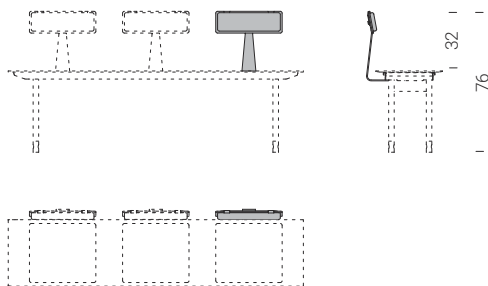

⚠ lo schienale ha le stesse finiture della panca
The backrest has the same finishes as the bench
le dossier a les mêmes finitions que le banc
Die Rückenlehne wird wie die Bank vollendet
el respaldo tiene los mismos acabados que el banco

acciaio/steel/acier
Stahl/acero

	F01
	F02
OACC0002	232

cuscino incluso
cushion included
coussin inclus
kissen enthalten
cojin incluido

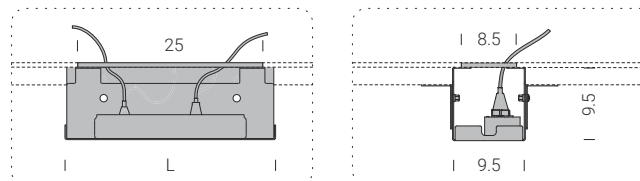
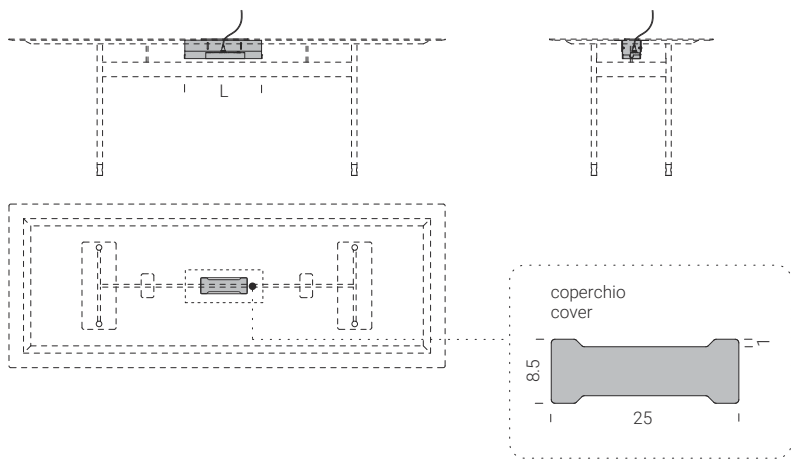
PASSACAVO / CABLE GLAND / PASSE-CÂBLE / KABELDURCHLASS / PASACABLES

cesto in acciaio e copertura magnetica nelle finiture del tavolo.
 steel basket and magnetic cover in the table finishings.
 panier en acier et couvercle magnétique dans les mêmes finitions que la table.
 Stahlkorb und Magnetabdeckung in der Tischausführung.
 cesto de acero y cubierta magnética en los acabados de la mesa.

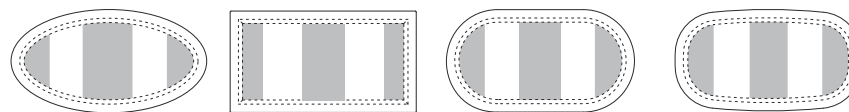

Il passacavi può essere posizionato esclusivamente nelle aree evidenziate.
 the cable tidy can be placed only in the highlighted areas
 le passe-câbles peut être placé que dans le domaines mis en évidence
 das Kabeldurchführung kann nur in den hervorgehobenen Bereichen angeordnet werden
 el pasacables se puede colocar sólo en las áreas resaltadas

	L	
SACC0003	28	185
SACC0004	40	205

vedi catalogo a pg.156
 refer to catalogue pg.156
 Voir catalogue pg. 156
 siehe Katalog auf pg.156
 véase pg.156 del catálogo

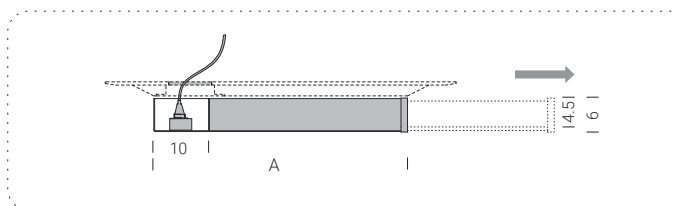
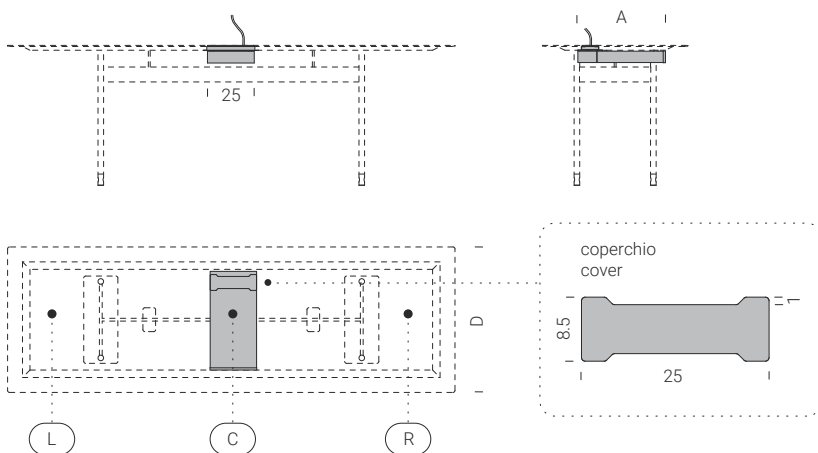
**CASSETTO CON PASSACAVO / DRAWER WITH CABLE GLAND / TIROIR AVEC PASSE-CÂBLE
 SCHUBLADE MIT KABELDURCHLASS / CAJÓN CON PASACABLES**

cassetto in acciaio e frontale nelle finiture del tavolo. (il prezzo include la foratura del top tavolo).
 steel drawer and front in the table finishings. (the price includes perforation of the table top).
 tiroir en acier et façade dans les mêmes finitions que la table. (le prix inclut le perçage du plateau de la table).
 Stahlschublade und Vorderseite in den Tischausführungen. (Die Bohrung der Tischplatte ist im Preis inbegriffen).
 cajón de acero y frontal en los acabados de la mesa. (el precio incluye el perforado de la encimera).

ordinabile in posizione L (sinistra), R (destra), C (centrale).
 available in the following positions: L (left), R (right), C (central).
 peut être commandé en position L (gauche), R (droite), C (centrale).
 aufstellbar in Position L (links), R (rechts), C (Mitte).
 disponible en posición L (izquierda), R (derecha), C (central).

	A x B x C (D)	
GACC0001	47 x 25 x 6 (65)	260
GACC0002	53 x 25 x 6 (78)	280
GACC0003	68 x 25 x 6 (90)	320

vedi catalogo a pg.200 / refer to catalogue pg.200
 Voir catalogue pg.200 / siehe Katalog auf pg.200
 véase pg.200 del catálogo



ceramica/ceramic/c eramique
Keramik/cer amico

- S05** antracite/anthracite
- S06** nero/black
- S07** porfido/porfido
- S08** cardoso/cardoso



HPL POLARIS®

- L03** bianco/white
- L10** grigio chiaro/light grey
- L11** grigio scuro/dark grey

HPL FENIX®

- L08** grigio Londra/London grey
- L06** nero/black



HPL+ cemento/concrete/ciment
zement/cemento

- D01** bianco calce/lime white
- D02** grigio Portland/Portland grey
- D03** nero/black

HPL+ metallo/metal/m etal/Metall/metal

- C31** ottone/brass
- C32** ottone scuro/dark brass
- C35** inox/inox
- C36** inox scuro/dark inox

CASSETTO / DRAWER / TIROIR / SCHUBLADE / CAJ N

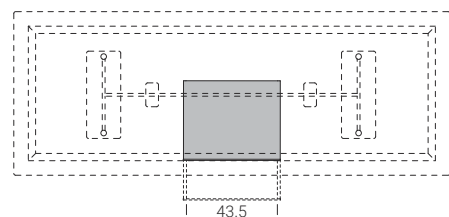
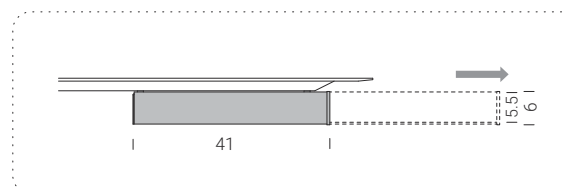
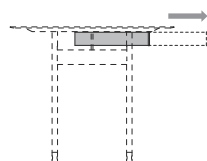
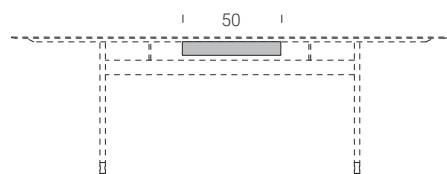

A x B x C

SACC0006	50 x 41 x 6	368
-----------------	-------------	-----

vedi catalogo a pg.206
refer to catalogue pg.206
Voir catalogue pg.206
siehe Katalog auf pg.206
v ase pg.206 del cat logo

scocca in acciaio e frontale nelle finiture del tavolo.
Steel body and front in the table finishings.
coque en acier et fa ade dans les m mes finitions que la table.
Stahlaufbau und Vorderseite in den Tischausf hrungen.
chapa de acero y frontal en los acabados de la mesa.

- ⚠ disponibile per tavoli a partire da lunghezza 220 cm
available for tables at least 220 cm long
disponible pour des tables   partir d'une longueur de 220 cm
Erh ltlich f r Tische ab einer Tischl nge von 220 cm
disponible para mesas desde 220 cm de longitud

VASSOI / TRAYS / PLATEAUX / TABLETS / BANDEJAS

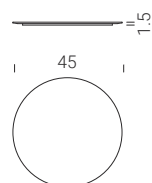

S05					C31
S06					C32
S07	L03	L08	D01		C35
S08	L06	L11	D03		C36

SACC0007	45 x 1.5	190	165	180	205	245
-----------------	----------	-----	-----	-----	-----	-----

vedi catalogo a pg.172 / refer to catalogue pg.172
Voir catalogue pg. 172 / siehe Katalog auf pg.172
v ase pg.172 del cat logo

T9

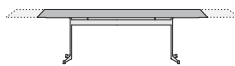

IL TAGLIO LASER SU ACCIAIO DI SPESSORE 8MM E LA PRESSO-PIEGATURA CONSENTONO DI RIDURRE AL MINIMO L'INGOMBRO DEL SUPPORTO AUMENTANDO LO SPAZIO UTILE ALLE SEDIE E DI CONSEGUENZA LA FRUIBILITÀ COMPLESSIVA DEL TAVOLO. T9 È DISPONIBILE IN VERSIONE FISSA E ALLUNGABILE. LA VERSIONE FISSA È CONFIGURABILE CON 8 GEOMETRIE DI TOP DISPONIBILI IN 8 CATEGORIE DI FINITURE, MENTRE PER I BASAMENTI LA SCELTA È TRA 11 COLORAZIONI A POLVERI.

Laser cutting on 8 mm thick steel and press-bending allow minimization of the overall size of the support, increasing the space for the chairs and, consequently, the overall use of the table. T9 is available in the fixed and extending version. The fixed version can have 8 geometries of top in 8 types of finish, while for the bases there is a choice of 11 powder coated colours

La découpe au laser sur acier de 8 mm d'épaisseur et le pliage à la presse permettent de réduire les dimensions du support au minimum, augmentant ainsi l'espace utile aux assises pour utiliser pleinement la table. T9 est disponible en version fixe et extensible. La version fixe peut être configurée en choisissant parmi 8 formes de plateau, disponibles en 8 catégories de finitions, tandis que 11 couleurs de poudre sont disponibles pour les socles.

Das Laserschneiden auf 8 mm dickem Stahl und das Faltpressen ermöglichen es, die Größe der Stütze auf das Minimum zu reduzieren und so den brauchbaren Raum für die Stühle zu vergrößern und infolgedessen die Verwendbarkeit des Tisches zu optimieren. T9 ist in fester und ausdehnbarer Version verfügbar. Die feste Version kann mit 8 Tischplattenformen, verfügbar in 8 Beschichtungskategorien, konfiguriert werden, während für den Sockel zwischen 11 Pulverfärbungen gewählt werden kann.

El corte láser en acero de 8 mm de grosor y el plegado a presión permiten reducir al mínimo las dimensiones del soporte, lo que aumenta el espacio disponible para las sillas y, en consecuencia, la utilidad general de la mesa. La T9 está disponible en versión fija y extensible. La versión fija puede configurarse con 8 geometrías de tablero disponibles en 8 categorías de acabados, mientras que para las bases se puede elegir entre 11 colores con recubrimiento pulverizado.



Disponibili riduzioni a misura
Custom reductions available
Réductions sur mesure disponibles
Verkürzungen auf Maß erhältlich
Disponibles reducciones a medida



Passacavo disponibile per tutti i top
Cable gland available for all tops
Passe-câble disponible pour tous les plateaux
Kabeldurchlass für alle Abschlussborde verfügbar
Pasacables disponible para todos los sobros



Piedini regolabili in acciaio inox.
Adjustable feet in stainless steel.
Pieds réglables en acier inox.
Regulierbaren Edelstahlfüßchen.
Patas regulables de acero inoxidable



EXTENDABLE
TABLE SYSTEM
registered community
design



acciaio verniciato/painted steel/acier peint
lackierter Stahl/acero pintado

- C12** bianco/white
- C21** seta/silk
- C23** corda/ecru
- C30** ghisa/cast-iron
- C14** antracite/anthracite
- C08** nero/black
- C18** verde/green
- C26** corten/corten
- C29** bronzo/bronze
- C37** rame/copper
- C38** titanio/titanium

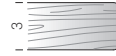

legno massiccio/solid wood
bois massif/Massivholz
madera maciza

- T01** rovere/oak
- T02** noce/walnut
- T03** iroko
- T04** iroko outdoor
- T05** rovere nero/black oak



ceramica/ceramic/c ramique
Keramik/cer mico

- S05** antracite/anthracite
- S06** nero/black
- S07** porfido/porfido
- S08** cardoso/cardoso



HPL POLARIS®

- L03** bianco/white
- L10** grigio chiaro/light grey
- L11** grigio scuro/dark grey

HPL FENIX®

- L08** grigio Londra/London grey
- L06** nero/black



HPL+ legno/wood/bois/Holz/madera

- Y36** rovere/oak
- Y34** noce/walnut
- Y37** rovere affumicato/smoked oak
- Y39** frassino nero/black ash
- Y40** frassino argilla/clay ash

TAVOLI ALLUNGABILI / EXTENDABLE TABLES / TABLES EXTENSIBLES AUSZIEHBARE TISCHE / MESAS EXTENSIBLES

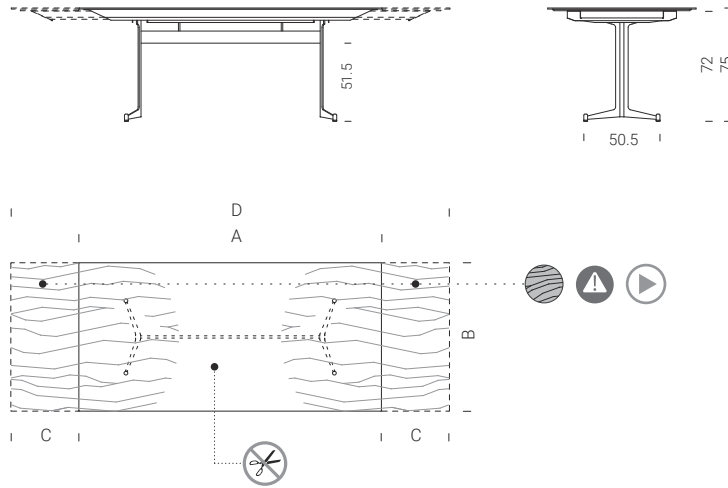

	A / D x B	C		S05 S06 S07 S08	L03 L06	L08 L10 L11	Y36 Y34 Y37 Y39 Y40
ETAV0963	170 / 260 x 90	45+45	6 (10)	4175	3695	3954	4195
ETAV0966	170 / 260 x 98	45+45	6 (10)	4262	3772	4036	4282
ETAV0964	200 / 290 x 90	45+45	8 (12)	4420	3912	4186	4441
ETAV0967	200 / 290 x 98	45+45	8 (12)	4531	4011	4291	4553
ETAV0965	230 / 320 x 90	45+45	10 (12)	4773	4225	4521	4796
ETAV0968	230 / 320 x 98	45+45	10 (12)	4891	4329	4632	4914

le allunghe possono essere posizionate all'interno del tavolo.
the extensions can be positioned inside the table.
les rallonges peuvent  tre plac es   l'int rieur de la table.
die Verl ngerungen k nnen innerhalb des Tisches gelegt werden.
las extensiones pueden colocarse dentro de la mesa.

TAVOLI DOGATI / SLATTED TABLES / TABLES   LATTES DAUBEN-TISCHE / MESAS LAMINADAS

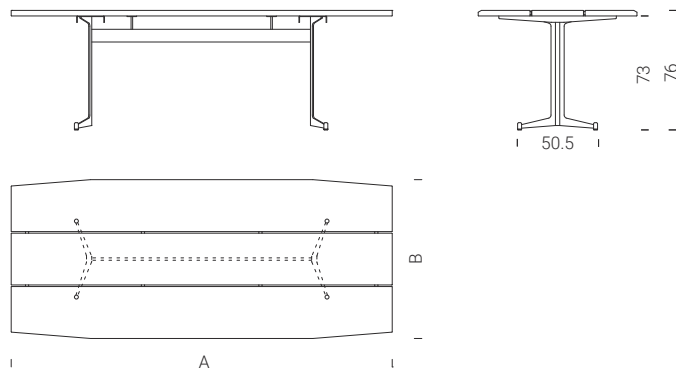

	A x B		T01 T03	T02 T05	
ETAV0958	180 x 100	6	3491	3834	3666
ETAV0961	240 x 100	10	4138	4930	4410
ETAV0962	300 x 100	12	5198	5742	5470



impiallacciatura continua su top e allunghe
continues veneer on top and extensions
les veines du placage bois suivent sur les rallonges
sauberer Furnierverlauf  ber Tisch- und Verl ngerungsplatte
chapa de madera contin a en el plano y extensiones



top e allunghe nella stessa finitura
top and extensions with the same finish
plateau et rallonges dans la m me finition
Abdeck- und Ausziehplatten in derselben Vollendung
Encimera y extensiones en el mismo acabado



Apertura allunghe
Opening of extensions
Ouverture de rallonges
 ffnung verl ngerungsst cke
Apertura de la extensi n



esterno **T04**
outdoor **T04**
ext rieur **T04**
drau en **T04**
exterior **T04**



disponibili riduzioni a misura
tailor-made reduction available
disponibles r ductions sur mesure
Verkleinerung nach Kundenwunsch
disponibles reducciones a medida

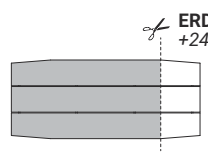



acciaio verniciato/painted steel/acier peint
lackierter Stahl/acero pintado

- C12** bianco/white
- C21** seta/silk
- C23** corda/ecru
- C30** ghisa/cast-iron
- C14** antracite/anthracite
- C08** nero/black
- C18** verde/green
- C26** corten/corten
- C29** bronzo/bronze
- C37** rame/copper
- C38** titanio/titanium



legno massiccio/solid wood
bois massif/Massivholz
madera maciza

- T01** rovere/oak
- T02** noce/walnut
- T03** iroko
- T04** iroko outdoor
- T05** rovere nero/black oak



ceramica/ceramic/c eramique
Keramik/cer mico

- S05** antracite/anthracite
- S06** nero/black
- S07** porfido/porfido
- S08** cardoso/cardoso



HPL POLARIS®

- L03** bianco/white
- L10** grigio chiaro/light grey
- L11** grigio scuro/dark grey

HPL FENIX®

- L08** grigio Londra/London grey
- L06** nero/black



HPL+ cemento/concrete/ciment
zement/cemento

- D01** bianco calce/lime white
- D02** grigio Portland/Portland grey
- D03** nero/black

HPL+ metallo/metal/m tal/Metall/metal

- C31** ottone/brass
- C32** ottone scuro/dark brass
- C35** inox/inox
- C36** inox scuro/dark inox



HPL+ legno/wood/bois/Holz/madera

- Y36** rovere/oak
- Y34** noce/walnut
- Y37** rovere affumicato/smoked oak
- Y39** frassino nero/black ash
- Y40** frassino argilla/clay ash

HPL+ ecotouch

- N01** sabbia/sand
- N02** basalto/basalt

TAVOLI RETTANGOLARI / RECTANGULAR TABLES / TABLES RECTANGULAIRES
RECHTECKIGE TISCHE / MESAS RECTANGULARES

T9

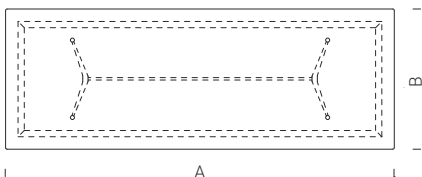
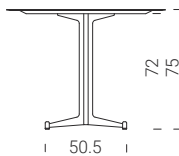
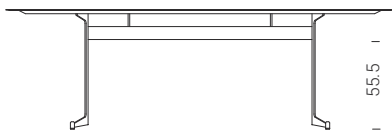

	A x B		T01 T03 T04	T02 T05	S05 S06	S07 S08	L03 L06	L08 L10 L11	D01 D02 D03	C31 C32 C35 C36	Y36 Y34 Y37 Y39 Y40	N01 N02		
ETAV0901	120 x 78	4	1605	1740	1671	1671	1464	1541	1698	2146	1677	1574	971	+175
ETAV0902	160 x 78	6	2037	2091	1871	1871	1642	1739	1908	2509	1887	1742	1089	+175
ETAV0903	180 x 78	8	2172	2241	2011	2011	1746	1852	2027	2698	2007	1841	1158	+175
ETAV0904	200 x 78	8	2301	2425	2172	2172	1885	2012	2201	2943	2180	1996	1208	+272
ETAV0905	120 x 90	6	1850	1876	1718	1718	1500	1585	1741	2257	1722	1598	995	+175
ETAV0906	160 x 90	6	2166	2248	2023	2023	1760	1869	2045	2729	2025	1854	1167	+175
ETAV0907	180 x 90	8	2319	2421	2209	2209	1958	2077	2233	3001	2225	2018	1300	+175
ETAV0908	200 x 90	8	2484	2624	2336	2336	2019	2161	2359	3202	2338	2122	1340	+272
ETAV0909	220 x 90	8	2674	2828	2460	2460	2153	2307	2515	3720	2495	2252	1380	+272
ETAV0910	240 x 90	10	2871	3280	2739	2739	2371	2537	2766	4071	2744	2480	1520	+272
ETAV0911	180 x 98	8	2429	2557	2263	2263	1967	2095	2286	3119	2267	2051	1304	+175
ETAV0912	200 x 98	8	2500	2783	2450	2450	2120	2271	2476	3391	2456	2218	1359	+272
ETAV0913	220 x 98	8	2682	2994	2601	2601	2270	2435	2651	3958	2631	2365	1455	+272
ETAV0914	240 x 98	10	2879	3287	2882	2882	2499	2677	2915	4331	2893	2603	1602	+272
ETAV0915	300 x 98	12	3616	3828	3371	3371	2953	3166	3442	5204	3418	3054	1893	+272
ETAV0916	200 x 110	8	2750	3061	2695	2695	2332	2498	2724	3730	2702	2440	1495	+272
ETAV0917	220 x 110	8	2950	3293	2862	2862	2497	2679	2916	4354	2894	2601	1601	+272
ETAV0918	240 x 110	10	3120	3494	3170	3170	2749	2945	3207	4764	3182	2863	1762	+272
ETAV0919	300 x 110	8	3977	4211	3708	3708	3248	3483	3786	5724	3760	3359	2082	+272



maggiorazione per esterno riparato solo per
surcharge for sheltered outdoor only for
majoration pour ext rieur prot g  juste pour
Zuschlag f r drau en gesch tzt nur f r
aumento para exterior reparado solo para

T04 S05 D01 L03 L08 C35
S06 D02 L06 L10 C36
S07 D03 L11
S08



solo telaio (info pg.100)
frame only (info on pg.100)
seulement b ti (info pg.100)
Ausschlie lich Rahmen (Info pg.100)
solo marco (informaci n pg.100)



accessori disponibili a pg.174
accessories available on pg.174
accessoires disponibles pg. 174
erh ltliches Zubeh r auf pg.174
accesorios disponibles en pg.174



disponibili riduzioni a misura
tailor-made reduction available
disponibles r ductions sur mesure
Verkleinerung nach Kundenwunsch
disponibles reducciones a medida

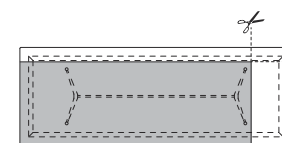

ERDT0901
+240  

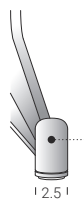

acciaio verniciato/painted steel/acier peint
lackierter Stahl/acero pintado

- C12** bianco/white
- C21** seta/silk
- C23** corda/ecru
- C30** ghisa/cast-iron
- C14** antracite/anthracite
- C08** nero/black
- C18** verde/green
- C26** corten/corten
- C29** bronzo/bronze
- C37** rame/copper
- C38** titanio/titanium



legno massiccio/solid wood
bois massif/Massivholz
madera maciza

- T01** rovere/oak
- T02** noce/walnut
- T03** iroko
- T04** iroko outdoor
- T05** rovere nero/black oak



ceramica/ceramic/c eramique
Keramik/cer mico

- S05** antracite/anthracite
- S06** nero/black
- S07** porfido/porfido
- S08** cardoso/cardoso



HPL POLARIS®

- L03** bianco/white
 - L10** grigio chiaro/light grey
 - L11** grigio scuro/dark grey
- HPL FENIX®
- L08** grigio Londra/London grey
 - L06** nero/black



HPL+ cemento/concrete/ciment
zement/cemento

- D01** bianco calce/lime white
- D02** grigio Portland/Portland grey
- D03** nero/black

HPL+ metallo/metal/m tal/Metall/metal

- C31** ottone/brass
- C32** ottone scuro/dark brass
- C35** inox/inox
- C36** inox scuro/dark inox



HPL+ legno/wood/bois/Holz/madera

- Y36** rovere/oak
- Y34** noce/walnut
- Y37** rovere affumicato/smoked oak
- Y39** frassino nero/black ash
- Y40** frassino argilla/clay ash

HPL+ ecotouch

- N01** sabbia/sand
- N02** basalto/basalt

TAVOLI A TESTA TONDA / ROUND HEAD TABLES / TABLES AUX EXTR MIT S ARRONDIES
RUNDER KOPF TISCHE / MESAS REDONDAS DE ESTRUCTURA LINEAL

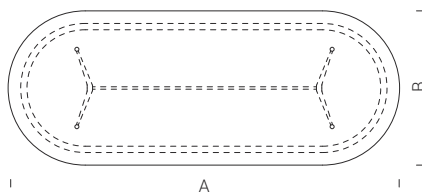
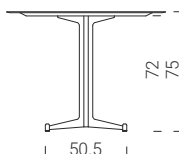

	A x B		T01 T03 T04	T02 T05	S05 S06	S07 S08	L03 L06	L08 L10 L11	D01 D02 D03	C31 C32 C35 C36	Y36 Y34 Y37 Y39 Y40	N01 N02		
ETAV0922	180 x 78	8	2172	2241	2011	2011	1746	1852	2027	2698	2007	1841	1158	+175
ETAV0923	200 x 78	8	2301	2425	2172	2172	1885	2012	2201	2943	2180	1996	1208	+272
ETAV0924	180 x 90	8	2319	2421	2209	2209	1958	2077	2233	3001	2225	2018	1300	+175
ETAV0925	200 x 90	8	2484	2624	2336	2336	2019	2161	2359	3202	2338	2122	1340	+272
ETAV0926	220 x 90	8	2674	2828	2460	2460	2153	2307	2515	3720	2495	2252	1380	+272
ETAV0927	240 x 90	10	2871	3280	2739	2739	2371	2537	2766	4071	2744	2480	1520	+272
ETAV0928	180 x 98	8	2429	2557	2263	2263	1967	2095	2286	3119	2267	2051	1304	+175
ETAV0929	200 x 98	8	2500	2783	2450	2450	2120	2271	2476	3391	2456	2218	1359	+272
ETAV0930	220 x 98	8	2682	2994	2601	2601	2270	2435	2651	3958	2631	2365	1455	+272
ETAV0931	240 x 98	10	2879	3287	2882	2882	2499	2677	2915	4331	2893	2603	1602	+272
ETAV0932	300 x 98	12	3616	3828	3371	3371	2953	3166	3442	5204	3418	3054	1893	+272

TAVOLI A BOTTE / BARREL VAULT TABLES / TABLES TONNEAU
WEINFASS-TISCHE / MESAS DE BARRIL

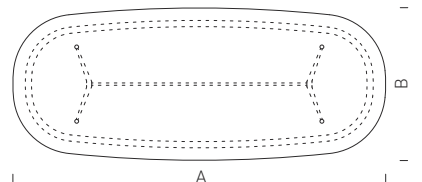
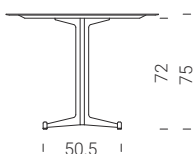

	A x B		T01 T03 T04	T02 T05	S05 S06	S07 S08	L03 L06	L08 L10 L11	D01 D02 D03	C31 C32 C35 C36	Y36 Y34 Y37 Y39 Y40	N01 N02		
ETAV0933	180 x 98	8	2429	2557	2263	2263	1967	2095	2286	3119	2267	2051	1304	+175
ETAV0934	200 x 98	8	2500	2783	2450	2450	2120	2271	2476	3391	2456	2218	1359	+272
ETAV0935	220 x 98	8	2682	2994	2601	2601	2270	2435	2651	3958	2631	2365	1455	+272
ETAV0936	240 x 98	10	2879	3287	2882	2882	2499	2677	2915	4331	2893	2603	1602	+272
ETAV0937	300 x 98	12	3616	3828	3371	3371	2953	3166	3442	5204	3418	3054	1893	+272
ETAV0938	180 x 105	8	2623	2761	2444	2444	2124	2262	2468	3368	2448	2215	1408	+175
ETAV0939	200 x 105	8	2750	3061	2695	2695	2332	2498	2724	3730	2702	2440	1495	+272
ETAV0940	220 x 105	8	2950	3293	2862	2862	2497	2679	2916	4354	2894	2601	1601	+272
ETAV0941	240 x 105	10	3120	3494	3170	3170	2749	2945	3207	4764	3182	2863	1762	+272
ETAV0942	300 x 105	12	3977	4211	3708	3708	3248	3483	3786	5724	3760	3359	2082	+272

maggiorazione per esterno riparato
surcharge for sheltered outdoor
majoration pour ext rieur prot g 
Zuschlag f r drau en gesch tzt
aumento para exterior reparado

- T04** **P01** **L03** **L08** **C35**
- D01** **L06** **L10** **C36**
- D02** **L11**
- D03** **L12**

solo telaio (info pg.100)
frame only (info on pg.100)
seulement b ti (info pg.100)
Ausschlie lich Rahmen (Info pg.100)
solo marco (informaci n pg.100)

accessori disponibili a pg.174
accessories available on pg.174
accessoires disponibles pg. 174
erh ltliches Zubeh r auf pg.174
accesorios disponibles en pg.174

disponibili riduzioni a misura
tailor-made reduction available
disponibles r ductions sur mesure
Verkleinerung nach Kundenwunsch
disponibles reducciones a medida

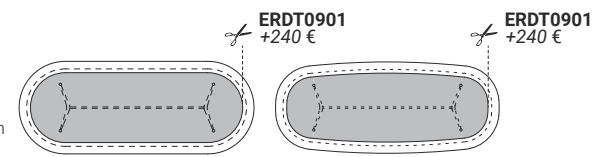



acciaio verniciato/painted steel/acier peint
lackierter Stahl/acero pintado

- C12** bianco/white
- C21** seta/silk
- C23** corda/ecru
- C30** ghisa/cast-iron
- C14** antracite/anthracite
- C08** nero/black
- C18** verde/green
- C26** corten/corten
- C29** bronzo/bronze
- C37** rame/copper
- C38** titanio/titanium



legno massiccio/solid wood
bois massif/Massivholz
madera maciza

- T01** rovere/oak
- T02** noce/walnut
- T03** iroko
- T04** iroko outdoor
- T05** rovere nero/black oak



ceramica/ceramic/c eramique
Keramik/cer mico

- S05** antracite/anthracite
- S06** nero/black
- S07** porfido/porfido
- S08** cardoso/cardoso



HPL POLARIS®

- L03** bianco/white
- L10** grigio chiaro/light grey
- L11** grigio scuro/dark grey

HPL FENIX®

- L08** grigio Londra/London grey
- L06** nero/black



HPL+ cemento/concrete/ciment
zement/cemento

- D01** bianco calce/lime white
- D02** grigio Portland/Portland grey
- D03** nero/black

HPL+ metallo/metal/m tal/Metall/metal

- C31** ottone/brass
- C32** ottone scuro/dark brass
- C35** inox/inox
- C36** inox scuro/dark inox



HPL+ legno/wood/bois/Holz/madera

- Y36** rovere/oak
- Y34** noce/walnut
- Y37** rovere affumicato/smoked oak
- Y39** frassino nero/black ash
- Y40** frassino argilla/clay ash

HPL+ ecotouch

- N01** sabbia/sand
- N02** basalto/basalt

TAVOLI OVALI / OVAL TABLES / TABLES OVALES OVALTISCHE / MESAS OVALADAS

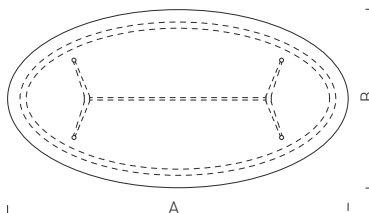
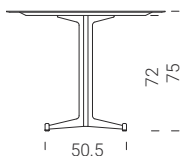
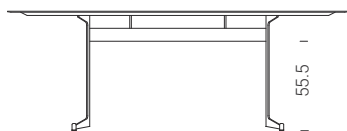

	A x B		T01 T03 T04	T02 T05	S05 S06	S07 S08	L03 L06	L08 L10 L11	D01 D02 D03	C31 C32 C35 C36	Y36 Y34 Y37 Y39 Y40	N01 N02		
ETAV0945	160 x 85	6	2073	2157	1984	1984	1663	1766	1932	2566	1914	1752	1066	+175
ETAV0946	180 x 95	8	2393	2499	2254	2254	1898	2023	2146	3006	2189	1980	1216	+175
ETAV0947	200 x 105	8	2677	2980	2581	2581	2167	2329	2534	3794	2515	2255	1389	+272
ETAV0948	220 x 115	8	3059	3425	2936	2936	2473	2661	2887	4399	2870	2551	1585	+272
ETAV0949	248 x 128	10	3233	3712	3156	-	2983	3213	-	-	3462	3059	1913	+272

SCRITTOI / WRITING DESKS / SECR TAIRES SCHREIBTISCHEN / ESCRITORIOS

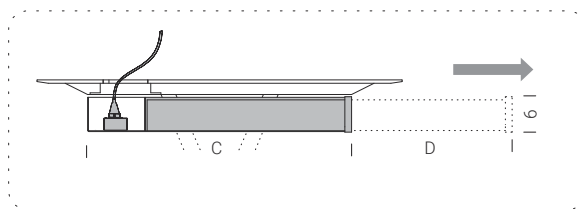
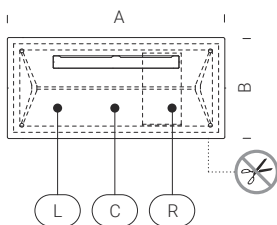
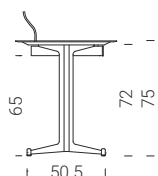
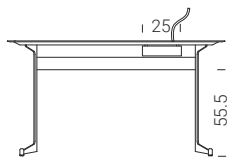

	A x B	(C) (D)	S05 S06	S07 S08	L03 L06	L08 L10 L11	D01 D02 D03	C31 C32 C35 C36	Y36 Y34 Y37 Y39 Y40	N01 N02
ETAV0953	100 x 65	(47) (28)	1814	1814	1560	1618	1801	2188	1772	1710
ETAV0954	120 x 65	(47) (28)	2049	2049	1813	1920	1980	2422	1948	1868
ETAV0955	140 x 65	(47) (28)	2224	2224	1849	1932	2146	2662	2113	2015
ETAV0956	160 x 65	(47) (28)	2351	2351	1956	2050	2273	2853	2240	2125
ETAV0957	160 x 78	(53) (34)	2513	2513	2094	2206	2439	3115	2406	2264



ordinabile in posizione C (centrale).
available in the following positions: C (central).
peut  tre command  en position C (centrale).
aufstellbar in Position C (Mitte).
disponible en posici n C (central).



ordinabile in posizione L (sinistra), C (centrale), R (destra).
available in the following positions: L (left), C (central), R (right).
peut  tre command  en position L (gauche), C (centrale), R (droite).
aufstellbar in Position L (links), C (Mitte), R (rechts).
disponible en posici n L (izquierda), C (central), R (derecha).

cassetto in acciaio e frontale nelle finiture del tavolo.
steel drawer and front in the table finishings.
 tiroir en acier et fa ade dans les m mes finitions que la table.
Stahlschublade und Vorderseite in den Tischausf hrungen.
caj n de acero y frontal en los acabados de la mesa.



maggiorazione per esterno riparato solo per
surcharge for sheltered outdoor only for
majoration pour ext rieur prot g  juste pour
Zuschlag f r drau en gesch tzt nur f r
aumento para exterior reparado solo para

T04 S05 D01 L03 L08 C35
S06 D02 L06 L10 C36
S07 D03 L11
S08



solo telaio (info pg.100)
frame only (info on pg.100)
accessoires disponibles pg. 174
Ausschlie lich Rahmen (Info pg.100)
solo marco (informaci n pg.100)



accessori disponibili a pg.174
accessories available on pg.174
accessoires disponibles pg. 174
erh ltliches Zubeh r auf pg.174
accesorios disponibles en pg.174



disponibili riduzioni a misura
tailor-made reduction available
disponibles r ductions sur mesure
Verkleinerung nach Kundenwunsch
disponibles reducciones a medida

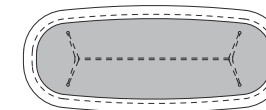

ERDT0901
+240  

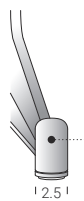

acciaio verniciato/painted steel/acier peint
lackierter Stahl/acero pintado

- C12** bianco/white
- C21** seta/silk
- C23** corda/ecru
- C30** ghisa/cast-iron
- C14** antracite/anthracite
- C08** nero/black
- C18** verde/green
- C26** corten/corten
- C29** bronzo/bronze
- C37** rame/copper
- C38** titanio/titanium

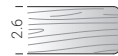

legno massiccio/solid wood
bois massif/Massivholz
madera maciza

- T01** rovere/oak
- T02** noce/walnut
- T03** iroko
- T04** iroko outdoor
- T05** rovere nero/black oak



ceramica/ceramic/c eramique
Keramik/cer amico

- S05** antracite/anthracite
- S06** nero/black
- S07** porfido/porfido
- S08** cardoso/cardoso



HPL POLARIS®

- L03** bianco/white
- L10** grigio chiaro/light grey
- L11** grigio scuro/dark grey

HPL FENIX®

- L08** grigio Londra/London grey
- L06** nero/black



HPL+ cemento/concrete/ciment
zement/cemento

- D01** bianco calce/lime white
- D02** grigio Portland/Portland grey
- D03** nero/black

HPL+ metallo/metal/m etal/Metall/metal

- C31** ottone/brass
- C32** ottone scuro/dark brass
- C35** inox/inox
- C36** inox scuro/dark inox



HPL+ legno/wood/bois/Holz/madera

- Y36** rovere/oak
- Y34** noce/walnut
- Y37** rovere affumicato/smoked oak
- Y39** frassino nero/black ash
- Y40** frassino argilla/clay ash

HPL+ ecotouch

- N01** sabbia/sand
- N02** basalto/basalt

TAVOLI TONDI / ROUND TABLES / TABLES RONDES RUNDTISCHE TISCHE / MESAS REDONDAS

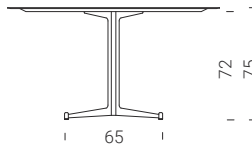
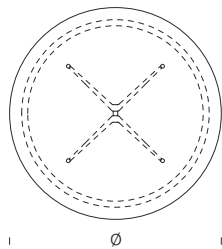

	Ø		T01 T03 T04	T02 T05	S05 S06	S07 S08	L03 L06	L08 L10 L11	D01 D02 D03	C31 C32 C35 C36	Y36 Y34 Y37 Y39 Y40	N01 N02		
ETAV0950	128	6	2275	2512	2156	-	1875	2008	-	-	2174	1975	1202	+175
ETAV0951	140	7	2694	2824	2359	-	2051	2182	-	-	2356	2113	1315	+272
ETAV0952	160	8	2948	3185	2766	-	2407	2566	-	-	2764	2440	1543	+272

TAVOLI QUADRATI A BOTTE / SQUARE BARREL TABLES / TABLES   TONNEAU CARR ES VIERECKIGE TONNENF ORMIGE TISCHE / MESAS CUADRADAS

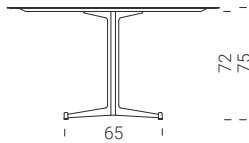
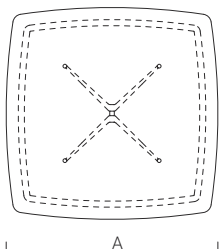

	A x B		T01 T03 T04	T02 T05	S05 S06	S07 S08	L03 L06	L08 L10 L11	D01 D02 D03	C31 C32 C35 C36	Y36 Y34 Y37 Y39 Y40	N01 N02		
ETAV0943	120 x 120	6	2326	2449	2170	2170	1883	2007	2188	2987	2171	1964	1384	+175
ETAV0944	140 x 140	8	2619	2767	2448	-	2130	2320	-	-	2505	2225	1462	+272

TAVOLI QUADRATI / SQUARE TABLES / TABLES CARR ES / QUADRATISCHE TISCHE / MESAS CUADRADAS

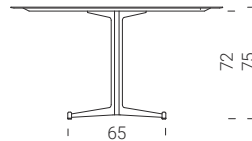
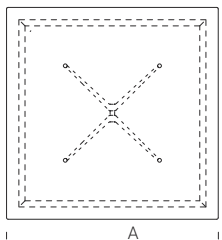

	A x B		T01 T03 T04	T02 T05	S05 S06	S07 S08	L03 L06	L08 L10 L11	D01 D02 D03	C31 C32 C35 C36	Y36 Y34 Y37 Y39 Y40	N01 N02		
ETAV0920	120 x 120	6	2326	2449	2170	2170	1883	2007	2188	2987	2171	1964	1384	+175
ETAV0921	140 x 140	8	2619	2767	2448	-	2130	2320	-	-	2505	2225	1462	+272



maggiorazione per esterno riparato solo per surcharge for sheltered outdoor only for majoration pour ext rieur prot g  juste pour Zuschlag f r drau en gesch tzt nur f r aumento para exterior reparado solo para

T04 S05 D01 L03 L08 C35
S06 D02 L06 L10 C36
S07 D03 L11
S08



solo telaio (info pg.100)
frame only (info on pg.100)
seulement b ti (info pg.100)
Ausschlie lich Rahmen (Info pg.100)
solo marco (informaci n pg.100)



accessori disponibili a pg.174
accessories available on pg.174
accessoires disponibles pg. 174
erh ltliches Zubeh r auf pg.174
accesorios disponibles en pg.174



disponibili riduzioni a misura
tailor-made reduction available
disponibles r ductions sur mesure
Verkleinerung nach Kundenwunsch
disponibles reducciones a medida

ERDT0901
+240  

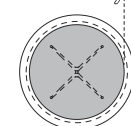

ERDT0901
+240  

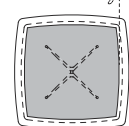

ERDT0901
+240  

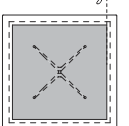

PASSACAVO / CABLE GLAND / PASSE-CÂBLE / KABELDURCHLASS / PASACABLES

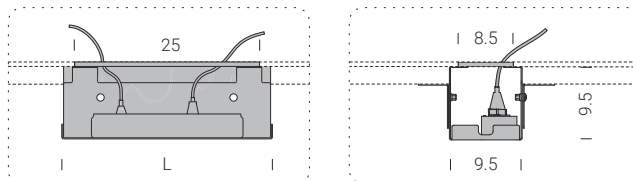
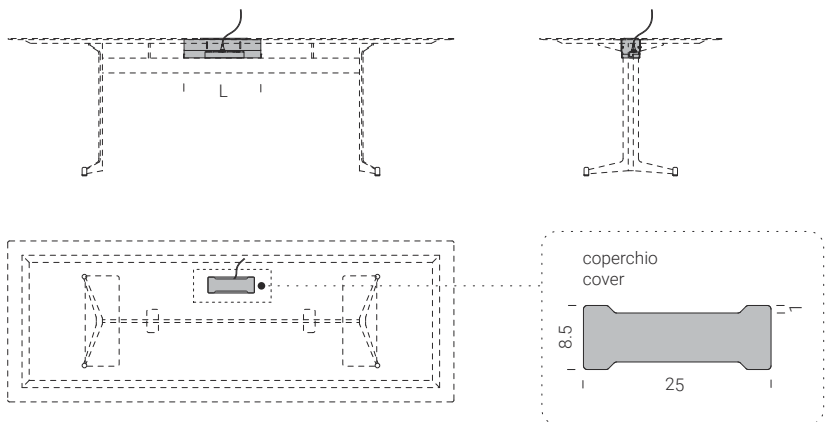

cesto in acciaio e copertura magnetica nelle finiture del tavolo.
steel basket and magnetic cover in the table finishings.
panier en acier et couvercle magnétique dans les mêmes finitions que la table.
Stahlkorb und Magnetabdeckung in der Tischausführung.
cesto de acero y cubierta magnética en los acabados de la mesa.

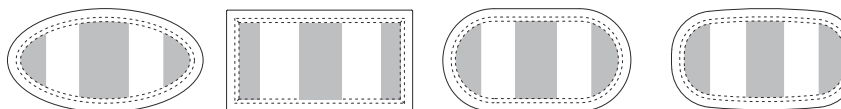

Il passacavi può essere posizionato esclusivamente nelle aree evidenziate.
the cable tidy can be placed only in the highlighted areas
le passe-câbles peut être placé que dans le domaines mis en évidence
das Kabeldurchführung kann nur in den hervorgehobenen Bereichen angeordnet werden
el pasacables se puede colocar sólo en las áreas resaltadas

	L	
SACC0003	28	185
SACC0004	40	205

vedi catalogo a pg.156
refer to catalogue pg.156
Voir catalogue pg. 156
siehe Katalog auf pg.156
véase pg.156 del catálogo

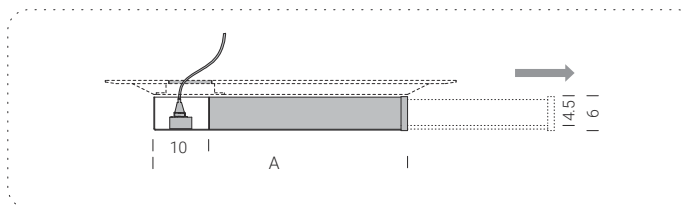
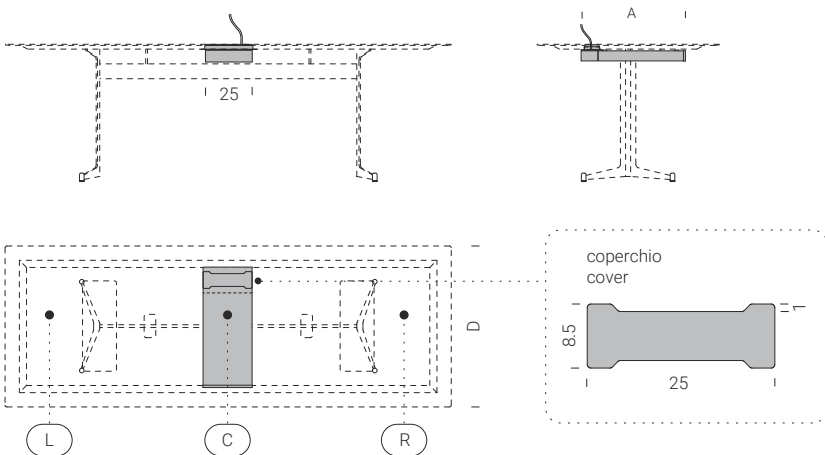
CASSETTO CON PASSACAVO / DRAWER WITH CABLE GLAND / TIROIR AVEC PASSE-CÂBLE
SCHUBLADE MIT KABELDURCHLASS / CAJÓN CON PASACABLES

cassetto in acciaio e frontale nelle finiture del tavolo. (il prezzo include la foratura del top tavolo).
steel drawer and front in the table finishings. (the price includes perforation of the table top).
 tiroir en acier et façade dans les mêmes finitions que la table. (le prix inclut le perçage du plateau de la table).
Stahlschublade und Vorderseite in den Tischausführungen. (Die Bohrung der Tischplatte ist im Preis inbegriffen).
cajón de acero y frontal en los acabados de la mesa. (el precio incluye el perforado de la encimera).

ordinabile in posizione L (sinistra), R (destra), C (centrale).
available in the following positions: L (left), R (right), C (central).
peut être commandé en position L (gauche), R (droite), C (centrale).
aufstellbar in Position L (links), R (rechts), C (Mitte).
disponible en posición L (izquierda), R (derecha), C (central).

	A x B x C (D)	
GACC0001	47 x 25 x 6 (65)	260
GACC0002	53 x 25 x 6 (78)	280
GACC0003	68 x 25 x 6 (90)	320

vedi catalogo a pg.200 / refer to catalogue pg.200
Voir catalogue pg.200 / siehe Katalog auf pg.200
véase pg.200 del catálogo



ceramica/ceramic/c eramique
Keramik/cer amico

S05 antracite/anthracite
S06 nero/black
S07 porfido/porfido
S08 cardoso/cardoso



HPL POLARIS®

L03 bianco/white
L10 grigio chiaro/light grey
L11 grigio scuro/dark grey

HPL FENIX®

L08 grigio Londra/London grey
L06 nero/black



HPL+ cemento/concrete/ciment
zement/cemento

D01 bianco calce/lime white
D02 grigio Portland/Portland grey
D03 nero/black

HPL+ metallo/metal/m etal/Metall/metal

C31 ottone/brass
C32 ottone scuro/dark brass
C35 inox/inox
C36 inox scuro/dark inox

CASSETTO / DRAWER / TIROIR / SCHUBLADE / CAJ N

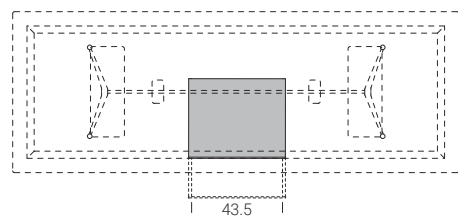
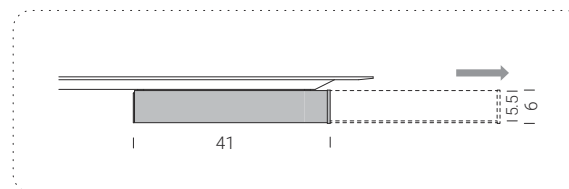
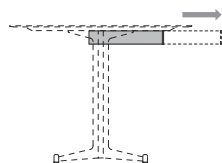
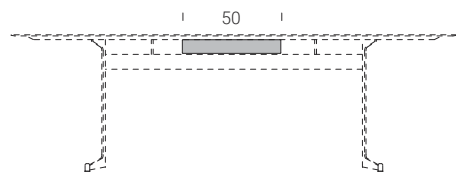

A x B x C

SACC0006	50 x 41 x 6	368
-----------------	-------------	-----

vedi catalogo a pg.206
refer to catalogue pg.206
Voir catalogue pg.206
siehe Katalog auf pg.206
v ase pg.206 del cat logo

scocca in acciaio e frontale nelle finiture del tavolo.
Steel body and front in the table finishings.
coque en acier et fa ade dans les m emes finitions que la table.
Stahlaufbau und Vorderseite in den Tischausf hrungen.
chapa de acero y frontal en los acabados de la mesa.



disponibile per tavoli a partire da lunghezza 220 cm
available for tables at least 220 cm long
disponible pour des tables   partir d'une longueur de 220 cm
Erh ltlich f r Tische ab einer Tischl nge von 220 cm
disponible para mesas desde 220 cm de longitud

VASSOI / TRAYS / PLATEAUX / TABLETS / BANDEJAS

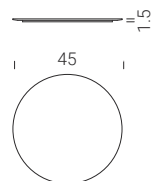

S05			L08	D01	C31
S06			L10	D02	C32
S07	L03		L11	D03	C35
S08	L06				C36

SACC0007	45 x 1.5	190	165	180	205	245
-----------------	----------	-----	-----	-----	-----	-----

vedi catalogo a pg.172 / refer to catalogue pg.172
Voir catalogue pg. 172 / siehe Katalog auf pg.172
v ase pg.172 del cat logo

T10



LA RICERCA DI JEAN PROUVÉ CON IL TAVOLO TRAPÈZE DEL 1950/54 HA INSPIRATO IL DESIGN DEL TAVOLO T10. I TERMINALI IN OTTONE O OTTONE BRUNITO PROTEGGONO IL BASAMENTO DA URTI ACCIDENTALI E GARANTISCONO STABILITÀ AL TAVOLO. T10, IN VERSIONE FISSA, È CONFIGURABILE CON 5 GEOMETRIE DI TOP DISPONIBILI IN 8 CATEGORIE DI FINITURE, MENTRE PER I BASAMENTI LA SCELTA È TRA 11 COLORAZIONI A POLVERI.

The research of Jean Prouvé with the 1950/54 Trapèze table has inspired the design of the T10 table. The brass or burnished brass ends protect the base against accidental impacts and guarantee the stability of the table. T10, in the fixed version, can have 5 geometries of top available in 8 types of finish, while for the bases there is a choice of 11 powder coated colours.

Les recherches de Jean Prouvé avec la table Trapèze de 1950/54 ont inspiré le design de la table T10. Les extrémités en laiton ou en laiton bruni protègent le socle contre les chocs accidentels et garantissent la stabilité de la table. T10, dans sa version fixe, peut être configurée en choisissant parmi 5 formes de plateau, disponibles en 8 catégories de finitions, tandis que 11 couleurs de poudre sont disponibles pour les socles.

Die Studien von Jean Prouvé mit dem Tisch Trapèze von 1950/54 haben das Design des Tisches T10 inspiriert. Die Endteile aus Messing und brüniertem Messing schützen das Untergestell vor Stößen und verleihen dem Tisch Stabilität. T10, in fester Version, kann mit 5 Tischplattenformen, verfügbar in 8 Beschichtungskategorien, konfiguriert werden, während für das Untergestell zwischen 11 Pulverfärbungen gewählt werden kann.

Las investigaciones de Jean Prouvé con la mesa Trapèze de 1950/54 inspiraron el diseño de la mesa T10. Los remates de latón o latón bruñido protegen la base de golpes accidentales y proporcionan estabilidad a la mesa. La versión fija de T10 puede configurarse con 5 geometrías de tablero disponibles en 8 categorías de acabados, mientras que la base está disponible en 11 colores con recubrimiento pulverizado.



Disponibili riduzioni a misura
Custom reductions available
Réductions sur mesure disponibles
Verkürzungen auf Maß erhältlich
Disponibles reducciones a medida



Passacavo disponibile per tutti i top
Cable gland available for all tops
Passe-câble disponible pour tous les plateaux
Kabeldurchlass für alle Abschlussborde verfügbar
Pasacables disponible para todos los sobres



Piedini regolabili in acciaio inox.
Adjustable feet in stainless steel.
Pieds réglables en acier inox.
Regulierbaren Edelstahlfüßchen.
Patas regulables de acero inoxidable

- acciaio verniciato/painted steel/acier peint
lackierter Stahl/acero pintado
- C12** bianco/white
 - C21** seta/silk
 - C23** corda/ecru
 - C30** ghisa/cast-iron
 - C14** antracite/anthracite
 - C08** nero/black
 - C18** verde/green
 - C26** corten/corten
 - C29** bronzo/bronze
 - C37** rame/copper
 - C38** titanio/titanium

- legno massiccio/solid wood
bois massif/Massivholz
madera maciza
- T01** rovere/oak
 - T02** noce/walnut
 - T03** iroko
 - T04** iroko outdoor
 - T05** rovere nero/black oak



- ceramica/ceramic/c eramique
Keramik/cer amico
- S05** antracite/anthracite
 - S06** nero/black
 - S07** porfido/porfido
 - S08** cardoso/cardoso

- HPL POLARIS®
- L03** bianco/white
 - L10** grigio chiaro/light grey
 - L11** grigio scuro/dark grey
- HPL FENIX®
- L08** grigio Londra/London grey
 - L06** nero/black

- HPL+ cemento/concrete/ciment
zement/cemento
- D01** bianco calce/lime white
 - D02** grigio Portland/Portland grey
 - D03** nero/black
- HPL+ metallo/metal/m etal/Metall/metal
- C31** ottone/brass
 - C32** ottone scuro/dark brass
 - C35** inox/inox
 - C36** inox scuro/dark inox

- HPL+ legno/wood/bois/Holz/madera
- Y36** rovere/oak
 - Y34** noce/walnut
 - Y37** rovere affumicato/smoked oak
 - Y39** frassino nero/black ash
 - Y40** frassino argilla/clay ash
- HPL+ ecotouch
- N01** sabbia/sand
 - N02** basalto/basalt

TAVOLI RETTANGOLARI / RECTANGULAR TABLES / TABLES RECTANGULAIRES RECHTECKIGE TISCHE / MESAS RECTANGULARES

	A x B		T01 T03 T04	T02 T05	S05 S06	S07 S08	L03 L06	L08 L10 L11	D01 D02 D03	C31 C32 C35 C36	Y36 Y34 Y37 Y39 Y40	N01 N02		
ETAV1001	120 x 78	4	2023	2194	2107	2107	1846	1943	2141	2705	2114	1984	1224	+220
ETAV1002	160 x 78	6	2568	2635	2359	2359	2070	2192	2405	3163	2379	2196	1373	+220
ETAV1003	180 x 78	8	2738	2826	2535	2535	2201	2334	2556	3401	2531	2321	1459	+220
ETAV1004	200 x 78	8	2900	3057	2738	2738	2376	2536	2775	3710	2748	2516	1523	+343
ETAV1005	120 x 90	6	2331	2365	2166	2166	1890	1998	2195	2845	2170	2014	1254	+220
ETAV1006	160 x 90	6	2731	2834	2550	2550	2219	2356	2578	3440	2553	2337	1471	+220
ETAV1007	180 x 90	8	2923	3052	2785	2785	2468	2619	2815	3783	2805	2544	1639	+220
ETAV1008	200 x 90	8	3131	3308	2944	2944	2545	2724	2973	4036	2947	2675	1689	+343
ETAV1009	220 x 90	8	3371	3565	3101	3101	2714	2908	3170	4689	3145	2839	1740	+343
ETAV1010	240 x 90	10	3619	4135	3452	3452	2989	3198	3487	5132	3459	3126	1916	+343
ETAV1011	180 x 98	8	3062	3223	2852	2852	2479	2641	2881	3932	2857	2586	1644	+220
ETAV1012	200 x 98	8	3152	3508	3088	3088	2672	2863	3122	4274	3096	2796	1713	+343
ETAV1013	220 x 98	8	3380	3774	3279	3279	2861	3070	3342	4990	3317	2981	1834	+343
ETAV1014	240 x 98	10	3629	4143	3633	3633	3150	3375	3675	5460	3647	3281	2019	+343
ETAV1015	300 x 98	12	4558	4825	4249	4249	3722	3992	4339	6560	4309	3850	2386	+343
ETAV1016	200 x 110	8	3467	3858	3397	3397	2939	3149	3434	4702	3406	3076	1884	+343
ETAV1017	220 x 110	8	3719	4151	3607	3607	3147	3377	3676	5489	3648	3279	2018	+343
ETAV1018	240 x 110	10	3933	4405	3996	3996	3465	3712	4043	6005	4012	3609	2221	+343
ETAV1019	300 x 110	8	5014	5308	4674	4674	4094	4391	4773	7216	4740	4235	2625	+343

 piedi disponibili in ottone **C31**, ottone scuro **C32** o verniciato a polveri nella finitura del telaio del tavolo.
feet available in **C31** brass, **C32** dark brass or painted steel in the finish of the table frame.

 maggiorazione per esterno riparato solo per surcharge for sheltered outdoor only for majoration pour ext erieur prot eg e juste pour Zuschlag f ur drau en gesch utzt nur f ur aumento para exterior reparado solo para

T04 S05 D01 L03 L08 C35
S06 D02 L06 L10 C36
S07 D03 L11
S08

 solo telaio (info pg.100)
frame only (info on pg.100)
seulement b ati (info pg.100)
Ausschlie lich Rahmen (Info pg.100)
solo marco (informaci n pg.100)

 accessori disponibili a pg.180
accessories available on pg.180
accessoires disponibles pg. 180
erh altliches Zubeh or auf pg.180
accesorios disponibles en pg.180

 disponibili riduzioni a misura
tailor-made reduction available
disponibles r eductions sur mesure
Verkleinerung nach Kundenwunsch
disponibles reducciones a medida

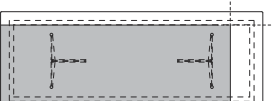
 **ERDT1001**
+240  

acciaio verniciato/painted steel/acier peint
lackierter Stahl/acero pintado

- C12** bianco/white
- C21** seta/silk
- C23** corda/ecru
- C30** ghisa/cast-iron
- C14** antracite/anthracite
- C08** nero/black
- C18** verde/green
- C26** corten/corten
- C29** bronzo/bronze
- C37** rame/copper
- C38** titanio/titanium



- legno massiccio/solid wood
bois massif/Massivholz
madera maciza
- T01** rovere/oak
 - T02** noce/walnut
 - T03** iroko
 - T04** iroko outdoor
 - T05** rovere nero/black oak



- ceramica/ceramic/c eramique
Keramik/cer mico
- S05** antracite/anthracite
 - S06** nero/black
 - S07** porfido/porfido
 - S08** cardoso/cardoso



- HPL POLARIS®
- L03** bianco/white
 - L10** grigio chiaro/light grey
 - L11** grigio scuro/dark grey
- HPL FENIX®
- L08** grigio Londra/London grey
 - L06** nero/black



- HPL+ cemento/concrete/ciment
zement/cemento
- D01** bianco calce/lime white
 - D02** grigio Portland/Portland grey
 - D03** nero/black
- HPL+ metallo/metal/m tal/Metall/metal
- C31** ottone/brass
 - C32** ottone scuro/dark brass
 - C35** inox/inox
 - C36** inox scuro/dark inox



- HPL+ legno/wood/bois/Holz/madera
- Y36** rovere/oak
 - Y34** noce/walnut
 - Y37** rovere affumicato/smoked oak
 - Y39** frassino nero/black ash
 - Y40** frassino argilla/clay ash
- HPL+ ecotouch
- N01** sabbia/sand
 - N02** basalto/basalt

**TAVOLI A TESTA TONDA / ROUND HEAD TABLES / TABLES AUX EXTR MIT S ARRONDIES
RUNDER KOPF TISCHE / MESAS REDONDAS DE ESTRUCTURA LINEAL**

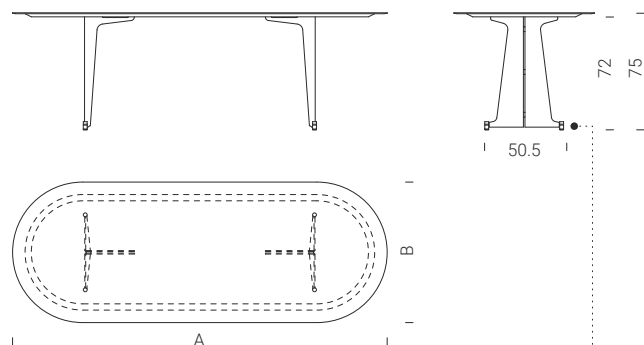

	A x B		T01 T03 T04	T02 T05	S05 S06	S07 S08	L03 L06	L08 L10 L11	D01 D02 D03	C31 C32 C35 C36	Y36 Y34 Y37 Y39 Y40	N01 N02		
ETAV1020	180 x 78	8	2738	2826	2535	2535	2201	2334	2556	3401	2531	2321	1459	+220
ETAV1021	200 x 78	8	2900	3057	2738	2738	2376	2536	2775	3710	2748	2516	1523	+343
ETAV1022	180 x 90	8	2923	3052	2785	2785	2468	2619	2815	3783	2805	2544	1639	+220
ETAV1023	200 x 90	8	3131	3308	2944	2944	2545	2724	2973	4036	2947	2675	1689	+343
ETAV1024	220 x 90	8	3371	3565	3101	3101	2714	2908	3170	4689	3145	2839	1740	+343
ETAV1025	240 x 90	10	3619	4135	3452	3452	2989	3198	3487	5132	3459	3126	1916	+343
ETAV1026	180 x 98	8	3062	3223	2852	2852	2479	2641	2881	3932	2857	2586	1644	+220
ETAV1027	200 x 98	8	3152	3508	3088	3088	2672	2863	3122	4274	3096	2796	1713	+343
ETAV1028	220 x 98	8	3380	3774	3279	3279	2861	3070	3342	4990	3317	2981	1834	+343
ETAV1029	240 x 98	10	3629	4143	3633	3633	3150	3375	3675	5460	3647	3281	2019	+343
ETAV1030	300 x 98	12	4558	4825	4249	4249	3722	3992	4339	6560	4309	3850	2386	+343

piedi disponibili in ottone **C31**, ottone scuro **C32** o verniciato a polveri nella finitura del telaio del tavolo.
feet available in **C31** brass, **C32** dark brass or painted steel in the finish of the table frame.

**TAVOLI A BOTTE / BARREL VAULT TABLES / TABLES TONNEAU
WEINFASS-TISCHE / MESAS DE BARRIL**

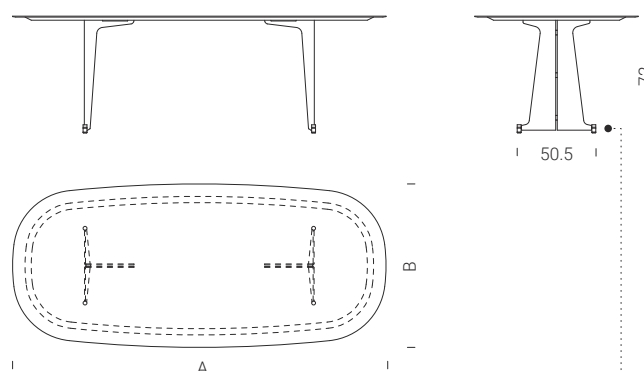

	A x B		T01 T03 T04	T02 T05	S05 S06	S07 S08	L03 L06	L08 L10 L11	D01 D02 D03	C31 C32 C35 C36	Y36 Y34 Y37 Y39 Y40	N01 N02		
ETAV1031	180 x 98	8	3062	3223	2852	2852	2479	2641	2881	3932	2857	2586	1644	+220
ETAV1032	200 x 98	8	3152	3508	3088	3088	2672	2863	3122	4274	3096	2796	1713	+343
ETAV1033	220 x 98	8	3380	3774	3279	3279	2861	3070	3342	4990	3317	2981	1834	+343
ETAV1034	240 x 98	10	3629	4143	3633	3633	3150	3375	3675	5460	3647	3281	2019	+343
ETAV1035	300 x 98	12	4558	4825	4249	4249	3722	3992	4339	6560	4309	3850	2386	+343
ETAV1036	180 x 105	8	3306	3480	3080	3080	2677	2852	3111	4246	3055	2792	1775	+220
ETAV1037	200 x 105	8	3467	3858	3397	3397	2939	3149	3434	4702	3406	3076	1884	+343
ETAV1038	220 x 105	8	3719	4151	3607	3607	3147	3377	3676	5489	3648	3279	2018	+343
ETAV1039	240 x 105	10	3933	4405	3996	3996	3465	3712	4043	6005	4012	3609	2221	+343
ETAV1040	300 x 105	12	5014	5308	4674	4674	4094	4391	4773	7216	4740	4235	2625	+343

piedi disponibili in ottone **C31**, ottone scuro **C32** o verniciato a polveri nella finitura del telaio del tavolo.
feet available in **C31** brass, **C32** dark brass or painted steel in the finish of the table frame.

maggiorazione per esterno riparato solo per surcharge for sheltered outdoor only for majoration pour ext rieur prot g  juste pour Zuschlag f r drau en gesch tzt nur f r aumento para exterior reparado solo para

- T04 S05 D01 L03 L08 C35**
S06 D02 L06 L10 C36
S07 D03 L11
S08

solo telaio (info pg.100)
frame only (info on pg.100)
seulement b ti (info pg.100)
Ausschlie lich Rahmen (Info pg.100)
solo marco (informaci n pg.100)

accessori disponibili a pg.180
accessories available on pg.180
accessoires disponibles pg. 180
erh ltliches Zubeh r auf pg.180
accesorios disponibles en pg.180

disponibili riduzioni a misura
tailor-made reduction available
disponibles r ductions sur mesure
Verkleinerung nach Kundenwunsch
disponibles reducciones a medida

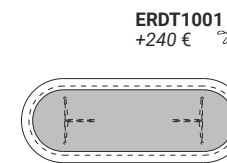

ERDT1001
+240  

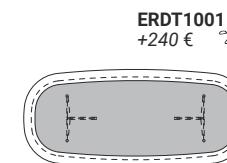

ERDT1001
+240  

acciaio verniciato/painted steel/acier peint
lackierter Stahl/acero pintado

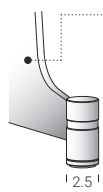

- C12** bianco/white
- C21** seta/silk
- C23** corda/ecru
- C30** ghisa/cast-iron
- C14** antracite/anthracite
- C08** nero/black
- C18** verde/green
- C26** corten/corten
- C29** bronzo/bronze
- C37** rame/copper
- C38** titanio/titanium



- legno massiccio/solid wood
bois massif/Massivholz
madera maciza
- T01** rovere/oak
 - T02** noce/walnut
 - T03** iroko
 - T04** iroko outdoor ☀️
 - T05** rovere nero/black oak



- ceramica/ceramic/c eramique
Keramik/cer mico
- S05** antracite/anthracite
 - S06** nero/black
 - S07** porfido/porfido
 - S08** cardoso/cardoso



- HPL POLARIS®
- L03** bianco/white
 - L10** grigio chiaro/light grey
 - L11** grigio scuro/dark grey
- HPL FENIX®
- L08** grigio Londra/London grey
 - L06** nero/black



- HPL+ cemento/concrete/ciment
zement/cemento
- D01** bianco calce/lime white
 - D02** grigio Portland/Portland grey
 - D03** nero/black
- HPL+ metallo/metal/m tal/Metall/metal
- C31** ottone/brass
 - C32** ottone scuro/dark brass
 - C35** inox/inox
 - C36** inox scuro/dark inox



- HPL+ legno/wood/bois/Holz/madera
- Y36** rovere/oak
 - Y34** noce/walnut
 - Y37** rovere affumicato/smoked oak
 - Y39** frassino nero/black ash
 - Y40** frassino argilla/clay ash
- HPL+ ecotouch
- N01** sabbia/sand
 - N02** basalto/basalt

TAVOLI OVALI / OVAL TABLES / TABLES OVALES OVALTISCHE / MESAS OVALADAS

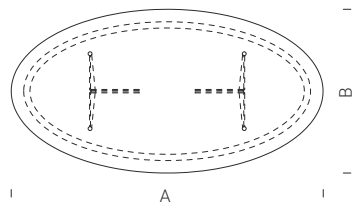
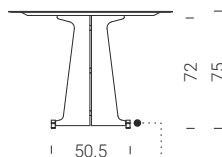
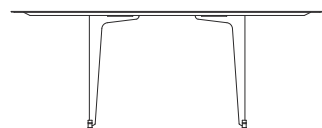

	A x B		T01 T03 T04	T02 T05	S05 S06	S07 S08	L03 L06	L08 L10 L11	D01 D02 D03	C31 C32 C35 C36	Y36 Y34 Y37 Y39 Y40	N01 N02		
ETAV1041	160 x 85	6	2613	2719	2502	2502	2096	2226	2436	3235	2412	2208	1344	+220
ETAV1042	180 x 95	8	3016	3150	2841	2841	2392	2551	2705	3789	2759	2495	1533	+220
ETAV1043	200 x 105	8	3374	3757	3253	3253	2732	2936	3194	4782	3171	2842	1751	+343
ETAV1044	220 x 115	8	3857	4318	3700	3700	3117	3355	3639	5545	3617	3215	1998	+343
ETAV1045	248 x 128	10	4076	4679	3978	-	3761	4050	-	-	4364	3855	2411	+343

piedi disponibili in ottone **C31**, ottone scuro **C32** o verniciato a polveri nella finitura del telaio del tavolo.
 feet available in **C31** brass, **C32** dark brass or painted steel in the finish of the table frame.

TAVOLI DOGATI / SLATTED TABLES / TABLES   LATTES DAUBEN-TISCHE / MESAS LAMINADAS

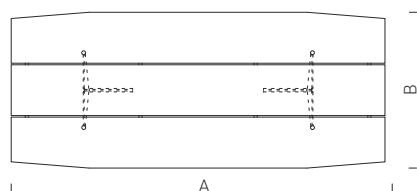
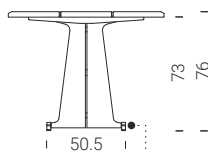
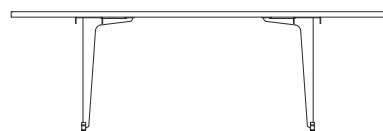

	A x B		T01 T03	T02 T05	T04
ETAV1046	180 x 100	6	4400	4834	4621
ETAV1049	240 x 100	10	5217	6214	5559
ETAV1050	300 x 100	12	6552	7238	6895

esterno **T04**
 outdoor **T04**
 ext rieur **T04**
 drau en **T04**
 exterior **T04**

piedi disponibili in ottone **C31**, ottone scuro **C32** o verniciato a polveri nella finitura del telaio del tavolo.
 feet available in **C31** brass, **C32** dark brass or painted steel in the finish of the table frame.

maggiorazione per esterno riparato solo per surcharge for sheltered outdoor only for majoration pour ext rieur prot g  juste pour Zuschlag f r drau en gesch tzt nur f r aumento para exterior reparado solo para

- T04** **S05** **D01** **L03** **L08** **C35**
S06 **D02** **L06** **L10** **C36**
S07 **D03** **L11**
S08

solo telaio (info pg.100)
 frame only (info on pg.100)
 seulement b ti (info pg.100)
 Ausschlie lich Rahmen (Info pg.100)
 solo marco (informaci n pg.100)

accessori disponibili a pg.180
 accessories available on pg.180
 accessoires disponibles pg. 180
 erh ltliches Zubeh r auf pg.180
 accesorios disponibles en pg.180

disponibili riduzioni a misura
 tailor-made reduction available
 disponibles r ductions sur mesure
 Verkleinerung nach Kundenwunsch
 disponibles reducciones a medida

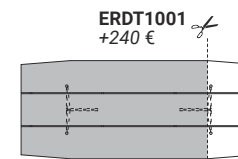
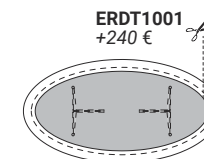

PASSACAVO / CABLE GLAND / PASSE-CÂBLE / KABELDURCHLASS / PASACABLES

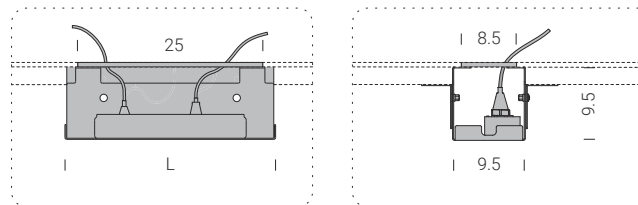
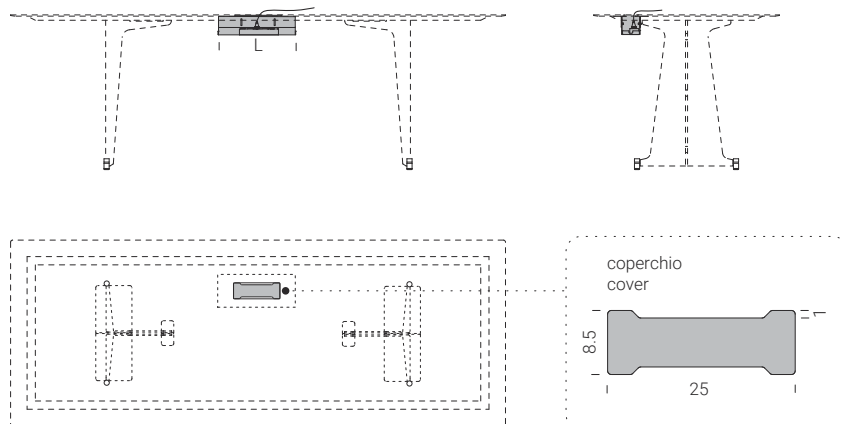

cesto in acciaio e copertura magnetica nelle finiture del tavolo.
steel basket and magnetic cover in the table finishings.
panier en acier et couvercle magnétique dans les mêmes finitions que la table.
Stahlkorb und Magnetabdeckung in der Tischausführung.
cesto de acero y cubierta magnética en los acabados de la mesa.

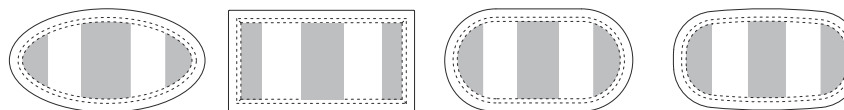

Il passacavi può essere posizionato esclusivamente nelle aree evidenziate.
the cable tidy can be placed only in the highlighted areas
le passe-câbles peut être placé que dans le domaines mis en évidence
das Kabeldurchführung kann nur in den hervorgehobenen Bereichen angeordnet werden
el pasacables se puede colocar sólo en las áreas resaltadas

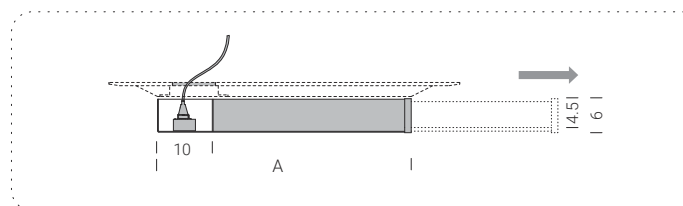
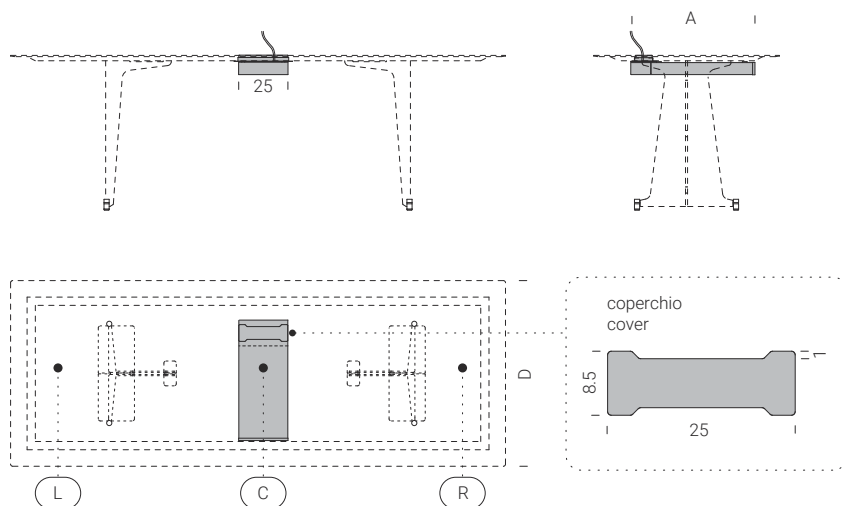
CASSETTO CON PASSACAVO / DRAWER WITH CABLE GLAND / TIROIR AVEC PASSE-CÂBLE
SCHUBLADE MIT KABELDURCHLASS / CAJÓN CON PASACABLES

scocca in acciaio e frontale nelle finiture del tavolo. (il prezzo include la foratura del top tavolo).
Steel body and front in the table finishings. (the price includes perforation of the table top).
coque en acier et façade dans les mêmes finitions que la table. (le prix inclut le perçage du plateau de la table).
Stahllaufbau und Vorderseite in den Tischausführungen. (Die Bohrung der Tischplatte ist im Preis inbegriffen).
chapa de acero y frontal en los acabados de la mesa. (el precio incluye el perforado de la encimera).

ordinabile in posizione L (sinistra), R (destra), C (centrale).
available in the following positions: L (left), R (right), C (central).
peut être commandé en position L (gauche), R (droite), C (centrale).
aufstellbar in Position L (links), R (rechts), C (Mitte).
disponible en posición L (izquierda), R (derecha), C (central).

	L	
SACC0003	28	185
SACC0004	40	205

vedi catalogo a pg.156
refer to catalogue pg.156
Voir catalogue pg. 156
siehe Katalog auf pg.156
véase pg.156 del catálogo

	A x B x C (D)	
GACC0001	47 x 25 x 6 (65)	260
GACC0002	53 x 25 x 6 (78)	280
GACC0003	68 x 25 x 6 (90)	320

vedi catalogo a pg.200 / refer to catalogue pg.200
Voir catalogue pg.200 / siehe Katalog auf pg.200
véase pg.200 del catálogo



ceramica/ceramic/c eramique
Keramik/cer amico

- S05** antracite/anthracite
- S06** nero/black
- S07** porfido/porfido
- S08** cardoso/cardoso



HPL POLARIS®

- L03** bianco/white
 - L10** grigio chiaro/light grey
 - L11** grigio scuro/dark grey
- HPL FENIX®
- L08** grigio Londra/London grey
 - L06** nero/black



HPL+ cemento/concrete/ciment
zement/cemento

- D01** bianco calce/lime white
- D02** grigio Portland/Portland grey
- D03** nero/black

HPL+ metallo/metal/m etal/Metall/metal

- C31** ottone/brass
- C32** ottone scuro/dark brass
- C35** inox/inox
- C36** inox scuro/dark inox

CASSETTO / DRAWER / TIROIR / SCHUBLADE / CAJ N

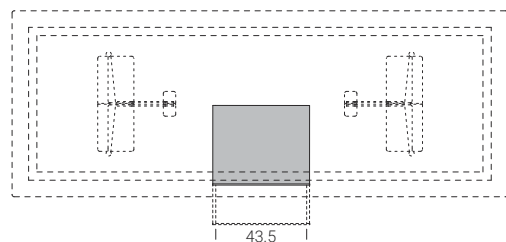
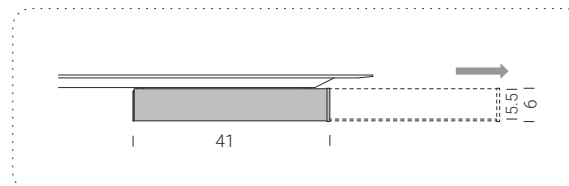
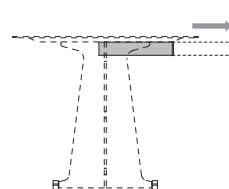
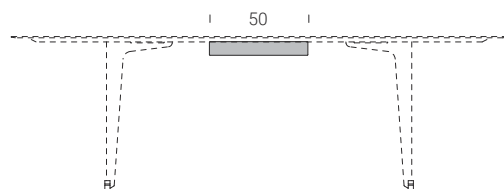

scocca in acciaio e frontale nelle finiture del tavolo.
Steel body and front in the table finishings.
coque en acier et fa ade dans les m emes finitions que la table.
Stahlaufbau und Vorderseite in den Tischausf hrungen.
chapa de acero y frontal en los acabados de la mesa.

⚠ disponibile per tavoli a partire da lunghezza 220 cm
available for tables starting from a length of 220 cm
disponible pour les tables   partir de 220 cm de longueur
verf gbar f r Tische ab einer L nge von 220 cm
disponible para mesas desde 220 cm de longitud

	A x B x C	
SACC0006	50 x 41 x 6	368

vedi catalogo a pg.206
refer to catalogue pg.206
Voir catalogue pg.206
siehe Katalog auf pg.206
v ase pg.206 del cat logo

VASSOI / TRAYS / PLATEAUX / TABLETS / BANDEJAS

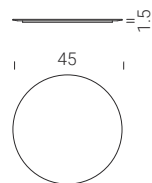

	S05	S06	S07	S08	L03	L06	L08	L10	L11	D01	D02	D03	C31	C32	C35	C36
SACC0007	45 x 1.5	190	165	180	205	245										

vedi catalogo a pg.172 / refer to catalogue pg.172
Voir catalogue pg. 172 / siehe Katalog auf pg.172
v ase pg.172 del cat logo

T11



PROGETTARE UN TELAIO A TRALICCIO CI HA PERMESSO DI RIDURRE LE SEZIONI DEI PROFILI IN ACCIAIO AL MINIMO: SOLI 8 O 16 MM DI DIAMETRO, CHE UNA VOLTA PIEGATI E SALDATI, SOSTENGONO TAVOLI CON DIMENSIONI SINO A 300 CM. T11 È DISPONIBILE IN VERSIONE FISSA E ALLUNGABILE. LA VERSIONE FISSA È CONFIGURABILE CON 8 GEOMETRIE DI TOP DISPONIBILI E IN 8 CATEGORIE DI FINITURE, MENTRE PER I BASAMENTI LA SCELTA È TRA 11 COLORAZIONI A POLVERI.

The trellis frame has allowed us to minimize the sections of the steel profiles: just 8 or 16 mm in diameter which, once bent and welded, support tables of up to 300 cm. T11 is available in fixed and extendible version. The fixed version can have 8 geometries of top available in 8 types of finish, while for the bases there is a choice of 11 powder coated colours.

La conception d'un cadre en treillis a permis de réduire au minimum les sections des profilés en acier lesquels, avec seulement 8 ou 16 mm de diamètre, pliés et soudés, supportent des tables allant jusqu'à 300 cm. T11 est disponible en version fixe et extensible. La version fixe peut être configurée en choisissant parmi 8 formes de plateau, disponibles en 8 catégories de finitions, tandis que 11 couleurs de poudre sont disponibles pour les socles.

Der Entwurf eines Gitterrohrrahmens hat es uns ermöglicht, die Schnitte der Stahlprofile auf das Minimum zu reduzieren: nur 8 oder 16 mm Durchmesser, die nach dem Falten und dem Schweißen Tische mit einer Größe von bis zu 300 cm stützen. T11 ist in fester und ausdehnbarer Version verfügbar. Die feste Version kann mit 8 Tischplattenformen, verfügbar in 8 Beschichtungskategorien, konfiguriert werden, während für das Untergestell zwischen 11 Pulverfärbungen gewählt werden kann.

El diseño de un marco de celosía nos ha permitido reducir las secciones de los perfiles de acero al mínimo: sólo 8 o 16 mm de diámetro, que una vez doblados y soldados, soportan mesas de hasta 300 cm de tamaño. T11 está disponible en versión fija y extensible. La versión fija puede configurarse con 8 geometrías de tablero disponibles y en 8 categorías de acabados, mientras que para las bases se puede elegir entre 11 colores con recubrimiento pulverizado.



Disponibili riduzioni a misura
Custom reductions available
Réductions sur mesure disponibles
Verkürzungen auf Maß erhältlich
Disponibles reducciones a medida



Passacavo disponibile per tutti i top
Cable gland available for all tops
Passe-câble disponible pour tous les plateaux
Kabeldurchlass für alle Abschlussborde verfügbar
Pasacables disponible para todos los sobres



Uso in esterno riparato
Use in a sheltered outdoor space
Utilisation en extérieur, en espace abrité
Verwendung in geschütztem Außenbereich
Uso exterior protegido



EXTENDABLE
TABLE SYSTEM
registered community
design

- acciaio verniciato/painted steel/acier peint
lackierter Stahl/acero pintado
- C12 bianco/white
 - C21 seta/silk
 - C23 corda/ecru
 - C30 ghisa/cast-iron
 - C14 antracite/anthracite
 - C08 nero/black
 - C18 verde/green
 - C26 corten/corten
 - C29 bronzo/bronze
 - C37 rame/copper
 - C38 titanio/titanium

- legno massiccio/solid wood
bois massif/Massivholz
madera maciza
- T01 rovere/oak
 - T02 noce/walnut
 - T03 iroko
 - T04 iroko outdoor
 - T05 rovere nero/black oak

- ceramica/ceramic/c eramique
Keramik/cer amico
- S05 antracite/anthracite
 - S06 nero/black
 - S07 porfido/porfido
 - S08 cardoso/cardoso

- HPL POLARIS®
- L03 bianco/white
 - L10 grigio chiaro/light grey
 - L11 grigio scuro/dark grey
- HPL FENIX®
- L08 grigio Londra/London grey
 - L06 nero/black

- HPL+ legno/wood/bois/Holz/madera
- Y36 rovere/oak
 - Y34 noce/walnut
 - Y37 rovere affumicato/smoked oak
 - Y39 frassino nero/black ash
 - Y40 frassino argilla/clay ash

TAVOLI ALLUNGABILI / EXTENDABLE TABLES / TABLES EXTENSIBLES AUSZIEHBARE TISCHE / MESAS EXTENSIBLES

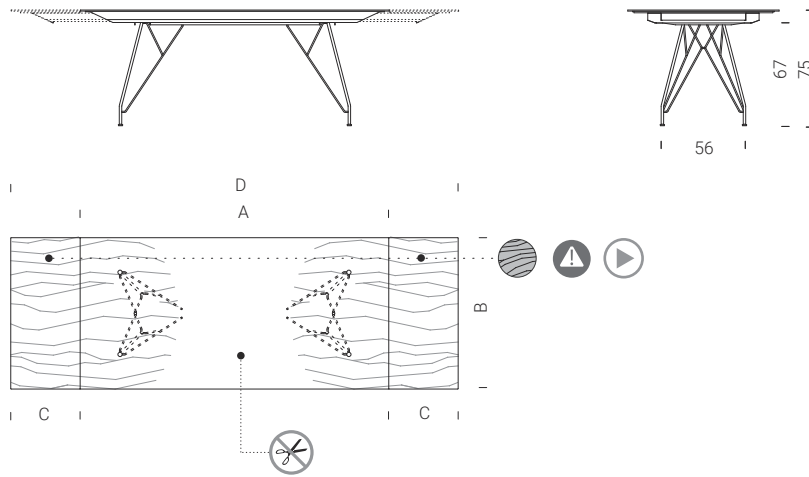

	A / D x B	C		S05 S06 S07 S08	L03 L06	L08 L10 L11	Y36 Y34 Y37 Y39 Y40
ETAV1163	170 / 260 x 90	45+45	6 (10)	4226	3741	4003	4247
ETAV1166	170 / 260 x 98	45+45	6 (10)	4314	3819	4086	4335
ETAV1164	200 / 290 x 90	45+45	8 (12)	4475	3961	4238	4496
ETAV1167	200 / 290 x 98	45+45	8 (12)	4587	4060	4345	4609
ETAV1165	230 / 320 x 90	45+45	10 (12)	4832	4277	4577	4855
ETAV1168	230 / 320 x 98	45+45	10 (12)	4951	4383	4689	4975

le allunghe possono essere posizionate all'interno del tavolo.
the extensions can be positioned inside the table.
les rallonges peuvent  tre plac es   l'int rieur de la table.
die Verl ngerungen k nnen innerhalb des Tisches gelegt werden.
las extensiones pueden colocarse dentro de la mesa.

TAVOLI DOGATI / SLATTED TABLES / TABLES   LATTES DAUBEN-TISCHE / MESAS LAMINADAS

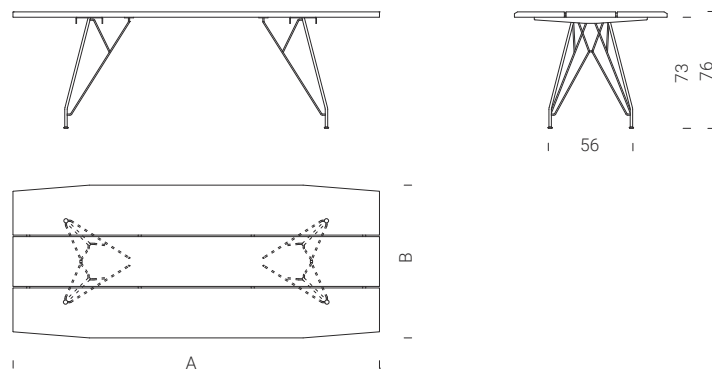

	A x B		T01 T03	T02 T05	
ETAV1158	180 x 100	6	3534	3882	3711
ETAV1161	240 x 100	10	4190	4991	4465
ETAV1162	300 x 100	12	5262	5812	5537

esterno T04
outdoor T04
ext rieur T04
drau en T04
exterior T04

impiallacciatura continua su top e allunghe
continues veneer on top and extensions
les veines du placage bois suivent sur les rallonges
sauberer Furnierverlauf  ber Tisch- und Verl ngerungsplatte
chapa de madera contin a en el plano y extensiones

top e allunghe nella stessa finitura
top and extensions with the same finish
plateau et rallonges dans la m me finition
Abdeck- und Ausziehplatten in derselben Vollendung
Encimera y extensiones en el mismo acabado

Apertura allunghe
Opening of extensions
Ouverture de rallonges
 ffnung verl ngerungsst cke
Apertura de la extensi n

disponibili riduzioni a misura
tailor-made reduction available
disponibles r ductions sur mesure
Verkleinerung nach Kundenwunsch
disponibles reducciones a medida

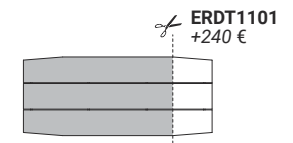

acciaio verniciato/painted steel/acier peint
lackierter Stahl/acero pintado

- C12** bianco/white
- C21** seta/silk
- C23** corda/ecru
- C30** ghisa/cast-iron
- C14** antracite/anthracite
- C08** nero/black
- C18** verde/green
- C26** corten/corten
- C29** bronzo/bronze
- C37** rame/copper
- C38** titanio/titanium



legno massiccio/solid wood
bois massif/Massivholz
madera maciza

- T01** rovere/oak
- T02** noce/walnut
- T03** iroko
- T04** iroko outdoor
- T05** rovere nero/black oak



ceramica/ceramic/c eramique
Keramik/cer mico

- S05** antracite/anthracite
- S06** nero/black
- S07** porfido/porfido
- S08** cardoso/cardoso



HPL POLARIS®

- L03** bianco/white
- L10** grigio chiaro/light grey
- L11** grigio scuro/dark grey

HPL FENIX®

- L08** grigio Londra/London grey
- L06** nero/black



HPL+ cemento/concrete/ciment
zement/cemento

- D01** bianco calce/lime white
- D02** grigio Portland/Portland grey
- D03** nero/black

HPL+ metallo/metal/m tal/Metall/metal

- C31** ottone/brass
- C32** ottone scuro/dark brass
- C35** inox/inox
- C36** inox scuro/dark inox



HPL+ legno/wood/bois/Holz/madera

- Y36** rovere/oak
- Y34** noce/walnut
- Y37** rovere affumicato/smoked oak
- Y39** frassino nero/black ash
- Y40** frassino argilla/clay ash

HPL+ ecotouch

- N01** sabbia/sand
- N02** basalto/basalt

TAVOLI RETTANGOLARI / RECTANGULAR TABLES / TABLES RECTANGULAIRES
RECHTECKIGE TISCHE / MESAS RECTANGULARES

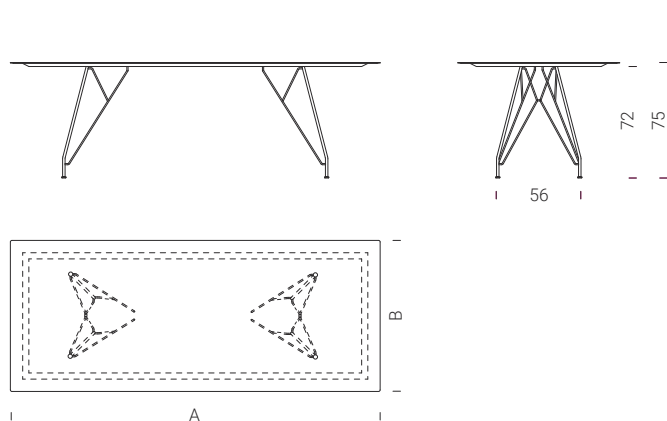

	A x B		T01 T03 T04	T02 T05	S05 S06	S07 S08	L03 L06	L08 L10 L11	D01 D02 D03	C31 C32 C35 C36	Y36 Y34 Y37 Y39 Y40	N01 N02		
ETAV1101	120 x 78	4	1625	1762	1692	1692	1483	1560	1719	2172	1698	1593	983	+177
ETAV1102	160 x 78	6	2062	2116	1894	1894	1662	1761	1931	2540	1911	1763	1102	+177
ETAV1103	180 x 78	8	2199	2269	2036	2036	1767	1875	2053	2732	2032	1864	1172	+177
ETAV1104	200 x 78	8	2329	2455	2199	2199	1908	2036	2229	2979	2207	2021	1223	+275
ETAV1105	120 x 90	6	1872	1899	1739	1739	1518	1605	1763	2285	1743	1618	1007	+177
ETAV1106	160 x 90	6	2193	2276	2048	2048	1782	1892	2070	2763	2051	1877	1182	+177
ETAV1107	180 x 90	8	2347	2451	2237	2237	1982	2103	2261	3038	2253	2043	1316	+177
ETAV1108	200 x 90	8	2515	2657	2365	2365	2044	2187	2388	3242	2367	2148	1357	+275
ETAV1109	220 x 90	8	2707	2863	2490	2490	2179	2336	2546	3766	2526	2280	1397	+275
ETAV1110	240 x 90	10	2906	3321	2772	2772	2400	2569	2801	4121	2778	2510	1539	+275
ETAV1111	180 x 98	8	2459	2589	2291	2291	1991	2121	2314	3158	2295	2077	1321	+177
ETAV1112	200 x 98	8	2531	2817	2480	2480	2146	2299	2507	3433	2486	2246	1376	+275
ETAV1113	220 x 98	8	2715	3031	2634	2634	2298	2465	2684	4007	2664	2394	1473	+275
ETAV1114	240 x 98	10	2915	3327	2918	2918	2530	2710	2951	4385	2929	2635	1622	+275
ETAV1115	300 x 98	12	3660	3875	3413	3413	2989	3206	3485	5268	3460	3092	1916	+275
ETAV1116	200 x 110	8	2784	3099	2728	2728	2361	2529	2758	3776	2735	2470	1513	+275
ETAV1117	220 x 110	8	2986	3334	2897	2897	2528	2712	2952	4408	2930	2633	1620	+275
ETAV1118	240 x 110	10	3159	3538	3209	3209	2783	2981	3247	4823	3222	2899	1784	+275
ETAV1119	300 x 110	8	4027	4263	3754	3754	3288	3526	3833	5795	3806	3401	2108	+275

maggiorazione per esterno riparato solo per surcharge for sheltered outdoor only for majoration pour ext rieur prot g  juste pour Zuschlag f r drau en gesch tzt nur f r aumento para exterior reparado solo para

T04 S05 D01 L03 L08 C35
S06 D02 L06 L10 C36
S07 D03 L11
S08

solo telaio (info pg.101)
frame only (info on pg.101)
seulement b ti (info pg.101)
Ausschlie lich Rahmen (Info pg.101)
solo marco (informaci n pg.101)

accessori disponibili a pg.188
accessories available on pg.188
accessoires disponibles pg. 188
erh ltliches Zubeh r auf pg.188
accesorios disponibles en pg.188

disponibili riduzioni a misura
tailor-made reduction available
disponibles r ductions sur mesure
Verkleinerung nach Kundenwunsch
disponibles reducciones a medida

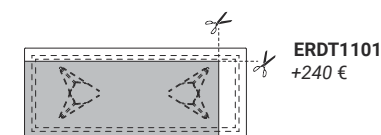

- acciaio verniciato/painted steel/acier peint
lackierter Stahl/acero pintado
- C12** bianco/white
 - C21** seta/silk
 - C23** corda/ecru
 - C30** ghisa/cast-iron
 - C14** antracite/anthracite
 - C08** nero/black
 - C18** verde/green
 - C26** corten/corten
 - C29** bronzo/bronze
 - C37** rame/copper
 - C38** titanio/titanium

- legno massiccio/solid wood
bois massif/Massivholz
madera maciza
- T01** rovere/oak
 - T02** noce/walnut
 - T03** iroko
 - T04** iroko outdoor
 - T05** rovere nero/black oak

- ceramica/ceramic/c eramique
Keramik/cer amico
- S05** antracite/anthracite
 - S06** nero/black
 - S07** porfido/porfido
 - S08** cardoso/cardoso

- HPL POLARIS®
- L03** bianco/white
 - L10** grigio chiaro/light grey
 - L11** grigio scuro/dark grey
- HPL FENIX®
- L08** grigio Londra/London grey
 - L06** nero/black

- HPL+ cemento/concrete/ciment
zement/cemento
- D01** bianco calce/lime white
 - D02** grigio Portland/Portland grey
 - D03** nero/black
- HPL+ metallo/metal/m etal/Metall/metal
- C31** ottone/brass
 - C32** ottone scuro/dark brass
 - C35** inox/inox
 - C36** inox scuro/dark inox

- HPL+ legno/wood/bois/Holz/madera
- Y36** rovere/oak
 - Y34** noce/walnut
 - Y37** rovere affumicato/smoked oak
 - Y39** frassino nero/black ash
 - Y40** frassino argilla/clay ash
- HPL+ ecotouch
- N01** sabbia/sand
 - N02** basalto/basalt

**TAVOLI A TESTA TONDA / ROUND HEAD TABLES / TABLES AUX EXTR MIT S ARRONDIES
RUNDER KOPF TISCHE / MESAS REDONDAS DE ESTRUCTURA LINEAL**

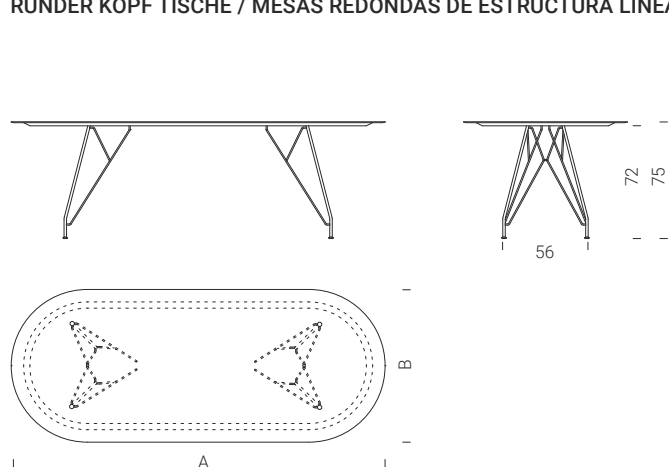

	A x B		T01 T03 T04	T02 T05	S05 S06	S07 S08	L03 L06	L08 L10 L11	D01 D02 D03	C31 C32 C35 C36	Y36 Y34 Y37 Y39 Y40	N01 N02		
ETAV1122	180 x 78	8	2199	2269	2036	2036	1767	1875	2053	2732	2032	1864	1172	+177
ETAV1123	200 x 78	8	2329	2455	2199	2199	1908	2036	2229	2979	2207	2021	1223	+275
ETAV1124	180 x 90	8	2347	2451	2237	2237	1982	2103	2261	3038	2253	2043	1316	+177
ETAV1125	200 x 90	8	2515	2657	2365	2365	2044	2187	2388	3242	2367	2148	1357	+275
ETAV1126	220 x 90	8	2707	2863	2490	2490	2179	2336	2546	3766	2526	2280	1397	+275
ETAV1127	240 x 90	10	2906	3321	2772	2772	2400	2569	2801	4121	2778	2510	1539	+275
ETAV1128	180 x 98	8	2459	2589	2291	2291	1991	2121	2314	3158	2295	2077	1321	+177
ETAV1129	200 x 98	8	2531	2817	2480	2480	2146	2299	2507	3433	2486	2246	1376	+275
ETAV1130	220 x 98	8	2715	3031	2634	2634	2298	2465	2684	4007	2664	2394	1473	+275
ETAV1131	240 x 98	10	2915	3327	2918	2918	2530	2710	2951	4385	2929	2635	1622	+275
ETAV1132	300 x 98	12	3660	3875	3413	3413	2989	3206	3485	5268	3460	3092	1916	+275

maggiorazione per esterno riparato solo per surcharge for sheltered outdoor only for majoration pour ext rieur prot g e juste pour Zuschlag f r drau en gesch tzt nur f r aumento para exterior reparado solo para

**T04 S05 D01 L03 L08 C35
S06 D02 L06 L10 C36
S07 D03 L11
S08**

solo telaio (info pg.101)
frame only (info on pg.101)
seulement b ti (info pg.101)
Ausschlie lich Rahmen (Info pg.101)
solo marco (informaci n pg.101)

accessori disponibili a pg.188
accessories available on pg.188
accessoires disponibles pg. 188
erh ltliches Zubeh r auf pg.188
accesorios disponibles en pg.188

disponibili riduzioni a misura
tailor-made reduction available
disponibles r ductions sur mesure
Verkleinerung nach Kundenwunsch
disponibles reducciones a medida

ERDT1101
+240  

acciaio verniciato/painted steel/acier peint
lackierter Stahl/acero pintado

- C12** bianco/white
- C21** seta/silk
- C23** corda/ecru
- C30** ghisa/cast-iron
- C14** antracite/anthracite
- C08** nero/black
- C18** verde/green
- C26** corten/corten
- C29** bronzo/bronze
- C37** rame/copper
- C38** titanio/titanium

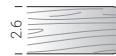

legno massiccio/solid wood
bois massif/Massivholz
madera maciza

- T01** rovere/oak
- T02** noce/walnut
- T03** iroko
- T04** iroko outdoor
- T05** rovere nero/black oak



ceramica/ceramic/c eramique
Keramik/cer mico

- S05** antracite/anthracite
- S06** nero/black
- S07** porfido/porfido
- S08** cardoso/cardoso



HPL POLARIS®

- L03** bianco/white
- L10** grigio chiaro/light grey
- L11** grigio scuro/dark grey

HPL FENIX®

- L08** grigio Londra/London grey
- L06** nero/black



HPL+ cemento/concrete/ciment
zement/cemento

- D01** bianco calce/lime white
- D02** grigio Portland/Portland grey
- D03** nero/black

HPL+ metallo/metal/m tal/Metall/metal

- C31** ottone/brass
- C32** ottone scuro/dark brass
- C35** inox/inox
- C36** inox scuro/dark inox



HPL+ legno/wood/bois/Holz/madera

- Y36** rovere/oak
- Y34** noce/walnut
- Y37** rovere affumicato/smoked oak
- Y39** frassino nero/black ash
- Y40** frassino argilla/clay ash

HPL+ ecotouch

- N01** sabbia/sand
- N02** basalto/basalt

TAVOLI A BOTTE / BARREL VAULT TABLES / TABLES TONNEAU
WEINFASS-TISCHE / MESAS DE BARRIL

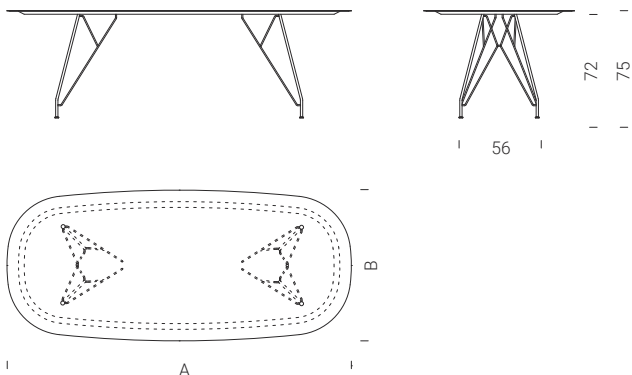

	A x B		T01 T03 T04	T02 T05	S05 S06	S07 S08	L03 L06	L08 L10 L11	D01 D02 D03	C31 C32 C35 C36	Y36 Y34 Y37 Y39 Y40	N01 N02		
ETAV1133	180 x 98	8	2459	2589	2291	2291	1991	2121	2314	3158	2295	2077	1321	+177
ETAV1134	200 x 98	8	2531	2817	2480	2480	2146	2299	2507	3433	2486	2246	1376	+275
ETAV1135	220 x 98	8	2715	3031	2634	2634	2298	2465	2684	4007	2664	2394	1473	+275
ETAV1136	240 x 98	10	2915	3327	2918	2918	2530	2710	2951	4385	2929	2635	1622	+275
ETAV1137	300 x 98	12	3660	3875	3413	3413	2989	3206	3485	5268	3460	3092	1916	+275
ETAV1138	180 x 105	8	2655	2796	2474	2474	2150	2290	2499	3410	2478	2243	1426	+177
ETAV1139	200 x 105	8	2784	3099	2728	2728	2361	2529	2758	3776	2735	2470	1513	+275
ETAV1140	220 x 105	8	2986	3334	2897	2897	2528	2712	2952	4408	2930	2633	1620	+275
ETAV1141	240 x 105	10	3159	3538	3209	3209	2783	2981	3247	4823	3222	2899	1784	+275
ETAV1142	300 x 105	12	4027	4263	3754	3754	3288	3526	3833	5795	3806	3401	2108	+275

TAVOLI OVALI / OVAL TABLES / TABLES OVALES
OVALTISCHE / MESAS OVALADAS

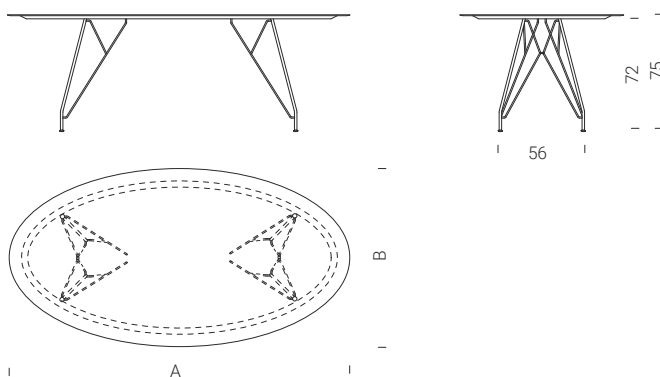

	A x B		T01 T03 T04	T02 T05	S05 S06	S07 S08	L03 L06	L08 L10 L11	D01 D02 D03	C31 C32 C35 C36	Y36 Y34 Y37 Y39 Y40	N01 N02		
ETAV1145	160 x 85	6	2098	2184	2009	2009	1683	1788	1956	2598	1937	1773	1079	+177
ETAV1146	180 x 95	8	2422	2530	2282	2282	1921	2048	2172	3043	2216	2004	1231	+177
ETAV1147	200 x 105	8	2710	3017	2613	2613	2194	2358	2565	3841	2546	2283	1406	+275
ETAV1148	220 x 115	8	3097	3468	2972	2972	2503	2694	2922	4453	2905	2582	1605	+275
ETAV1149	248 x 128	10	3273	3758	3195	-	3020	3253	-	-	3504	3096	1936	+275

maggiorazione per esterno riparato solo per surcharge for sheltered outdoor only for majoration pour ext rieur prot g  juste pour Zuschlag f r drau en gesch tzt nur f r aumento para exterior reparado solo para

T04 S05 D01 L03 L08 C35
S06 D02 L06 L10 C36
S07 D03 L11
S08

solo telaio (info pg.101)
frame only (info on pg.101)
seulement b ti (info pg.101)
Ausschlie lich Rahmen (Info pg.101)
solo marco (informaci n pg.101)

accessori disponibili a pg.188
accessories available on pg.188
accessoires disponibles pg. 188
erh ltliches Zubeh r auf pg.188
accesorios disponibles en pg.188

disponibili riduzioni a misura
tailor-made reduction available
disponibles r ductions sur mesure
Verkleinerung nach Kundenwunsch
disponibles reducciones a medida

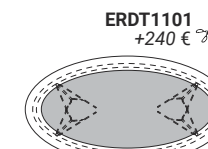
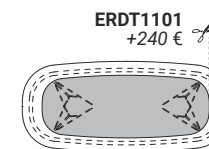

acciaio verniciato/painted steel/acier peint
lackierter Stahl/acero pintado

C12 bianco/white
C21 seta/silk
C23 corda/ecru
C30 ghisa/cast-iron
C14 antracite/anthracite
C08 nero/black
C18 verde/green
C26 corten/corten
C29 bronzo/bronze
C37 rame/copper
C38 titanio/titanium

legno massiccio/solid wood
bois massif/Massivholz
madera maciza

T01 rovere/oak
T02 noce/walnut
T03 iroko
T04 iroko outdoor
T05 rovere nero/black oak

ceramica/ceramic/c eramique
Keramik/cer mico

S05 antracite/anthracite
S06 nero/black
S07 porfido/porfido
S08 cardoso/cardoso

HPL POLARIS®

L03 bianco/white
L10 grigio chiaro/light grey
L11 grigio scuro/dark grey

HPL FENIX®

L08 grigio Londra/London grey
L06 nero/black

HPL+ cemento/concrete/ciment
zement/cemento

D01 bianco calce/lime white
D02 grigio Portland/Portland grey
D03 nero/black

HPL+ metallo/metal/m tal/Metall/metal

C31 ottone/brass
C32 ottone scuro/dark brass
C35 inox/inox
C36 inox scuro/dark inox

HPL+ legno/wood/bois/Holz/madera

Y36 rovere/oak
Y34 noce/walnut
Y37 rovere affumicato/smoked oak
Y39 frassino nero/black ash
Y40 frassino argilla/clay ash

HPL+ ecotouch

N01 sabbia/sand
N02 basalto/basalt

TAVOLI TONDI / ROUND TABLES / TABLES RONDES
RUNDTISCHE TISCHE / MESAS REDONDAS

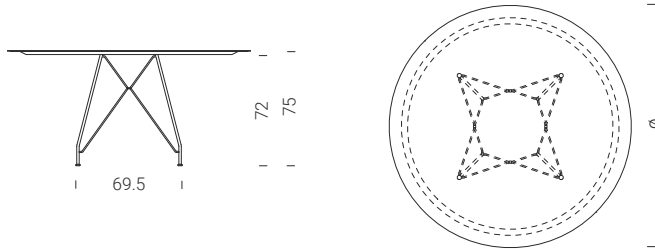

	∅	6	T01 T03 T04	T02 T05	S05 S06	S07 S08	L03 L06	L08 L10 L11	D01 D02 D03	C31 C32 C35 C36	Y36 Y34 Y37 Y39 Y40	N01 N02	1217	+177
ETAV1150	128	6	2303	2543	2182	-	1898	2033	-	-	2201	2000	1217	+177
ETAV1151	140	7	2727	2859	2388	-	2077	2208	-	-	2385	2139	1331	+275
ETAV1152	160	8	2984	3224	2801	-	2436	2598	-	-	2799	2470	1562	+275

TAVOLI QUADRATI A BOTTE / SQUARE BARREL TABLES / TABLES   TONNEAU CARR ES
VIERECKIGE TONNENF RMIGE TISCHE / MESAS CUADRADAS

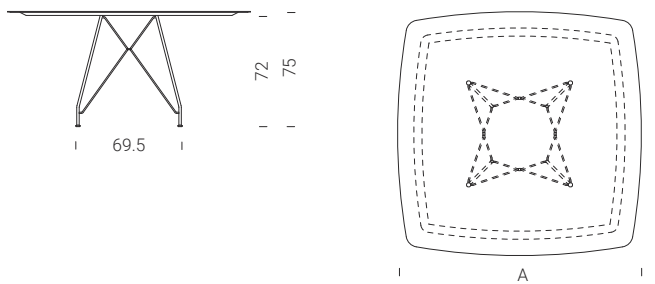

	A x B	6	T01 T03 T04	T02 T05	S05 S06	S07 S08	L03 L06	L08 L10 L11	D01 D02 D03	C31 C32 C35 C36	Y36 Y34 Y37 Y39 Y40	N01 N02	1401	+177
ETAV1143	120 x 120	6	2354	2479	2197	2197	1907	2031	2215	3024	2198	1989	1401	+177
ETAV1144	140 x 140	8	2651	2802	2478	-	2156	2349	-	-	2536	2252	1480	+275

TAVOLI QUADRATI / SQUARE TABLES / TABLES CARR ES
QUADRATISCHE TISCHE / MESAS CUADRADAS

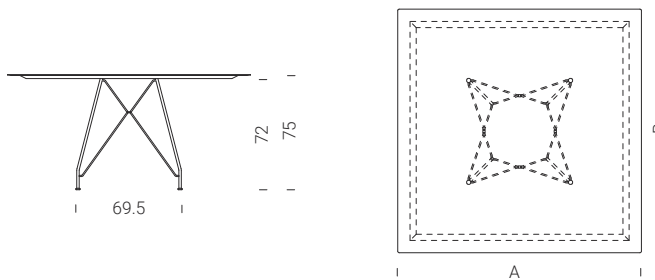

	A x B	6	T01 T03 T04	T02 T05	S05 S06	S07 S08	L03 L06	L08 L10 L11	D01 D02 D03	C31 C32 C35 C36	Y36 Y34 Y37 Y39 Y40	N01 N02	1401	+177
ETAV1120	120 x 120	6	2354	2479	2197	2197	1907	2031	2215	3024	2198	1989	1401	+177
ETAV1121	140 x 140	8	2651	2802	2478	-	2156	2349	-	-	2536	2252	1480	+275

maggiorazione per esterno riparato solo per surcharge for sheltered outdoor only for majoration pour ext rieur prot g  juste pour Zuschlag f r drau en gesch tzt nur f r aumento para exterior reparado solo para

T04 S05 D01 L03 L08 C35
S06 D02 L06 L10 C36
S07 D03 L11
S08

sofo telaio (info pg.101)
frame only (info on pg.101)
seulement b ti (info pg.101)
Ausschlie lich Rahmen (Info pg.101)
sofo marco (informaci n pg.101)

accessori disponibili a pg.188
accessories available on pg.188
accessoires disponibles pg.188
erh ltliches Zubeh r auf pg.188
accesorios disponibles en pg.188

disponibili riduzioni a misura
tailor-made reduction available
disponibles r ductions sur mesure
Verkleinerung nach Kundenwunsch
disponibles reducciones a medida

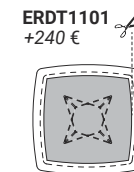
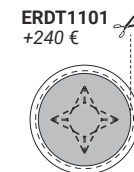

PASSACAVO / CABLE GLAND / PASSE-CÂBLE / KABELDURCHLASS / PASACABLES

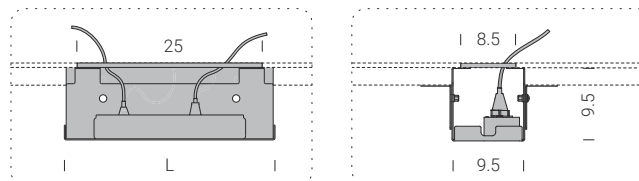
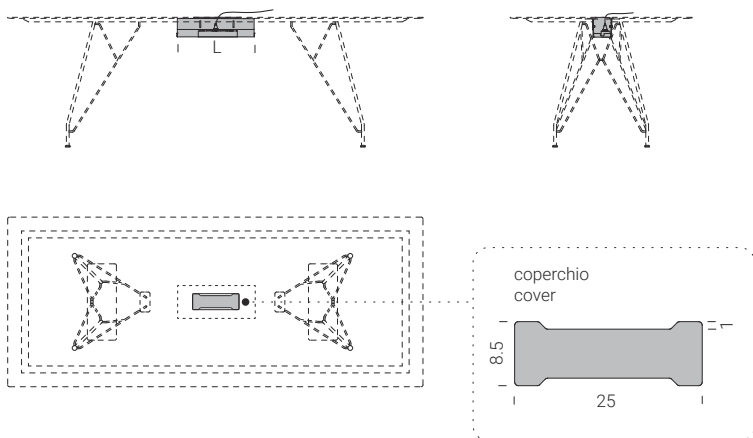

cesto in acciaio e copertura magnetica nelle finiture del tavolo.
steel basket and magnetic cover in the table finishings.
panier en acier et couvercle magnétique dans les mêmes finitions que la table.
Stahlkorb und Magnetabdeckung in der Tischausführung.
cesto de acero y cubierta magnética en los acabados de la mesa.

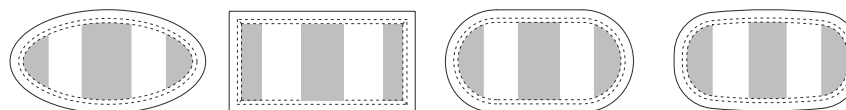

Il passacavi può essere posizionato esclusivamente nelle aree evidenziate.
the cable tidy can be placed only in the highlighted areas
le passe-câbles peut être placé que dans les domaines mis en évidence
das Kabeldurchführung kann nur in den hervorgehobenen Bereichen angeordnet werden
el pasacables se puede colocar sólo en las áreas resaltadas

	L	
SACC0003	28	185
SACC0004	40	205

vedi catalogo a pg.156
refer to catalogue pg.156
Voir catalogue pg. 156
siehe Katalog auf pg.156
véase pg.156 del catálogo

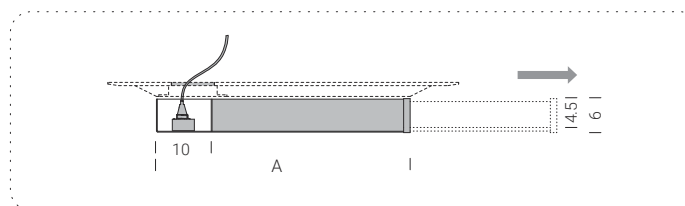
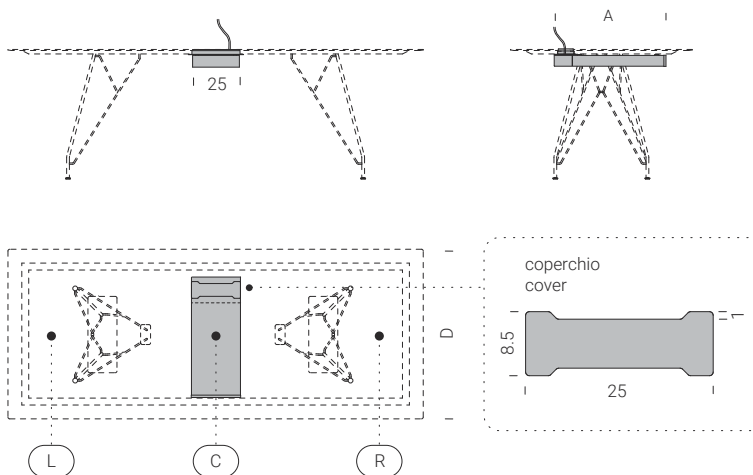
CASSETTO CON PASSACAVO / DRAWER WITH CABLE GLAND / TIROIR AVEC PASSE-CÂBLE
SCHUBLADE MIT KABELDURCHLASS / CAJÓN CON PASACABLES

cassetto in acciaio e frontale nelle finiture del tavolo. (il prezzo include la foratura del top tavolo).
steel drawer and front in the table finishings. (the price includes perforation of the table top).
tiroir en acier et façade dans les mêmes finitions que la table. (le prix inclut le perçage du plateau de la table).
Stahlschublade und Vorderseite in den Tischausführungen. (Die Bohrung der Tischplatte ist im Preis inbegriffen).
cajón de acero y frontal en los acabados de la mesa. (el precio incluye el perforado de la encimera).

ordinabile in posizione L (sinistra), R (destra), C (centrale).
available in the following positions: L (left), R (right), C (central).
peut être commandé en position L (gauche), R (droite), C (centrale).
aufstellbar in Position L (links), R (rechts), C (Mitte).
disponible en posición L (izquierda), R (derecha), C (central).

	A x B x C (D)	
GACC0002	53 x 25 x 6 (78)	280
GACC0003	68 x 25 x 6 (90)	320

vedi catalogo a pg.200 / refer to catalogue pg.200
Voir catalogue pg.200 / siehe Katalog auf pg.200
véase pg.200 del catálogo



ceramica/ceramic/c eramique
Keramik/cer amico

- S05** antracite/anthracite
- S06** nero/black
- S07** porfido/porfido
- S08** cardoso/cardoso



HPL POLARIS®

- L03** bianco/white
- L10** grigio chiaro/light grey
- L11** grigio scuro/dark grey

HPL FENIX®

- L08** grigio Londra/London grey
- L06** nero/black



HPL+ cemento/concrete/ciment
zement/cemento

- D01** bianco calce/lime white
- D02** grigio Portland/Portland grey
- D03** nero/black

HPL+ metallo/metal/m etal/Metall/metal

- C31** ottone/brass
- C32** ottone scuro/dark brass
- C35** inox/inox
- C36** inox scuro/dark inox

CASSETTO / DRAWER / TIROIR / SCHUBLADE / CAJ N

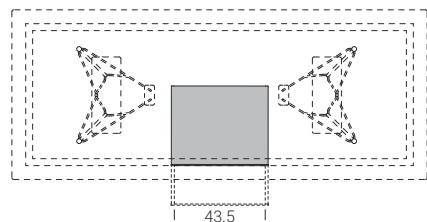
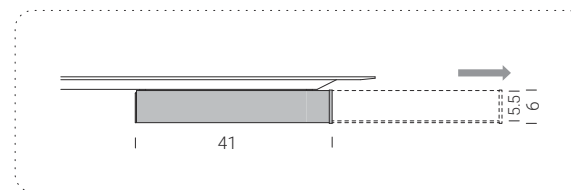
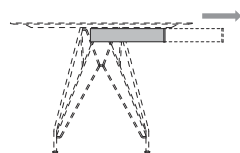
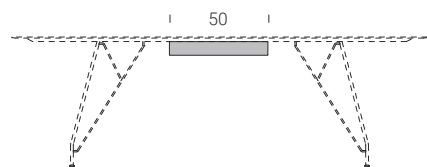

A x B x C

SACC0006	50 x 41 x 6	368
-----------------	-------------	-----

vedi catalogo a pg.206
refer to catalogue pg.206
Voir catalogue pg.206
siehe Katalog auf pg.206
v ase pg.206 del cat logo

scocca in acciaio e frontale nelle finiture del tavolo.
Steel body and front in the table finishings.
coque en acier et fa ade dans les m mes finitions que la table.
Stahlaufbau und Vorderseite in den Tischausf hrungen.
chapa de acero y frontal en los acabados de la mesa.



disponibile per tavoli a partire da lunghezza 220 cm
available for tables at least 220 cm long
disponible pour des tables   partir d'une longueur de 220 cm
Erh ltlich f r Tische ab einer Tischl nge von 220 cm
disponible para mesas desde 220 cm de longitud

VASSOI / TRAYS / PLATEAUX / TABLETS / BANDEJAS

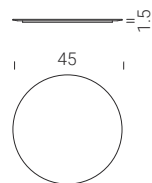

S05			L08	D01	C31
S06			L10	D02	C32
S07	L03		L11	D03	C35
S08	L06				C36

SACC0007	45 x 1.5	190	165	180	205	245
-----------------	----------	-----	-----	-----	-----	-----

vedi catalogo a pg.172 / refer to catalogue pg.172
Voir catalogue pg.172 / siehe Katalog auf pg.172
v ase pg.172 del cat logo

T12



PENSARE AD UN TAVOLO ISPIRATO ALLE STRUTTURE DEI PONTI HA RESO POSSIBILE LA PRODUZIONE DI TOP DI 400 CM DI LUNGHEZZA IN UN UNICO PEZZO. IL SISTEMA A TIRANTI TENSIONABILI DEL BASAMENTO RENDE LA STRUTTURA ESTREMAMENTE RIGIDA ALLE SOLLECITAZIONI LATERALI E GARANTISCE LA PERFETTA PLANARITÀ DEL TOP.

Designing a table inspired by bridge structures has made it possible to produce a 400 cm top in a single piece. The tensioning tie rods system of the base makes the structure extremely robust and resistant to lateral stresses and guarantees perfect planarity of the top.

Penser à une table inspirée des structures de pont a permis de produire des plateaux de 400 cm de long réalisés en un unique morceau. Le système de tirants tendus du socle rend la structure extrêmement rigide face aux sollicitations latérales, avec garantie d'une planéité parfaite du plateau.

Der Gedanke an einem an die Strukturen der Brücken inspirierten Tisch hat es ermöglicht, eine 400 cm lange Tischplatte aus einem einzigen Stück zu produzieren. Das spannbare Zugstabsystem des Untergestells macht die Struktur extrem beständig gegen seitliche Beanspruchungen und gewährleistet die perfekte Ebenheit der Tischplatte.

Pensar en una mesa inspirada en las estructuras de los puentes permitió fabricar un tablero de 400 cm de largo en una sola pieza. El sistema de tensado de la base hace que la estructura sea extremadamente rígida a los esfuerzos laterales y garantiza la perfecta planitud de la parte superior.



Disponibili riduzioni a misura
Custom reductions available
Réductions sur mesure disponibles
Verkürzungen auf Maß erhältlich
Disponibles reducciones a medida



Passacavo disponibile per tutti i top
Cable gland available for all tops
Passe-câble disponible pour tous les plateaux
Kabeldurchlass für alle Abschlussborde verfügbar
Pasacables disponible para todos los sobres



Possibilità di affiancamento
Possibility to place by side
Possibilité d'association
Aufstellung nebeneinander möglich
Posibilidad de colocarse uno al lado del otro

- acciaio verniciato/painted steel/acier peint
lackierter Stahl/acero pintado
- C12** bianco/white
 - C21** seta/silk
 - C23** corda/ecru
 - C30** ghisa/cast-iron
 - C14** antracite/anthracite
 - C08** nero/black
 - C18** verde/green
 - C26** corten/corten
 - C29** bronzo/bronze
 - C37** rame/copper
 - C38** titanio/titanium

- ceramica/ceramic/c eramique
Keramik/cer mico
- S05** antracite/anthracite
 - S06** nero/black
 - S07** porfido/porfido
 - S08** cardoso/cardoso

- HPL POLARIS®
- L03** bianco/white
 - L10** grigio chiaro/light grey
 - L11** grigio scuro/dark grey
- HPL FENIX®
- L08** grigio Londra/London grey
 - L06** nero/black

- HPL+ cemento/concrete/ciment
zement/cemento
- D01** bianco calce/lime white
 - D02** grigio Portland/Portland grey
 - D03** nero/black
- HPL+ metallo/metal/m tal/Metall/metal
- C31** ottone/brass
 - C32** ottone scuro/dark brass
 - C35** inox/inox
 - C36** inox scuro/dark inox

- HPL+ legno/wood/bois/Holz/madera
- Y36** rovere/oak
 - Y34** noce/walnut
 - Y37** rovere affumicato/smoked oak
 - Y39** frassino nero/black ash
 - Y40** frassino argilla/clay ash
- HPL+ ecotouch
- N01** sabbia/sand
 - N02** basalto/basalt

TAVOLI RETTANGOLARI / RECTANGULAR TABLES / TABLES RECTANGULAIRES
RECHTECKIGE TISCHE / MESAS RECTANGULARES

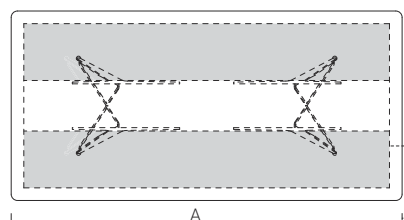
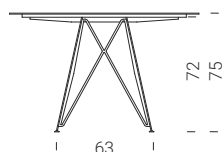
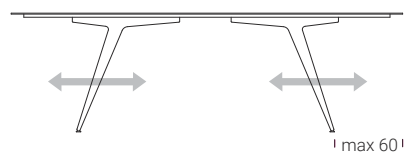

rinforzi in alluminio
aluminium reinforcements
renforts en aluminium
Verst rkungen aus Aluminium
refuerzos de aluminio

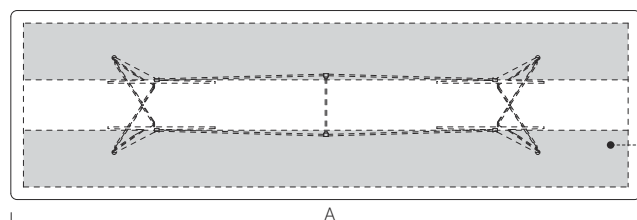
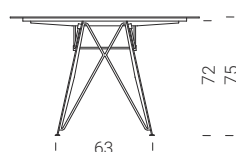
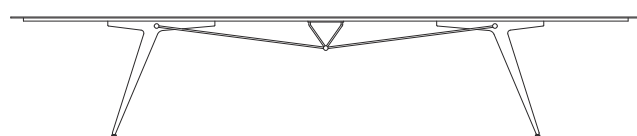

rinforzi in alluminio
aluminium reinforcements
renforts en aluminium
Verst rkungen aus Aluminium
refuerzos de aluminio

	A x B		S05 S06	S07 S08	L03 L06	L08 L10 L11	D01 D02 D03	C31 C32 C35 C36	Y36 Y34 Y37 Y39 Y40	N01 N02	
ETAV1201	200 x 90	8	3636	3636	3134	3354	3667	4858	3605	3291	+315
ETAV1202	220 x 90	8	3795	3795	3272	3501	3828	5072	3763	3436	+315
ETAV1203	240 x 90	10	3980	3980	3431	3671	4014	5318	3946	3603	+315
ETAV1204	260 x 90	10	4150	4150	3577	3828	4185	5545	4114	3756	+315
ETAV1205	280 x 90	12	4334	4334	3736	3998	4371	5791	4297	3923	+315
ETAV1206	200 x 100	8	3641	3641	3139	3358	3672	4865	3609	3296	+315
ETAV1207	220 x 100	8	3800	3800	3276	3506	3833	5078	3768	3440	+315
ETAV1208	240 x 100	10	3985	3985	3435	3676	4019	5325	3951	3607	+315
ETAV1209	260 x 100	10	4170	4170	3594	3846	4205	5571	4134	3774	+315
ETAV1210	280 x 100	12	4354	4354	3754	4016	4392	5818	4317	3941	+315
ETAV1211	220 x 120	8	3820	-	3293	3524	3853	5105	3787	3458	+315
ETAV1212	240 x 120	10	4005	-	3453	3694	4039	5351	3970	3625	+315
ETAV1213	260 x 120	10	4189	-	3612	3864	4226	5598	4153	3792	+315
ETAV1214	280 x 120	12	4374	-	3771	4035	4412	5845	4336	3959	+315

	A x B		S05 S06	S07 S08	L03 L06	L08 L10 L11	D01 D02 D03	C31 C32 C35 C36	Y36 Y34 Y37 Y39 Y40	N01 N02	
ETAV1215	300 x 90	12	4919	4919	4293	4566	4958	6445	4879	4488	+415
ETAV1216	300 x 100	12	4934	4934	4305	4580	4973	6465	4894	4502	+415
ETAV1217	300 x 120	12	4963	-	4331	4608	5003	6504	4924	4529	+415
ETAV1218	360 x 120	14	-	-	4796	5105	-	-	-	5016	+415
ETAV1219	400 x 120	16	-	-	5314	5660	-	-	-	5561	+415

maggiorazione per esterno riparato solo per surcharge for sheltered outdoor only for majoration pour ext rieur prot g  juste pour Zuschlag f r drau en gesch tzt nur f r aumento para exterior reparado solo para

- S05 D01 L03 L08 C35
S06 D02 L06 L10 C36
S07 D03 L11
S08

accessori a pg.195
accessories on pg.195
accessoires pg.195
Zubeh r auf pg.195
accesorios en pg.195

disponibili riduzioni a misura
tailor-made reduction available
disponibles r ductions sur mesure
Verkleinerung nach Kundenwunsch
disponibles reducciones a medida

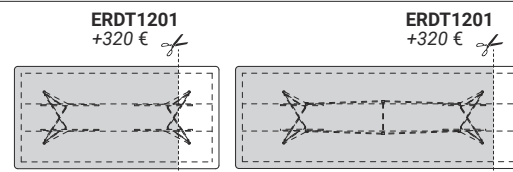

Caratteristiche costruttive
Construction characteristics
Caract ristiques de construction
Konstruktionsmerkmale
Caracter sticas constructivas

- acciaio verniciato/painted steel/acier peint
lackierter Stahl/acero pintado
- C12 bianco/white
 - C21 seta/silk
 - C23 corda/ecru
 - C30 ghisa/cast-iron
 - C14 antracite/anthracite
 - C08 nero/black
 - C18 verde/green
 - C26 corten/corten
 - C29 bronzo/bronze
 - C37 rame/copper
 - C38 titanio/titanium

- ceramica/ceramic/c eramique
Keramik/cer mico
- S05 antracite/anthracite
 - S06 nero/black
 - S07 porfido/porfido
 - S08 cardoso/cardoso

- HPL POLARIS®
- L03 bianco/white
 - L10 grigio chiaro/light grey
 - L11 grigio scuro/dark grey
- HPL FENIX®
- L08 grigio Londra/London grey
 - L06 nero/black

- HPL+ cemento/concrete/ciment
zement/cemento
- D01 bianco calce/lime white
 - D02 grigio Portland/Portland grey
 - D03 nero/black
- HPL+ metallo/metal/m tal/Metall/metal
- C31 ottone/brass
 - C32 ottone scuro/dark brass
 - C35 inox/inox
 - C36 inox scuro/dark inox

- HPL+ legno/
wood/bois/Holz/madera
- Y36 rovere/oak
 - Y34 noce/walnut
 - Y37 rovere affumicato/smoked oak
 - Y39 frassino nero/black ash
 - Y40 frassino argilla/clay ash
- HPL+ ecotouch
- N01 sabbia/sand
 - N02 basalto/basalt

TAVOLI A BOTTE / BARREL VAULT TABLES / TABLES TONNEAU
WEINFASS-TISCHE / MESAS DE BARRIL

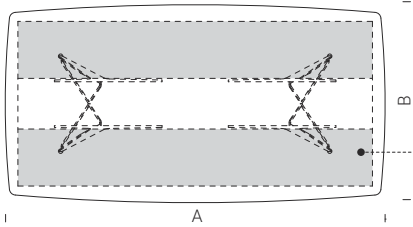
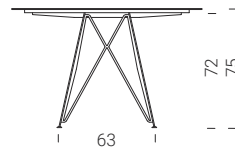
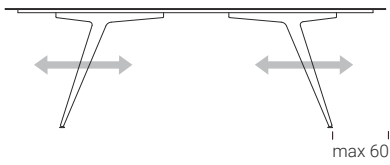

rinforzi in alluminio
aluminium reinforcements
renforts en aluminium
Verst rkungen aus Aluminium
refuerzos de aluminio

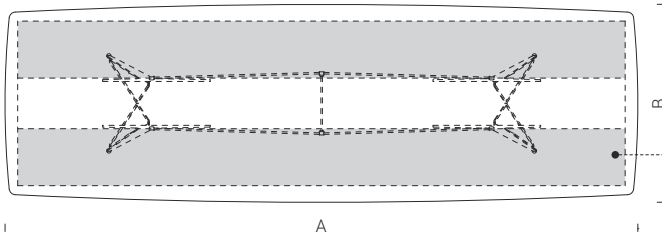
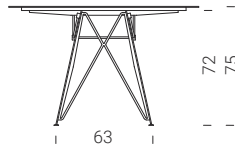
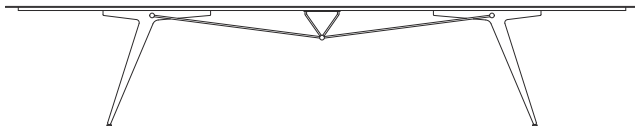

rinforzi in alluminio
aluminium reinforcements
renforts en aluminium
Verst rkungen aus Aluminium
refuerzos de aluminio

	A x B		S05 S06	S07 S08	L03 L06	L08 L10 L11	D01 D02 D03	C31 C32 C35 C36	Y36 Y34 Y37 Y39 Y40	N01 N02	
ETAV1220	200 x 105	8	3641	3641	3139	3358	3672	4865	3609	3296	+315
ETAV1221	220 x 105	8	3800	3800	3276	3506	3833	5078	3768	3440	+315
ETAV1222	240 x 105	10	3985	3985	3435	3676	4019	5325	3951	3607	+315
ETAV1223	260 x 105	10	4170	4170	3594	3846	4205	5571	4134	3774	+315
ETAV1224	280 x 105	12	4354	4354	3754	4016	4392	5818	4317	3941	+315
ETAV1225	220 x 125	8	3835	-	3306	3538	-	-	3802	3472	+315
ETAV1226	240 x 125	10	4020	-	3465	3708	-	-	3985	3639	+315
ETAV1227	260 x 125	10	4204	-	3625	3878	-	-	4168	3806	+315
ETAV1228	280 x 125	12	4389	-	3784	4048	-	-	4351	3973	+315

	A x B										
ETAV1229	300 x 105	12	4934	4934	4305	4580	4973	6465	4894	4502	+415
ETAV1230	300 x 125	12	4978	-	4344	4622	-	-	4939	4542	+415
ETAV1231	360 x 125	14	-	-	4809	5119	-	-	-	5030	+415
ETAV1232	400 x 125	16	-	-	5329	5675	-	-	-	5576	+415

maggiorazione per esterno riparato solo per surcharge for sheltered outdoor only for majoration pour ext rieur prot g  juste pour Zuschlag f r drau en gesch tzt nur f r aumento para exterior reparado solo para

- S05 D01 L03 L08 C35
S06 D02 L06 L10 C36
S07 D03 L11
S08

accessori disponibili a pg.195
accessories available on pg.195
accessoires disponibles pg.195
erh ltliches Zubeh r auf pg.195
accesorios disponibles en pg.195

disponibili riduzioni a misura
tailor-made reduction available
disponibles r ductions sur mesure
Verkleinerung nach Kundenwunsch
disponibles reducciones a medida

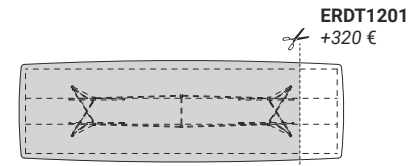
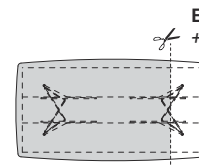

- acciaio verniciato/painted steel/acier peint
lackierter Stahl/acero pintado
- C12** bianco/white
 - C21** seta/silk
 - C23** corda/ecru
 - C30** ghisa/cast-iron
 - C14** antracite/anthracite
 - C08** nero/black
 - C18** verde/green
 - C26** corten/corten
 - C29** bronzo/bronze
 - C37** rame/copper
 - C38** titanio/titanium

- ceramica/ceramic/c eramique
Keramik/cer mico
- S05** antracite/anthracite
 - S06** nero/black
 - S07** porfido/porfido
 - S08** cardoso/cardoso

- HPL POLARIS®
- L03** bianco/white
 - L10** grigio chiaro/light grey
 - L11** grigio scuro/dark grey
- HPL FENIX®
- L08** grigio Londra/London grey
 - L06** nero/black

- HPL+ cemento/concrete/ciment
zement/cemento
- D01** bianco calce/lime white
 - D02** grigio Portland/Portland grey
 - D03** nero/black
- HPL+ metallo/metal/m tal/Metall/metal
- C31** ottone/brass
 - C32** ottone scuro/dark brass
 - C35** inox/inox
 - C36** inox scuro/dark inox

- HPL+ legno/wood/bois/Holz/madera
- Y36** rovere/oak
 - Y34** noce/walnut
 - Y37** rovere affumicato/smoked oak
 - Y39** frassino nero/black ash
 - Y40** frassino argilla/clay ash
- HPL+ ecotouch
- N01** sabbia/sand
 - N02** basalto/basalt

TAVOLI AFFIANCATI RETTANGOLARI / RECTANGULAR SIDE TABLES / TABLES ASSOCI ES RECTANGULAIRES
NEBENEINANDER GESTELLTE RECHTECKIGE TISCHE / MESAS RECTANGULARES PARA COLOCAR UNAS AL LADO DE LAS OTRAS

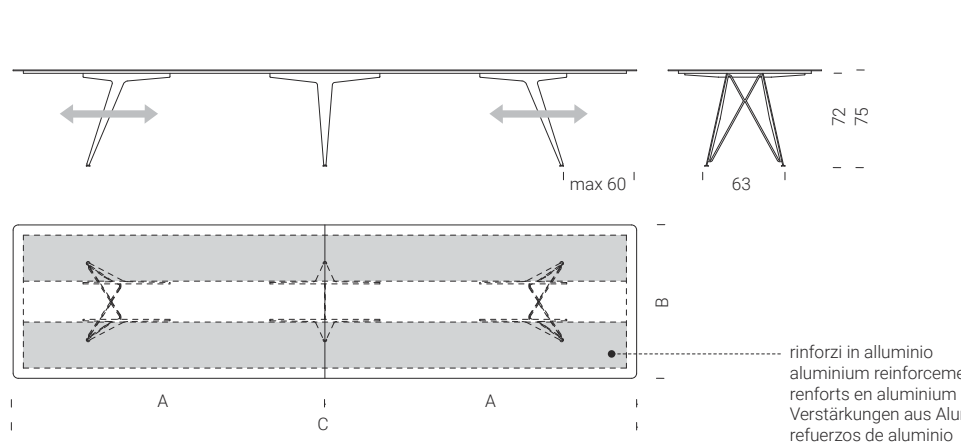

	C x B	16	S05 S06	S07 S08	L03 L06	L08 L10 L11	D01 D02 D03	C31 C32 C35 C36	Y36 Y34 Y37 Y39 Y40	N01 N02	+465
ETAV1233	440 x 100	16	6000	6000	5172	5534	6052	8017	5948	5431	+465
ETAV1234	480 x 100	18	6369	6369	5491	5875	6424	8510	6314	5765	+465
ETAV1235	520 x 100	18	6738	6738	5809	6215	6796	9003	6680	6099	+465
ETAV1236	440 x 120	16	6040	-	5207	5571	6092	8070	5988	5467	+465
ETAV1237	480 x 120	18	6409	-	5525	5912	6464	8564	6354	5801	+465
ETAV1238	520 x 120	18	6778	-	5843	6252	6836	9057	6720	6135	+465

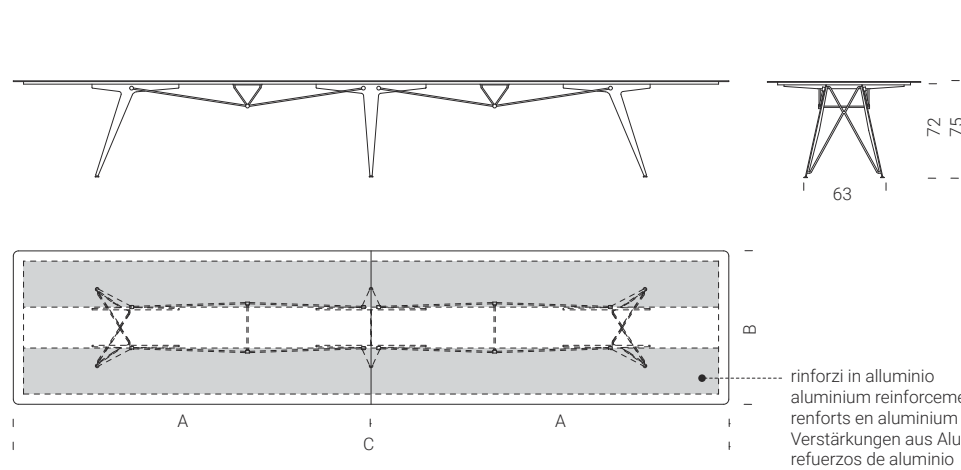

	C x B	20	S05 S06	S07 S08	L03 L06	L08 L10 L11	D01 D02 D03	C31 C32 C35 C36	Y36 Y34 Y37 Y39 Y40	N01 N02	+615
ETAV1239	560 x 100	20	7867	7867	6887	7316	7928	10257	7806	7193	+615
ETAV1240	600 x 100	22	8702	8702	7607	8086	8771	11372	8634	7949	+615
ETAV1241	560 x 120	20	7907	-	6921	7353	7969	10310	7845	7229	+615
ETAV1242	600 x 120	22	8747	-	7645	8127	8816	11432	8678	7989	+615

maggiorazione per esterno riparato solo per surcharge for sheltered outdoor only for majoration pour ext rieur prot g  juste pour Zuschlag f r drau en gesch tzt nur f r aumento para exterior reparado solo para

- S05 D01 L03 L08 C35**
- S06 D02 L06 L10 C36**
- S07 D03 L11**
- S08**

accessori disponibili a pg.195
accessoires available on pg.195
accessoires disponibles pg.195
erh ltliches Zubeh r auf pg.195
accesorios disponibles en pg.195

disponibili riduzioni a misura
tailor-made reduction available
disponibles r ductions sur mesure
Verkleinerung nach Kundenwunsch
disponibles reducciones a medida

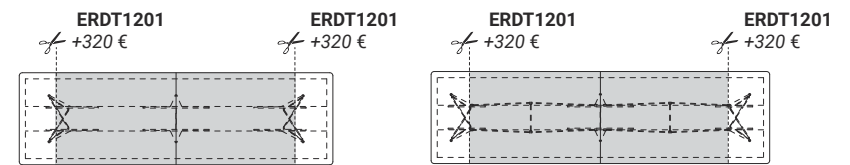

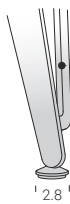

acciaio verniciato/painted steel/acier peint
lackierter Stahl/acero pintado

- C12 bianco/white
- C21 seta/silk
- C23 corda/ecru
- C30 ghisa/cast-iron
- C14 antracite/anthracite
- C08 nero/black
- C18 verde/green
- C26 corten/corten
- C29 bronzo/bronze
- C37 rame/copper
- C38 titanio/titanium

ceramica/ceramic/c eramique
Keramik/cer amico

- S05 antracite/anthracite
- S06 nero/black
- S07 porfido/porfido
- S08 cardoso/cardoso

0.6

- HPL POLARIS®
- L03 bianco/white
- L10 grigio chiaro/light grey
- L11 grigio scuro/dark grey

HPL FENIX®

- L08 grigio Londra/London grey
- L06 nero/black

0.7

- HPL+ cemento/concrete/ciment
zement/cemento
- D01 bianco calce/lime white
- D02 grigio Portland/Portland grey
- D03 nero/black

HPL+ metallo/metal/m etal/Metall/metal

- C31 ottone/brass
- C32 ottone scuro/dark brass
- C35 inox/inox
- C36 inox scuro/dark inox

0.7

- HPL+ legno/wood/bois/Holz/madera
- Y36 rovere/oak
- Y34 noce/walnut
- Y37 rovere affumicato/smoked oak
- Y39 frassino nero/black ash
- Y40 frassino argilla/clay ash

HPL+ ecotouch

- N01 sabbia/sand
- N02 basalto/basalt

TAVOLI AFFIANCATI A BOTTE / BARREL VAULT SIDE TABLES / TABLES TONNEAU ASSOCI ES
NEBENEINANDER GESTELLTE WEINFASS-TISCHE / MESAS DE BARRIL PARA COLOCAR UNAS AL LADO DE LAS OTRAS

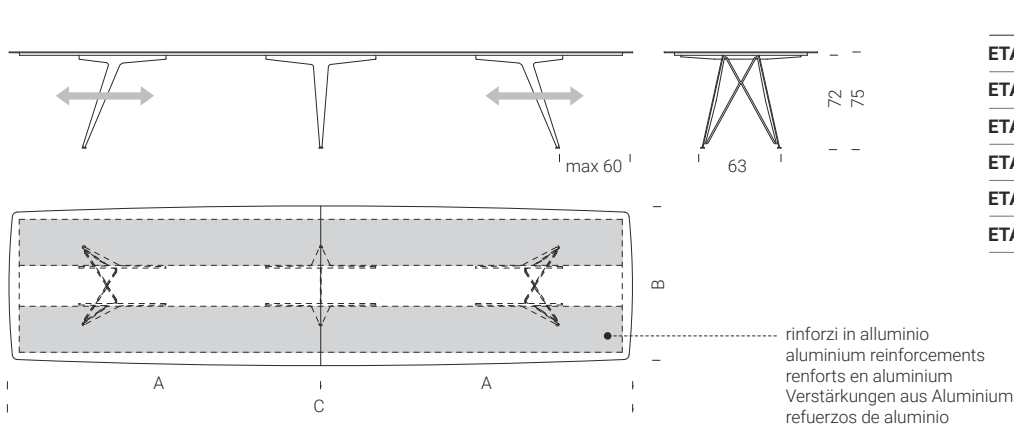

	C x B	16	18	18	16	18	18	18	18	18	18	18	18	18
		16	18	18	16	18	18	18	18	18	18	18	18	18
		S05 S06	S07 S08	L03 L06	L08 L10 L11	D01 D02 D03	C31 C32 C35 C36	Y36 Y34 Y37 Y39 Y40	N01 N02					
ETAV1243	440 x 105	6000	6000	5172	5534	6052	8017	5948	5431	+465				
ETAV1244	480 x 105	6369	6369	5491	5875	6424	8510	6314	5765	+465				
ETAV1245	520 x 105	6738	6738	5809	6215	6796	9003	6680	6099	+465				
ETAV1246	440 x 125	6070	-	5233	5599	-	-	6017	5494	+465				
ETAV1247	480 x 125	6439	-	5551	5939	-	-	6383	5828	+465				
ETAV1248	520 x 125	6808	-	5869	6280	-	-	6749	6162	+465				

rinforzi in alluminio
aluminium reinforcements
renforts en aluminium
Verst rkungen aus Aluminium
refuerzos de aluminio

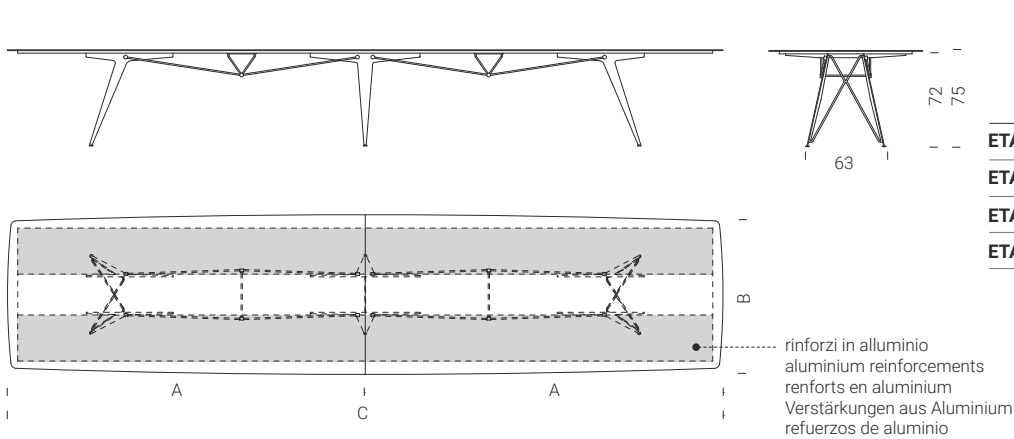

	C x B	20	22	20	22	20	22	20	22	20	22	20	22
		20	22	20	22	20	22	20	22	20	22	20	22
		S05 S06	S07 S08	L03 L06	L08 L10 L11	D01 D02 D03	C31 C32 C35 C36	Y36 Y34 Y37 Y39 Y40	N01 N02				
ETAV1249	560 x 105	7867	7867	6887	7316	7928	10257	7806	7193	+615			
ETAV1250	600 x 105	8702	8702	7607	8086	8771	11372	8634	7949	+615			
ETAV1251	560 x 125	7937	-	6947	7380	-	-	7875	7256	+615			
ETAV1252	600 x 125	8780	-	7674	8158	-	-	8711	8020	+615			

rinforzi in alluminio
aluminium reinforcements
renforts en aluminium
Verst rkungen aus Aluminium
refuerzos de aluminio

maggiorazione per esterno riparato solo per surcharge for sheltered outdoor only for majoration pour ext rieur prot g e juste pour Zuschlag f r drau en gesch tzt nur f r aumento para exterior reparado solo para

- S05 D01 L03 L08 C35
- S06 D02 L06 L10 C36
- S07 D03 L11
- S08

accessori disponibili a pg.195
accessories available on pg.195
accessoires disponibles pg.195
erh ltliches Zubeh r auf pg.195
accesorios disponibles en pg.195

disponibili riduzioni a misura
tailor-made reduction available
disponibles r ductions sur mesure
Verkleinerung nach Kundenwunsch
disponibles reducciones a medida

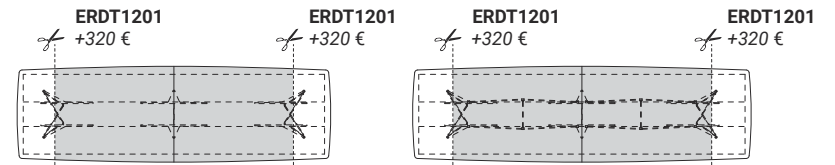



ceramica/ceramic/c eramique
Keramik/cer amico

S05 antracite/anthracite
S06 nero/black
S07 porfido/porfido
S08 cardoso/cardoso



HPL POLARIS®

L03 bianco/white
L10 grigio chiaro/light grey
L11 grigio scuro/dark grey

HPL FENIX®

L08 grigio Londra/London grey
L06 nero/black



HPL+ cemento/concrete/ciment
zement/cemento

D01 bianco calce/lime white
D02 grigio Portland/Portland grey
D03 nero/black

HPL+ metallo/metal/m etal/Metall/metal

C31 ottone/brass
C32 ottone scuro/dark brass
C35 inox/inox
C36 inox scuro/dark inox

PASSACAVO / CABLE GLAND / PASSE-C ABLE / KABELDURCHLASS / PASACABLES

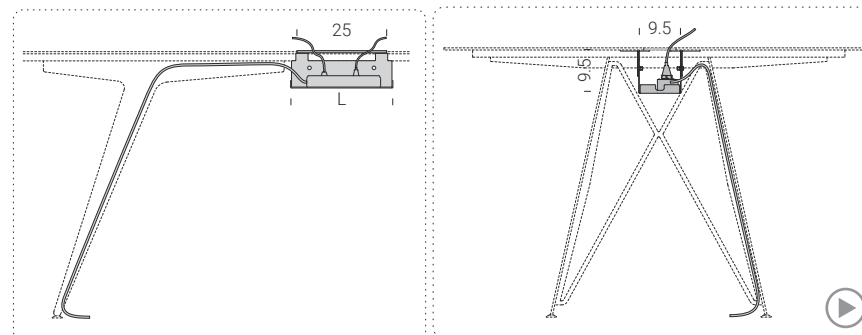
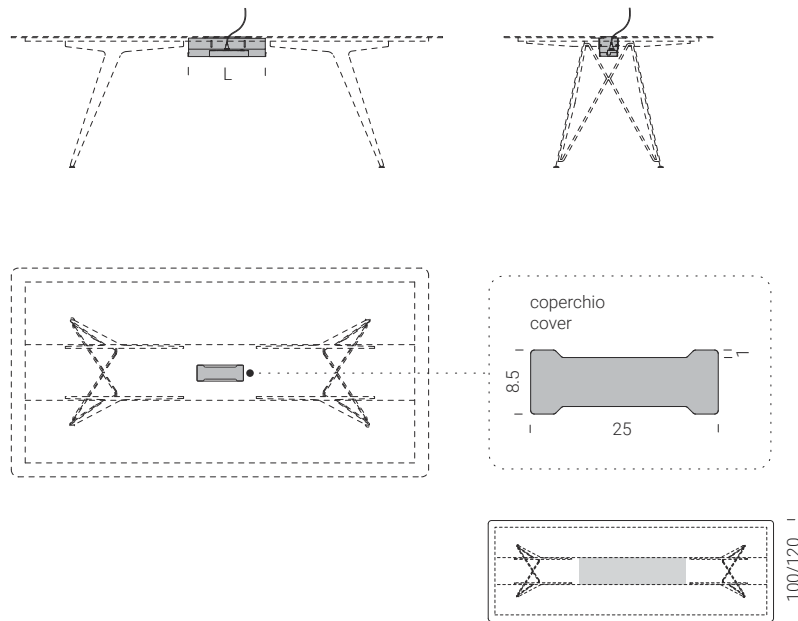

cesto in acciaio e copertura magnetica nelle finiture del tavolo.
steel basket and magnetic cover in the table finishings.
panier en acier et couvercle magn etique dans les m emes finitions que la table.
Stahlkorb und Magnetabdeckung in der Tischausf uhrung.
cesto de acero y cubierta magn etica en los acabados de la mesa.

Il passacavo pu  essere posizionato esclusivamente nelle aree evidenziate.
the cable tidy can be placed only in the highlighted areas
le passe-c ables peut  tre plac  que dans le domaines mis en  vidence
das Kabeldurchf hrung kann nur in den hervorgehobenen Bereichen angeordnet werden
el pasacables se puede colocar s lo en las  reas resaltadas



Il passacavo non pu  essere inserito nei tavoli in HPL profondit  90.
The cable duct cannot be inserted in HPL tables with a depth of 90.
Le passe-c ables ne peut pas  tre ins r  dans les tables en HPL profondeur 90.
Die Kabeldurchf hrung kann nicht in Tischen aus HPL Tiefe 90 eingesetzt werden.
el pasacables no puede insertarse en las mesas de HPL profundidad 90.

VASSOI / TRAYS / PLATEAUX / TABLETS / BANDEJAS

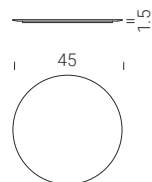

S05 **L08** **D01** **C31**
S06 **L10** **D02** **C32**
S07 **L03** **D03** **C35**
S08 **L06** **L11** **D03** **C36**

SACC0007	45 x 1.5	190	165	180	205	245
-----------------	----------	-----	-----	-----	-----	-----

vedi catalogo a pg.172 / refer to catalogue pg.172
Voir catalogue pg. 172 / siehe Katalog auf pg.172
v ase pg.172 del cat logo

	L	
SACC0003	28	185
SACC0004	40	205

vedi catalogo a pg.156
refer to catalogue pg.156
Voir catalogue pg. 156
siehe Katalog auf pg.156
v ase pg.156 del cat logo

T12



Caratteristiche costruttive
Construction characteristics
Caract ristiques de construction
Konstruktionsmerkmale
Caracteristicas constructivas

MR. HYDE



MR. HYDE È UNA COLLEZIONE DI TAVOLI CHE NASCONDONO NELLA PARTE SOTTOSTANTE UNO O PIÙ DISCHI CON DIAMETRO 48-54 CM. I DISCHI POSSONO ESSERE ESTRATTI RUOTANDOLI, AUMENTANDO LA SUPERFICIE DISPONIBILE DEL TAVOLINO. I TOP MR.HYDE ED I DISCHI ESTRAIBILI SONO IN HPL SPESSORE 6 MM CHE NELLO SVILUPPO DEL PERIMETRO VIENE RIDOTTO TRAMITE FRESATURA AD UNO SPESSORE DI SOLI 3 MM.

Mr. Hyde is a collection of tables with one or more hidden discs of diameters between 48 and 54 cm. The discs can be extracted by turning them, thus increasing the available space on the table. The mr.hyde tops and extractable discs are in 6 mm HPL, milled around the edge to a thickness of just 3 mm.

Mr. Hyde est une collection de tables de café qui cachent dans la partie sous-jacente un ou plusieurs disques avec un diamètre de 48-54 cm. Les disques peuvent être extraits en les faisant tourner, en augmentant ainsi la superficie disponible de la table basse. Les plateaux mr.hyde et les disques extractibles sont réalisés en HPL de 6 mm d'épaisseur, qui est réduite par fraisage le long du périmètre à une épaisseur de seulement 3 mm.

Mr. Hyde ist eine Kollektion von Tables, die auf der Unterseite eine oder mehrere runde Platten mit einem Durchmesser von 48-54 cm verbergen. Die runden Platten können herausgedreht werden und vergrößern so die Ablagefläche des Tisches. Die HPL-Tischplatte und die runden Platten sind aus 6 mm starkem HPL gefertigt, der Rand ist dagegen auf eine Stärke von 3 mm.

Mr. Hyde es una colección de tables que esconden en la parte inferior uno o varios discos, con un diámetro de 48-54 cm. Los discos pueden extraerse girándolos, aumentando la superficie disponible de la mesita. Los sobres de mr.hyde y los discos extraíbles son de hpl, de 6 mm de espesor, que en el desarrollo del perímetro se reduce a través de fresado a un espesor solo de 3 mm.

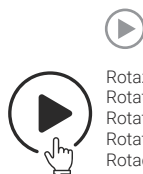
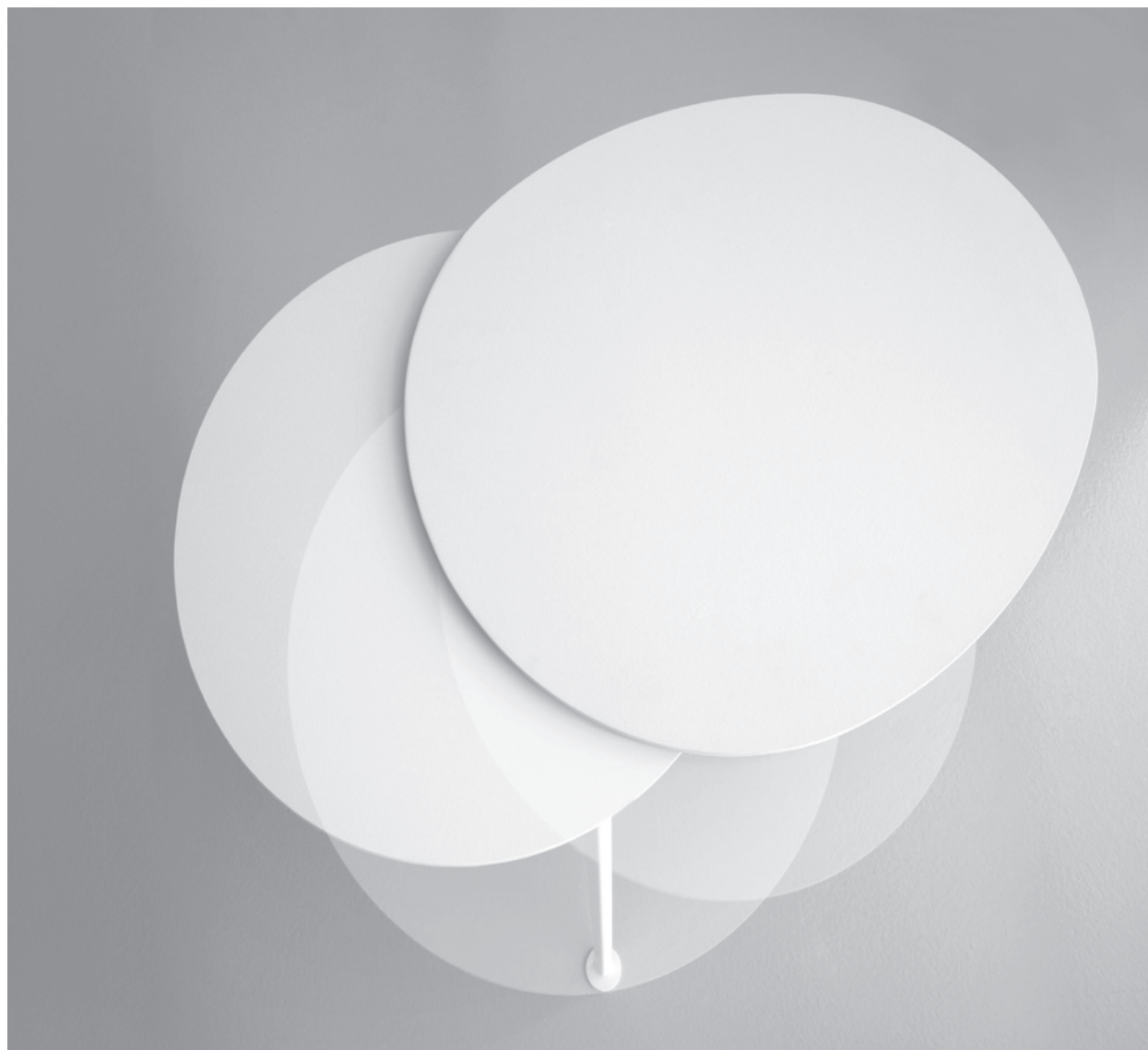

Rotazione allunghe
Rotation of extensions
Rotation des rallonges
Rotation verlängerungsstücke
Rotación de extensiones

acciaio verniciato/painted steel/acier peint
lackierter Stahl/acero pintado

- C12** bianco/white
- C21** seta/silk
- C23** corda/ecru
- C30** ghisa/cast-iron
- C14** antracite/anthracite
- C08** nero/black
- C18** verde/green
- C26** corten/corten
- C29** bronzo/bronze
- C37** rame/copper
- C38** titanio/titanium

0,6 0,3

- HPL POLARIS®**
- L03** bianco/white
 - L10** grigio chiaro/light grey
 - L11** grigio scuro/dark grey
- HPL FENIX®**
- L08** grigio Londra/London grey
 - L06** nero/black

0,7 0,3

- HPL+ cemento/concrete/ciment
zement/cemento**
- D01** bianco calce/lime white
 - D02** grigio Portland/Portland grey
 - D03** nero/black
- HPL+ metallo/metal/métal/Metall/metal**
- C31** ottone/brass
 - C32** ottone scuro/dark brass
 - C35** inox/inox
 - C36** inox scuro/dark inox

0,7 0,3

- HPL+ legno/wood/bois/Holz/madera**
- Y36** rovere/oak
 - Y34** noce/walnut
 - Y37** rovere affumicato/smoked oak
 - Y39** frassino nero/black ash
 - Y40** frassino argilla/clay ash
- HPL+ ecotouch**
- N01** sabbia/sand
 - N02** basalto/basalt

**TAVOLI E TAVOLINI / TABLES AND COFFEE TABLES / TABLES ET TABLES BASSES
TISCHE UND COUCHTISCHE / MESAS Y MESAS BAJAS**

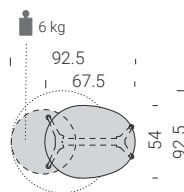
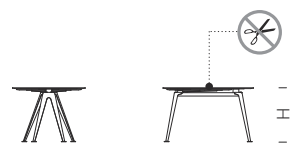

HTAV0001

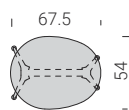

HTAV0008

	A x B	H		L03 L06	L08 L10 L11	D01 D02 D03	C31 C32 C35 C36	Y36 Y34 Y37 Y39 Y40	N01 N02
HTAV0001	54 x 67.5	40.5	-	766	820	896	1188	881	805
HTAV0008	54 x 67.5	40.5	-	556	595	650	861	639	584

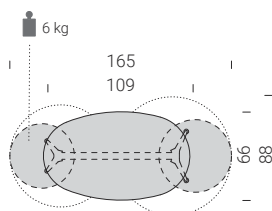
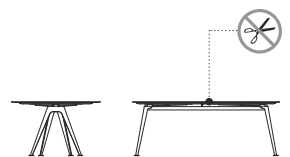

HTAV0002
HTAV0004

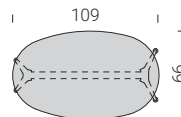

HTAV0009
HTAV0006

	A x B	H		L03 L06	L08 L10 L11	D01 D02 D03	C31 C32 C35 C36	Y36 Y34 Y37 Y39 Y40	N01 N02
HTAV0002	66 x 109	40.5	-	1204	1288	1408	1866	1384	1264
HTAV0009	66 x 109	40.5	-	772	826	903	1197	888	811
HTAV0004	66 x 109	75	2	1342	1436	1570	2080	1543	1409
HTAV0006	66 x 109	75	2	910	974	1065	1410	1046	955

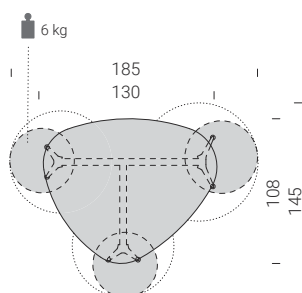
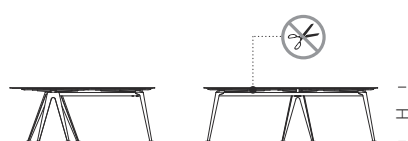

HTAV0003
HTAV0005

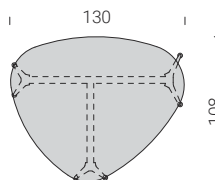

HTAV0007
HTAV0010

	A x B	H		L03 L06	L08 L10 L11	D01 D02 D03	C31 C32 C35 C36	Y36 Y34 Y37 Y39 Y40	N01 N02
HTAV0003	108 x 130	40.5	-	1787	1912	2091	2770	2055	1877
HTAV0010	108 x 130	40.5	-	1143	1223	1338	1772	1315	1200
HTAV0005	108 x 130	75	4	1989	2129	2327	3083	2288	2089
HTAV0007	108 x 130	75	4	1349	1443	1578	2090	1551	1416

*
senza dischi
without discs
sans disques
ohne Platten
sin discos

DÉCO

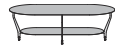

UNA COLLEZIONE DI TAVOLINI CHE SI ISPIRA AD UNO STILE CHE HA INFLUENZATO L'ARCHITETTURA ED IL DESIGN NEGLI ANNI 30. LE NUOVE TECNOLOGIE PER LA LAVORAZIONE DEI METALLI E LE ALTE PERFORMANCE DEI MATERIALI IMPIEGATI, HANNO CONSENTITO DI REINTERPRETARE UNO STILE DALLE FORME CLASSICHE IN GEOMETRIE CONTEMPORANEE

This is a collection of coffee tables inspired by a style that influenced both the fields of architecture and design during the 1930s. The new metalworking technologies and the high-performing materials used, have made it possible to re-interpret a style with classical forms in contemporary profiles.

Une collection de tables basses qui s'inspire d'un style qui a influencé l'architecture et le design dans les années 30. Les nouvelles technologies pour l'usinage des métaux et les performances élevées des matériaux employés ont permis de réinterpréter un style aux formes classiques en géométries contemporaines.

Eine Kollektion von Tischen, die sich am Art Déco inspiriert, einer Stilrichtung, die die Architektur und das Design der 1930er Jahre beeinflusst hat. Innovative Technologien bei der Metallbearbeitung und leistungsfähige Materialien erlauben die Neuinterpretation eines von klassischen Formen geprägten Stils, die mit zeitgenössischen Konturen überzeugt.

Una colección de mesitas inspirada en el estilo que predominó en la arquitectura y el diseño de los años 30. Las nuevas tecnologías para el procesamiento de metales y las altas prestaciones de los materiales utilizados, permitieron reinterpretar un estilo caracterizado por formas clásicas, creando geometrías contemporáneas.



acciaio verniciato/painted steel/acier peint
lackierter Stahl/acero pintado

C12 bianco/white
C21 seta/silk
C23 corda/ecru
C30 ghisa/cast-iron
C14 antracite/anthracite
C08 nero/black
C18 verde/green
C26 corten/corten
C29 bronzo/bronze
C37 rame/copper
C38 titanio/titanium

marmo/marble/marbre
Marmor/mármol

Z01 bianco Carrara/white Carrara
Z02 nero Marquìña/black Marquìña

ceramica/ceramic/c eramique
Keramik/cer mico

S05 antracite/anthracite
S06 nero/black
S07 porfido/porfido
S08 cardoso/cardoso

HPL POLARIS®

L03 bianco/white
L10 grigio chiaro/light grey
L11 grigio scuro/dark grey

HPL FENIX®

L08 grigio Londra/London grey
L06 nero/black

HPL+ cemento/concrete/ciment
zement/cemento

D01 bianco calce/lime white
D02 grigio Portland/Portland grey
D03 nero/black

HPL+ metallo/metal/m tal/Metall/metal

C31 ottone/brass
C32 ottone scuro/dark brass
C35 inox/inox
C36 inox scuro/dark inox

HPL+ legno/wood/bois/Holz/madera

Y36 rovere/oak
Y34 noce/walnut
Y37 rovere affumicato/smoked oak
Y39 frassino nero/black ash
Y40 frassino argilla/clay ash

HPL+ ecotouch

N01 sabbia/sand
N02 basalto/basalt

TAVOLI BASSI/ COFFEE TABLES / TABLES BASSES / COUCHTISCHE / MESAS BAJAS

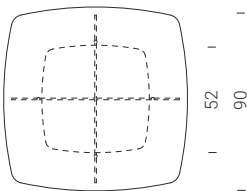
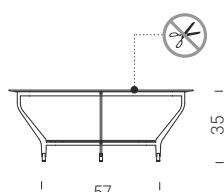
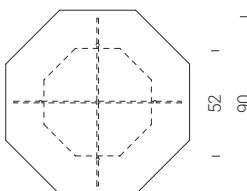
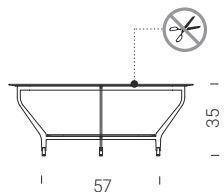
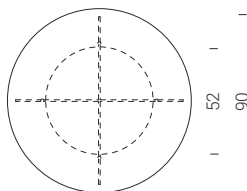
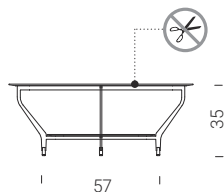

	∅	Z01 Z02	S05 S06 S07 S08	L03 L06	L08 L10 L11	D01 D02 D03	C31 C32 C35 C36	Y36 Y34 Y37 Y39 Y40	N01 N02		
QTAV0002	90	3024	1480	1276	1365	1492	1977	1467	1339	846	+114

	A x B	Z01 Z02	S05 S06 S07 S08	L03 L06	L08 L10 L11	D01 D02 D03	C31 C32 C35 C36	Y36 Y34 Y37 Y39 Y40	N01 N02		
QTAV0003	90 x 90	2980	1480	1276	1365	1492	1977	1467	1339	846	+114

	A x B	Z01 Z02	S05 S06 S07 S08	L03 L06	L08 L10 L11	D01 D02 D03	C31 C32 C35 C36	Y36 Y34 Y37 Y39 Y40	N01 N02		
QTAV0004	90 x 90	2980	1480	1276	1365	1492	1977	1467	1339	846	+114

maggiorazione per esterno riparato solo per surcharge for sheltered outdoor only for majoration pour ext rieur prot g e juste pour Zuschlag f r drau en gesch tzt nur f r aumento para exterior reparado solo para

S05 D01 L03 L08 C35
S06 D02 L06 L10 C36
S07 D03 L11
S08

solo telaio (info pg.101)
frame only (info on pg.101)
seulement b ti (info pg.101)
Ausschlie lich Rahmen (Info pg.101)
solo marco (informaci n pg.101)

accessori disponibili a pg.201
accessories available on pg.201
accessoires disponibles pg.201
erh ltliches Zubeh r auf pg.201
accesorios disponibles en pg.201

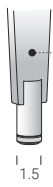

acciaio verniciato/painted steel/acier peint
lackierter Stahl/acero pintado

- C12** bianco/white
- C21** seta/silk
- C23** corda/ecru
- C30** ghisa/cast-iron
- C14** antracite/anthracite
- C08** nero/black
- C18** verde/green
- C26** corten/corten
- C29** bronzo/bronze
- C37** rame/copper
- C38** titanio/titanium



marmo/marble/marbre
Marmor/mármol

- Z01** bianco Carrara/white Carrara
- Z02** nero Marquiña/black Marquiña



ceramica/ceramic/c ramique
Keramik/cer mico

- S05** antracite/anthracite
- S06** nero/black
- S07** porfido/porfido
- S08** cardoso/cardoso



HPL POLARIS®

- L03** bianco/white
- L10** grigio chiaro/light grey
- L11** grigio scuro/dark grey

HPL FENIX®

- L08** grigio Londra/London grey
- L06** nero/black



HPL+ cemento/concrete/ciment
zement/cemento

- D01** bianco calce/lime white
- D02** grigio Portland/Portland grey
- D03** nero/black

HPL+ metallo/metal/m tal/Metall/metal

- C31** ottone/brass
- C32** ottone scuro/dark brass
- C35** inox/inox
- C36** inox scuro/dark inox



HPL+ legno/wood/bois/Holz/madera

- Y36** rovere/oak
- Y34** noce/walnut
- Y37** rovere affumicato/smoked oak
- Y39** frassino nero/black ash
- Y40** frassino argilla/clay ash

HPL+ ecotouch

- N01** sabbia/sand
- N02** basalto/basalt

TAVOLI BASSI/ COFFEE TABLES / TABLES BASSES / COUCHTISCHE / MESAS BAJAS

D CO

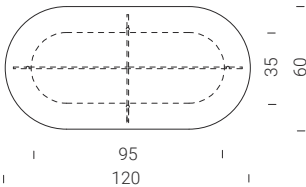
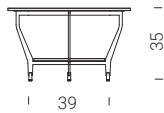
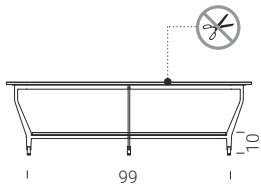
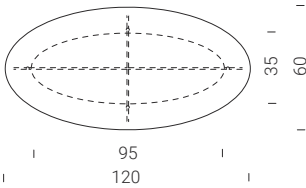
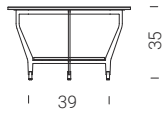
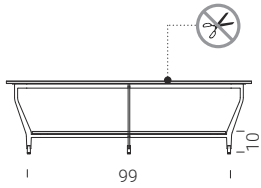

A x B	Z01	S05	L03	L08	D01	C31	Y36	N01	827	+114	
	Z02	S06				L10	D02				C32
QTAV0006	120 x 60	2980	1447	1248	1335	1460	1934	1435	1310	827	+114

A x B	Z01	S05	L03	L08	D01	C31	Y36	N01	832	+114	
	Z02	S06				L10	D02				C32
QTAV0005	120 x 60	2980	1454	1254	1342	1467	1944	1442	1317	832	+114



maggiorazione per esterno riparato solo per surcharge for sheltered outdoor only for majoration pour ext rieur prot g  juste pour Zuschlag f r drau en gesch tzt nur f r aumento para exterior reparado solo para

- S05** **D01** **L03** **L08** **C35**
- S06** **D02** **L06** **L10** **C36**
- S07** **D03** **L11**
- S08**



solo telaio (info pg.101)
frame only (info on pg.101)
seulement b ti (info pg.101)
Ausschlie lich Rahmen (Info pg.101)
solo marco (informaci n pg.101)



accessori disponibili a pg.201
accessories available on pg.201
accessoires disponibles pg.201
erh ltliches Zubeh r auf pg.201
accesorios disponibles en pg.201

- acciaio verniciato/painted steel/acier peint
lackierter Stahl/acero pintado
- C12** bianco/white
 - C21** seta/silk
 - C23** corda/ecru
 - C30** ghisa/cast-iron
 - C14** antracite/anthracite
 - C08** nero/black
 - C18** verde/green
 - C26** corten/corten
 - C29** bronzo/bronze
 - C37** rame/copper
 - C38** titanio/titanium

- marmo/marble/marbre
Marmor/mármol
- Z01** bianco Carrara/white Carrara
 - Z02** nero Marquìña/black Marquìña

- ceramica/ceramic/c eramique
Keramik/cer amico
- S05** antracite/anthracite
 - S06** nero/black
 - S07** porfido/porfido
 - S08** cardoso/cardoso

- HPL POLARIS®
- L03** bianco/white
 - L10** grigio chiaro/light grey
 - L11** grigio scuro/dark grey
- HPL FENIX®
- L08** grigio Londra/London grey
 - L06** nero/black

- HPL+ cemento/concrete/ciment
zement/cemento
- D01** bianco calce/lime white
 - D02** grigio Portland/Portland grey
 - D03** nero/black
- HPL+ metallo/metal/m etal/Metall/metal
- C31** ottone/brass
 - C32** ottone scuro/dark brass
 - C35** inox/inox
 - C36** inox scuro/dark inox

- HPL+ legno/wood/bois/Holz/madera
- Y36** rovere/oak
 - Y34** noce/walnut
 - Y37** rovere affumicato/smoked oak
 - Y39** frassino nero/black ash
 - Y40** frassino argilla/clay ash
- HPL+ ecotouch
- N01** sabbia/sand
 - N02** basalto/basalt

TAVOLI BASSI/ COFFEE TABLES / TABLES BASSES / COUCHTISCHE / MESAS BAJAS

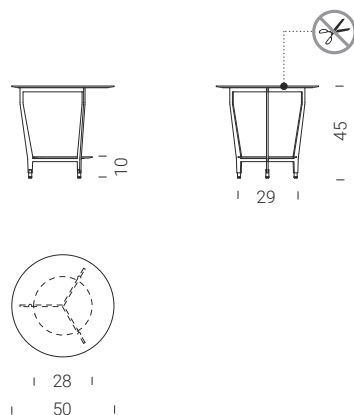

	∅	Z01 Z02	S05 S06 S07 S08	L03 L06	L08 L10 L11	D01 D02 D03	C31 C32 C35 C36	Y36 Y34 Y37 Y39 Y40	N01 N02		
QTAV0001	50	1962	663	571	611	669	886	657	600	379	+114

VASSOI / TRAYS / PLATEAUX / TABLETS / BANDEJAS

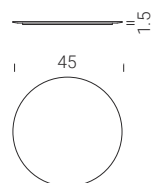

		S05 S06 S07 S08	L03 L06	L08 L10 L11	D01 D02 D03	C31 C32 C35 C36
SACC0007	45 x 1.5	190	165	180	205	245

vedi catalogo a pg.172 / refer to catalogue pg.172
Voir catalogue pg. 172 / siehe Katalog auf pg.172
véase pg.172 del cat logo

maggiorazione per esterno riparato solo per surcharge for sheltered outdoor only for majoration pour ext rieur prot g  juste pour Zuschlag f r drau en gesch tzt nur f r aumento para exterior reparado solo para

S05 D01 L03 L08 C35
S06 D02 L06 L10 C36
S07 D03 L11
S08

solo telaio (info pg.101)
frame only (info on pg.101)
seulement b ti (info pg.101)
Ausschlie lich Rahmen (Info pg.101)
solo marco (informaci n pg.101)

SEATING FEATURES



LE NUOVE COLLEZIONI DI SEDUTE EXTENDO ADOTTANO SOLUZIONI INNOVATIVE E PRATICHE.
LE PAGINE SEGUENTI NE RIASSUMONO LE PRINCIPALI CARATTERISTICHE TECNICHE COSTRUTTIVE DELLE STRUTTURE E DEI RIVESTIMENTI.

The new extendo seat collections propose innovative and practical solutions. The following pages summarise the main technical and construction characteristics of the structures and upholsteries.

Les nouvelles collections de sièges extendo adoptent des solutions innovantes et pratiques. Les principales caractéristiques techniques et constructives des structures et revêtements sont résumées dans les pages suivantes.

Die neuen Sitz-Kollektionen Extendo wenden innovative und praktische Lösungen an. Die folgenden Seiten fassen die wichtigsten technischen Baumerkmale der Strukturen und Polsterungen zusammen.

Las nuevas colecciones de sillas extendo adoptan soluciones innovadoras y prácticas. En las siguientes páginas se resumen las principales características técnicas y constructivas de las estructuras y revestimientos.

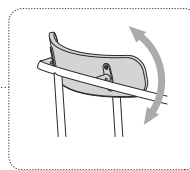
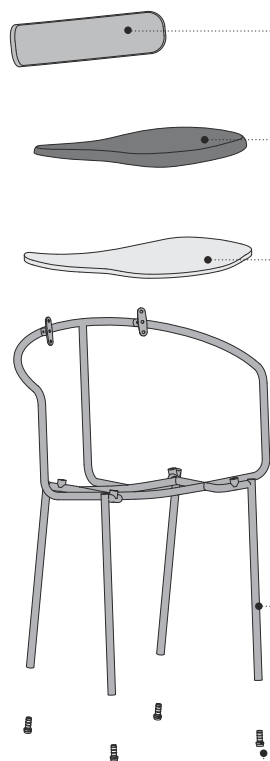

SCHIENALI / BACKRESTS / DOSSIERS / RÜCKENLEHNEN / RESPALDOS

Il meccanismo degli schienali adattivi attraverso un'oscillazione controllata segue e sostiene il movimento della schiena. Sono disponibili in essenza, rivestiti in cuoio o tessuto, (sempre sfoderabili).

The mechanism of the adjustable backrests with controlled rocking follows and supports the movement of the back. They are available in wood, upholstered in leather or fabric (always removable).

Le mécanisme des dossiers adaptatifs par oscillation contrôlée suit et soutient le mouvement du dossier. Ils sont disponibles en bois, recouverts de cuir ou de tissu (toujours déhoussables).

Der Mechanismus der adaptiven Rückenlehnen folgt der Bewegung des Rückens und unterstützt sie über eine kontrollierte Schwingung. Sie sind aus Holz mit (immer abnehmbaren Polsterzeug) aus Leder oder Gewebe verfügbar.

Respaldos: El mecanismo de los respaldos adaptativos mediante oscilación controlada sigue y sostiene el movimiento del respaldo. Están disponibles en madera, revestidos en piel o tejido, (siempre desenfundables).

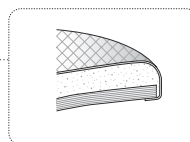

CUSCINI / CUSHIONS / COUSSINS / KISSEN / COJINES

Il cuscino è un accessorio da abbinare alle sedute in essenza.

The cushion is an accessory to match with the wooden seats.

Le coussin est un accessoire à combiner avec les sièges en bois.

Das Kissen ist ein mit den Sitzflächen aus Holz kombinierbares Zubehör.

El cojín es un complemento a combinar con los asientos de madera.

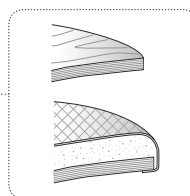

SEDUTE / SEATS / SIÈGES / SITZFLÄCHEN / ASIENTOS

Le sedute sono disponibili in essenza, con rivestimento in cuoio e in 3 categorie di tessuto. I rivestimenti in tessuto sono disponibili in versione sfoderabile o fissa.

The seats are available in wood, with leather upholstery and 3 types of fabric. The fabric upholsteries are available in removable and non-removable versions.

Les sièges sont disponibles en bois, avec revêtement en cuir et en 3 catégories de tissu. Les housses en tissu sont disponibles en version amovible ou fixe.

Die Sitzflächen sind aus Holz und mit Polsterzeug aus Leder oder aus 3 Gewebekategorien verfügbar. Die Polsterungen aus Gewebe sind in der Ausführung abnehmbares Polsterzeug oder fest verfügbar.

Los asientos están disponibles en madera, tapizados en piel y en 3 categorías de tejido. Las fundas de tela están disponibles en versión desenfundable o fija.

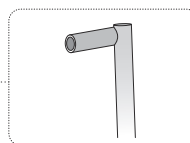

TELAJ / FRAMES / CADRES / GESTELLE / ESTRUCTURA

il telaio è in acciaio verniciato a polveri disponibile in 11 colorazioni.

the frame in powder coated steel is available in 11 colours.

le cadre est en acier thermolaqué disponible en 11 couleurs.

Das pulverlackierte Stahl-Gestell ist in 11 Farben verfügbar.

la estructura es de acero con recubrimiento de polvo disponible en 11 colores.

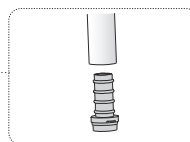

PIEDINI / FEET / PIEDS / FÜÙE / PIES

I piedini hanno un terminale intercambiabile per adattarsi a tutte le tipologie di pavimento.

The feet have an interchangeable base to adapt to all types of flooring.

Les pieds ont une extrémité interchangeable pour s'adapter à tous les types de sols.

Die FüÙe verfügen über ein austauschbares Endstück, um sich allen Fußbodentypen anzupassen.

Los pies tienen un extremo intercambiable para adaptarse a todo tipo de suelos.

MATERIALI E FINITURE / MATERIALS AND FINISHES / MATÉRIAUX ET FINITIONS / MATERIALIEN UND AUSFÜHRUNGEN / MATERIALES Y ACABADOS

LEGNO MASSICCIO / SOLID WOOD

- T01 rovere/oak
T02 noce/walnut
T05 rovere nero/black oak

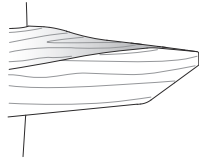

La superficie in legno viene trattata con uno strato di vernice all'acqua. Le tavole in legno massiccio sono sottoposte ad un processo di essiccazione per garantirne la stabilità nel tempo.

The wooden surface is treated with a layer of water-based paint. The solid wood boards are subjected to a drying process to ensure their stability over time.

ESSENZE / WOODS

- Y36 rovere/oak
Y34 noce/walnut
Y37 rovere affumicato/smoked oak

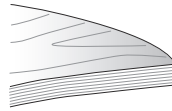

- Y40 frassino argilla/clay ash
Y39 frassino nero/black ash

Il supporto in multistrato di faggio utilizzato per sedute e schienali garantisce solidità e stabilità nel tempo. L'impiallacciatura è in essenza naturale di produzione italiana.

The multi-layer beechwood support for the seats and backs guarantee solidity and stability over time. The veneer is in natural essence of Italian origin.

CUOIO / COW-HIDE

- F01 tabacco/tobacco
F02 nero/black

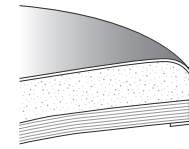

Il cuoio toscano con concia al vegetale "in fossa" è trattato con grassi vegetali, utilizziamo lo spessore di 2mm per la collezione Viking K, mentre per tutti gli altri rivestimenti lo spessore impiegato è di 1mm.

Tuscan leather with "in pit" vegetable tanning is treated with vegetable fat; we use a thickness of 2 mm for the Viking K collection while for all the other upholsteries the thickness used is 1 mm.

POLIESTERE / POLYESTER

- JA01 perla/pearl
JA02 avorio/ivory
JA03 fango/mud
JA04 salvia/sage
JA05 olivia/olive
JA06 cipria/powder pink

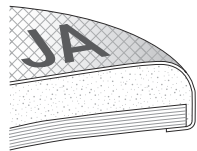

ottima resistenza all'usura impermeabile e resistente alle macchie mantiene i colori nel tempo resistente al lavaggio in acqua a 30° asciugatura rapida ottima stabilità dimensionale ingalciabile 100% anallergico traspirante

composizione/composition
100% poliestere/polyester
peso/weight
400 gr/mq
BSI
50.000 cicli/cycles

excellent resistance to wear waterproof and stain resistant maintains its colour over time washable in water at 30° quick drying excellent dimensional stability crease-resistant 100% hypoallergenic breathable

MISTO COTONE / MIXED COTTON

- JB01 natur/natur
JB02 ecrù/ecru
JB03 grigio/grey
JB04 cenere/ash
JB05 platino/platinum
JB06 antracite/anthracite

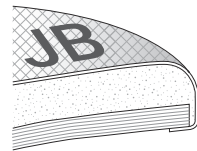

buona resistenza all'usura trattamento antimacchia in filo mantiene i colori nel tempo resistente al lavaggio in acqua a 30° asciugatura rapida buona stabilità dimensionale 100% antistatico e anallergico traspirante

composizione/composition
50% cotone/cotton
40% poliestere/polyester
10% poliacrilico/polyacrylic
peso/weight
430 gr/mq
BSI
40.000 cicli/cycles

good resistance to wear stain-resistance treatment in yarn maintains its colour over time washable in water at 30° quick drying good dimensional stability 100% antistatic and hypoallergenic breathable

MISTO LINO / MIXED LINEN

- JC01 fumo/smoke
JC02 cenere/ash
JC03 sacco/sack
JC04 terra/land
JC05 verde/green
JC06 rosa/pink

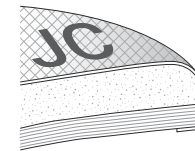

media resistenza all'usura 100% naturale mantiene i colori nel tempo consigliato lavaggio a mano in acqua fredda buona stabilità dimensionale 100% antistatico e anallergico massima traspirabilità

composizione/composition
60% lino/linen
40% viscosa/viscose
peso/weight
550 gr/mq
BSI
20.000 cicli/cycles

average resistance to wear 100% natural maintains its colour over time hand-washing in cold water recommended good dimensional stability 100% antistatic and hypoallergenic maximum breathability

RICAMBI / SPARE PARTS / PIÈCES DE RECHANGE / ERSATZTEILE / PIEZAS DE REPUESTO

RIVESTIMENTI PER SCHIENALE / FABRIC UPHOLSTERERS FOR BACKRESTS
HOUSES DE DOSSIERS EN TISSU / POLSTERUNGEN FÜR ERSATZTEILE
FUNDAS DE TELA PARA RESPALDOS

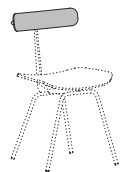

	JA-SF	JB-SF	JC-SF
VACS0003	71	75	81

(SF sfoderabile/removable)

disponibile per: VIKING | ECH3 | ECH4 | ECH5 | ECH6 | ECH7 | ECH8 | ECH9
available for:

RIVESTIMENTI PER SEDUTE / FABRIC UPHOLSTERERS FOR SEATS
HOUSES DE SIÈGE EN TISSU / POLSTERUNGEN FÜR SITZFLÄCHEN
FUNDAS DE TELA PARA ASIENTOS

VACS0002

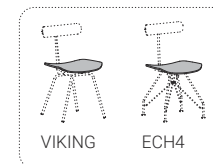

EACS00302

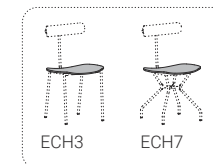

	JA-SF	JB-SF	JC-SF
VACS0002	99	103	119
EACS0302	105	109	125
EACS0501	105	109	125
EACS0801	105	109	125

(SF sfoderabile/removable)

EACS0501

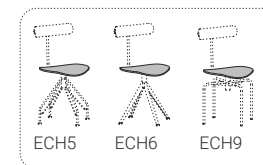

EACS0801

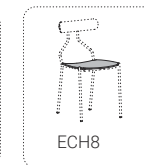

DANSKE C

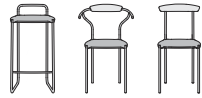

L'ACCIAIO E IL LEGNO VENGONO PLASMATI ESALTANDO LE LORO CARATTERISTICHE STRUTTURALI ED ESTETICHE. LE SINGOLE GEOMETRIE TRIDIMENSIONALI DI LEGNO E ACCIAIO SI COMPENETRANO IN UNICHE SUPERFICI. LE PARTI IN LEGNO MASSICCIO SONO PROTETTE CON VERNICE ALL'ACQUA OPACA ANTIGRAFFIO, MENTRE LE PARTI IN ACCIAIO SONO VERNICIATE A POLVERI.

Steel and wood are shaped to emphasise their structural and aesthetic characteristics. The individual, three-dimensional geometries of the wood and steel permeate in single surfaces. The solid wood parts are protected with matt, scratch-proof water-based varnish, while the steel parts are powder painted.

L'acier et le bois sont façonnés en exaltant leurs caractéristiques structurelles et esthétiques. Les différentes géométries tridimensionnelles du bois et de l'acier s'interpénètrent en surfaces uniques. Les parties en bois massif sont protégées avec du vernis à l'eau opaque résistant aux rayures, alors que les parties en acier sont vernies par poudres.

Stahl und Holz sind so geformt, dass ihre strukturellen und ästhetischen Eigenschaften unterstrichen werden. Die einzelnen, dreidimensionalen Formen von Holz und Stahl durchdringen zusammen zu einzigen Oberflächen. Die Teile aus Massivholz sind mit einer Schicht aus mattem und kratzfesten Wasserlack geschützt und die Teile aus Stahl sind pulverlackiert.

El acero y la madera se modelan exaltando sus características estructurales y estéticas. Las geometrías tridimensionales individuales de la madera y el acero se compenetran en superficies únicas. Las piezas de madera maciza están protegidas con barniz mate al agua resistente a los arañazos, mientras que las piezas de acero están tratadas con barniz en polvo.



Piedini intercambiabili
Interchangeable feet
Pieds interchangeables
Austauschbare Füße
Pies intercambiables



Caratteristiche costruttive
Construction characteristics
Caractéristiques de construction
Konstruktionsmerkmale
Características constructivas

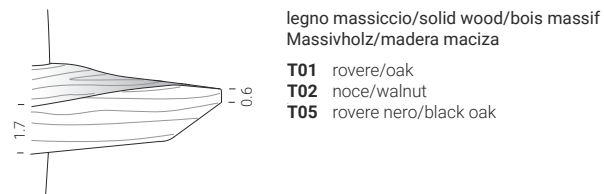
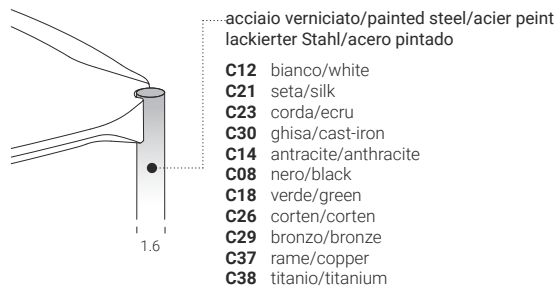

SEDIA C1 / CHAIR C1 / CHAISE C1
STUHL C1 / SILLA C1

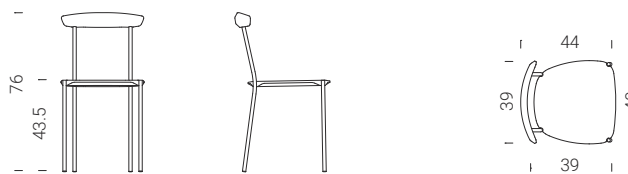

	T01	T02	T05
ISED0001	491	583	495

SEDIA CON BRACCIOLI C2 / CHAIR WITH ARMRESTS C2 / CHAISE AVEC ACCOUDOIRS C2
STUHL MIT ARMLEHNE C2 / SILLA CON REPOSABRAZOS C2



	T01	T02	T05
ISED0002	528	639	538

SGABELLO C3 / STOOL C3 / TABOURET C3
HOCKER C3 / TABURETE C3

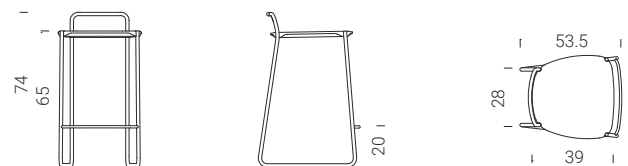

	T01	T02	T05
ISED0003	452	528	461

VIKING



LA LAMA IN ACCIAIO CHE RICORDA IL PROFILO DI CHIGLIA DELLE NAVI VICHINGHE È LA SPINA DORSALE DI TUTTE LE SEDUTE CHE FANNO PARTE DELLA COLLEZIONE. SU DI ESSA SI INNESTANO IL FONDELLO LO SCHIENALE E GLI APPOGGI A TERRA. IL TELAIO È IN ACCIAIO, MENTRE I COMPONENTI DI SEDUTA E SCHIENALE SONO DISPONIBILI IN MULTISTRATO O CUOIO.

The steel blade recalling the contour of the keel of Viking ships is the backbone of all the chairs belonging to this collection. The chair seat, the backrest and the chair legs are inserted onto this. The chair frame is made of steel, while the seat and backrest are available in either plywood or leather.

La lame en acier qui rappelle le profil de la quille des navires vikings est l'épine dorsale de toutes les assises qui font partie de la collection. C'est sur elle que s'enclenchent le fond, le dossier et les appuis au sol. Le châssis est en acier alors que les composants de l'assise et du dossier sont disponibles en multicouche ou en cuir.

Ein Stahlprofil, das an den Rumpf der Wikingerschiffe erinnert, stellt das Rückgrat aller Stühle dieser Kollektion dar, an dem die Sitzfläche, die Rückenlehne und die Bodenstützen befestigt sind. Der Rahmen ist aus Stahl gefertigt, während die Sitzflächen und die Lehnen in Sperrholz oder Leder erhältlich sind.

La cuchilla de acero que recuerda el perfil de la quilla de los barcos vikingos, es la espina dorsal de todos los asientos que forman parte de la colección. Sobre ella, se ensamblan el fondo, el respaldo y los apoyos en el suelo. El bastidor es de acero, mientras que los componentes del asiento y el respaldo, están disponibles en madera estratificada o cuero.



Schienale adattivo
Adjustable backrest
Dossier adaptatif
Adaptive Rückenlehne
Respaldo adaptable



ADAPTIVE
CHAIR BACKREST
registered community
design



Sfoderabile
Removable upholstery
Déhoussable
Abnehmbares Polsterzeug
Cubierta desmontable



Piedini intercambiabili
Interchangeable feet
Pieds interchangeables
Austauschbare Füße
Pies intercambiables



Caratteristiche costruttive
Construction characteristics
Caractéristiques de construction
Konstruktionsmerkmale
Características constructivas



VIKING K



VIKING W

acciaio verniciato
painted steel
acier peint
lackierter Stahl
acero pintado

C12 bianco/white
C21 seta/silk
C23 corda/ecru
C30 ghisa/cast-iron
C14 antracite/anthracite
C08 nero/black
C18 verde/green
C26 corten/corten
C29 bronzo/bronze
C37 rame/copper
C38 titanio/titanium

viking K

cuoio/cow-hide/cuir
Kernleder/cuero

F01 tabacco/tobacco
F02 nero/black

viking W

essenze/woods/bois
Holzes/maderas

Y36 rovere/oak
Y34 noce/walnut
Y37 rovere affumicato/smoked oak
Y39 frassino nero/black ash
Y40 frassino argilla/clay ash

cuoio/cow-hide/cuir
Kernleder/cuero

F01 tabacco/tobacco
F02 nero/black

tessuto/fabric/tissu
Stoff/tela

poliestere
polyester

JA01 perla/perl
JA02 avorio/ivory
JA03 fango/mud
JA04 salvia/sage
JA05 olivia/olive
JA06 cipria/powder pink

JA-SF sfoderabile
removable
(pg.211)

misto cotone
mixed cotton

JB01 natur/natur
JB02 ecru/ecru
JB03 grigio/grey
JB04 cenere/ash
JB05 platino/platinum
JB06 antracite/anthracite

JB-SF sfoderabile
removable
(pg.211)

misto lino
mixed linen

JC01 fumo/smoke
JC02 cenere/ash
JC03 sacco/sack
JC04 terra/land
JC05 verde/green
JC06 rosa/pink

JC-SF sfoderabile
removable
(pg.211)

tessuto fornito
fabric provided

JX

JX-SF sfoderabile
removable
(pg.211)

SEDIA VIKING K / CHAIR VIKING K / CHAISE VIKING K / STUHL VIKING K / SILLA VIKING K

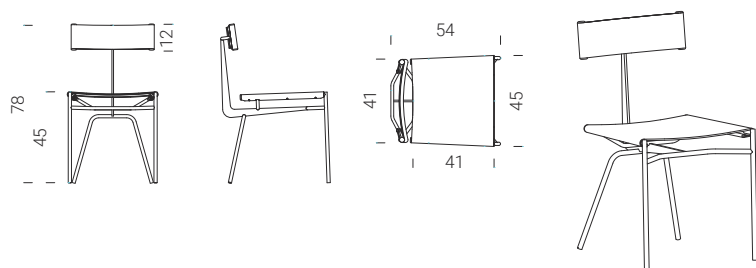

	F
VSED0004	781

SEDIA VIKING W / CHAIR VIKING W / CHAISE VIKING W / STUHL VIKING W / SILLA VIKING W

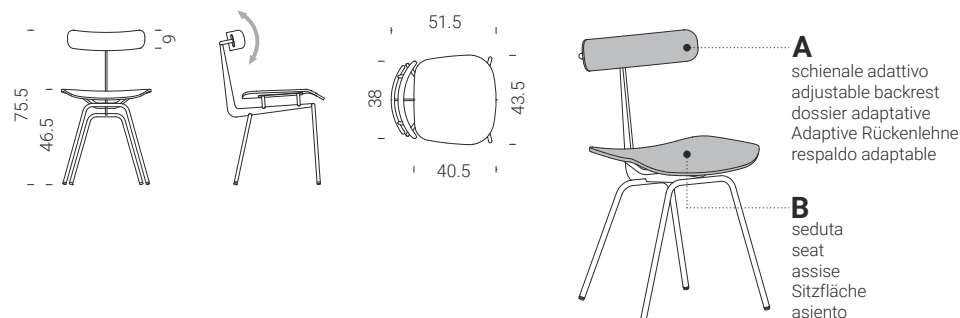

VSED0001	A										
	Y36	Y34	Y37	Y39	Y40	JA-SF	JB-SF	JC-SF	JX-SF	F	
B	Y36	403	-	-	-	-	465	469	474	-	463
	Y34	-	417	-	-	-	472	476	482	-	470
	Y37	-	-	423	-	-	478	482	487	-	476
	Y39	-	-	-	414	-	470	474	480	-	468
	Y40	-	-	-	-	413	469	473	479	-	467
	JA	345	352	352	352	352	407	-	-	-	-
	JB	358	364	364	364	364	-	423	-	-	-
	JC	365	370	370	370	370	-	-	436	-	-
	JX	345	352	352	352	352	-	-	-	407	-
	JA-SF	487	494	494	494	494	549	-	-	-	-
JB-SF	498	504	504	504	504	-	564	-	-	-	
JC-SF	510	516	516	516	516	-	-	581	-	-	
F	512	518	518	518	518	-	-	-	-	571	

CUSCINO / CUSHION / COUSSIN / KISSEN / COJÍN

il cuscino va abbinato ai fondelli in essenza Y36/Y34/Y37/Y39/Y40
the cushion must be matched with the wooden seats in Y36/Y34/Y37/Y39/Y40 essences
le coussin doit être associé aux dossiers en bois Y36/Y34/Y37/Y39/Y40
Das Kissen muss an die Sitzflächen aus Holz Y36/Y34/Y37/Y39/Y40 angepasst werden
El cojín va combinado con los respaldos de madera Y36/Y34/Y37/Y39/Y40

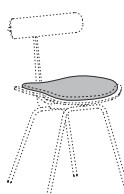

	JA	JB	JC	JX	F
VACS0001	115	123	135	115	173

il cuscino non è ordinabile successivamente
the cushion cannot be ordered later
le coussin ne peut pas être commandé successivement
Das Kissen kann nicht im Nachhinein bestellt werden
El cojín no se puede encargar con posterioridad

ECH3



CARATTERIZZATA DA UN'AMPIA E COMODA SEDUTA OVALE E DAL MECCANISMO DI SCHIENALE ADATTIVO, LA COLLEZIONE RAPPRESENTA LA SINTESI TRA RIGORE GEOMETRICO E RICERCA DI MASSIMO CONFORT. PER FONDELLO E SCHIENALE SONO DISPONIBILI RIVESTIMENTI IN TESSUTO SFODERABILE CHE NE CONSENTONO IL LAVAGGIO O IL RICAMBIO.

Characterized by a large and comfortable oval seat and backrest adjustment mechanism, the collection represents the synthesis between geometric rigour and the search for maximum comfort. For the seating and backrest there is removable fabric upholstery to allow it to be cleaned or changed.

Caractérisée par une assise ovale large et confortable et un mécanisme de dossier adaptatif, la collection est une synthèse entre la rigueur géométrique et la recherche du meilleur confort. Des housses en tissu amovibles sont disponibles pour le fond et le dossier, afin de permettre leur lavage et leur remplacement

Gekennzeichnet durch eine breite und bequeme ovale Sitzfläche und durch den adaptiven Rückenlehnen-Mechanismus stellt die Kollektion die Synthese zwischen der geometrischen Strenge und die Suche nach dem höchsten Komfort dar. Für Sitzfläche und Rückenlehne sind Überzüge mit abnehmbaren Polsterzeug verfügbar, die deren Waschen und Austausch ermöglichen.

Caracterizada por un amplio y cómodo asiento ovalado y un mecanismo de respaldo adaptable, la colección representa la síntesis del rigor geométrico y la búsqueda del máximo confort. Hay fundas de tela extraíbles para el asiento y el respaldo, que permiten lavarlas o sustituirlas.



Schienale adattivo
Adjustable backrest
Dossier adaptatif
Adaptive Rückenlehne
Respaldo adaptable



ADAPTIVE
CHAIR BACKREST
registered community
design



Sfoderabile
Removable upholstery
Déhoussable
Abnehmbares Polsterzeug
Cubierta desmontable



Piedini intercambiabili
Interchangeable feet
Pieds interchangeables
Austauschbare FüÙe
Pies intercambiables



Caratteristiche costruttive
Construction characteristics
Caractéristiques de construction
Konstruktionsmerkmale
Características constructivas



acciaio verniciato/painted steel
acier peint/lackierter Stahl
acero pintado

C12 bianco/white
C21 seta/silk
C23 corda/ecru
C30 ghisa/cast-iron
C14 antracite/anthracite
C08 nero/black
C18 verde/green
C26 corten/corten
C29 bronzo/bronze
C37 rame/copper
C38 titanio/titanium

essenze/woods/bois
Holzes/maderas

Y36 rovere/oak
Y34 noce/walnut
Y37 rovere affumicato/smoked oak
Y39 frassino nero/black ash
Y40 frassino argilla/clay ash

cuoio/cow-hide/cuir
Kernleder/cuero

F01 tabacco/tobacco
F02 nero/black

tessuto/fabric/tissu/Stoff/tela

poliestere
polyester

JA01 perla/perl
JA02 avorio/ivory
JA03 fango/mud
JA04 salvia/sage
JA05 olivia/olive
JA06 cipria/powder pink

misto cotone
mixed cotton

JB01 natur/natur
JB02 ecru/ecru
JB03 grigio/grey
JB04 cenere/ash
JB05 platino/platinum
JB06 antracite/anthracite

misto lino
mixed linen

JC01 fumo/smoke
JC02 cenere/ash
JC03 sacco/sack
JC04 terra/land
JC05 verde/green
JC06 rosa/pink

tessuto fornito
fabric provided

JX

JA-SF sfoderabile
removable
(pg.211)

JB-SF sfoderabile
removable
(pg.211)

JC-SF sfoderabile
removable
(pg.211)

JX-SF sfoderabile
removable
(pg.211)

SEDIA ECH3 / CHAIR ECH3 / CHAISE ECH3 / STUHL ECH3 / SILLA ECH3

A schienale adattivo
adjustable backrest
dossier adaptative
Adaptive Rückenlehne
respaldo adaptable

B seduta
seat
assise
Sitzfläche
asiento

ESED0301	A									
	Y36	Y34	Y37	Y39	Y40	JA-SF	JB-SF	JC-SF	JX-SF	F
Y36	388	-	-	-	-	450	453	459	-	447
Y34	-	402	-	-	-	457	461	467	-	455
Y37	-	-	408	-	-	463	466	472	-	460
Y39	-	-	-	399	-	455	459	464	-	453
Y40	-	-	-	-	398	454	458	463	-	452
JA	335	341	341	341	341	397	-	-	-	-
JB	342	348	348	348	348	-	407	-	-	-
JC	351	358	358	358	358	-	-	422	-	-
JX	335	341	341	341	341	-	-	-	397	-
JA-SF	476	482	482	482	482	537	-	-	-	-
JB-SF	479	486	486	486	486	-	545	-	-	-
JC-SF	494	499	499	499	499	-	-	565	-	-
F	497	502	502	502	502	-	-	-	-	556

**SEDIA CON BRACCIOLI ECH3 / CHAIR WITH ARMRESTS ECH3 / CHAISE AVEC ACCOUDOIRS ECH3
STUHL MIT ARMLEHNE ECH3 / SILLA CON REPOSABRAZOS ECH3**

A schienale adattivo
adjustable backrest
dossier adaptative
Adaptive Rückenlehne
respaldo adaptable

B seduta
seat
assise
Sitzfläche
asiento

ESED0302	A									
	Y36	Y34	Y37	Y39	Y40	JA-SF	JB-SF	JC-SF	JX-SF	F
Y36	407	-	-	-	-	469	472	478	-	466
Y34	-	421	-	-	-	476	480	486	-	474
Y37	-	-	427	-	-	482	485	491	-	480
Y39	-	-	-	418	-	474	478	484	-	472
Y40	-	-	-	-	417	473	477	482	-	471
JA	352	359	359	359	359	413	-	-	-	-
JB	358	364	364	364	364	-	423	-	-	-
JC	368	374	374	374	374	-	-	439	-	-
JX	352	359	359	359	359	-	-	-	413	-
JA-SF	495	499	499	499	499	556	-	-	-	-
JB-SF	498	504	504	504	504	-	564	-	-	-
JC-SF	514	522	522	522	522	-	-	585	-	-
F	516	524	524	524	524	-	-	-	-	575

CUSCINO / CUSHION / COUSSIN / KISSEN / COJÍN

il cuscino va abbinato ai fondelli in essenza Y36/Y34/Y37/Y39/Y40
the cushion must be matched with the wooden seats in Y36/Y34/Y37/Y39/Y40 essences
le coussin doit être associé aux dossiers en bois Y36/Y34/Y37/Y39/Y40
Das Kissen muss an die Sitzflächen aus Holz Y36/Y34/Y37/Y39/Y40 angepasst werden
El cojín va combinado con los respaldos de madera Y36/Y34/Y37/Y39/Y40

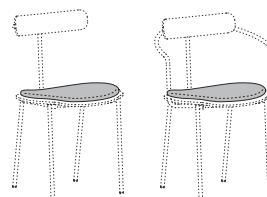

	JA	JB	JC	JX	F
EACS0301	120	128	140	120	178

il cuscino non è ordinabile successivamente
the cushion cannot be ordered later
le coussin ne peut pas être commandé successivement
Das Kissen kann nicht im Nachhinein bestellt werden
El cojín no se puede encargar con posterioridad

ECH4



IL DISEGNO LEGGERO DERIVA DAI PROFILI IN ACCIAIO A SEZIONE RIDOTTA CHE COSTITUISCONO IL TELAIO: 6/12 MM PER LE QUATTRO RAZZE CONTROVENTATE DA TIRANTI CHE NE IRRIGIDISCONO LA STRUTTURA. GLI SCHIENALI ADATTIVI E I FONDELLI IN TESSUTO SFODERABILE SONO DISPONIBILI NELLA VERSIONE CON O SENZA BRACCIOLI.

The light design is the result of the steel profiles with reduced cross-section that form the frame: 6/12 mm for the four spokes braced by tie-rods that stiffen the structure. The adjustable backrests and removable fabric upholstery seats of the chairs are available in versions with or without arms.

La légèreté du design passe par les profilés en acier à section réduite qui composent le cadre : 6/12 mm pour les quatre rayons renforcés par les tirants qui rigidifient la structure. Les dossiers et les fonds adaptatifs en tissu amovible sont disponibles dans la version avec ou sans accoudoirs.

Das leichte Design kommt aus den Stahlprofilen mit reduziertem Schnitt, die das Gestell bilden: 6/12 mm für die vier verspannten Speichen, die die Struktur versteifen. Die adaptiven Rückenlehnen und die Sitzflächen mit abnehmbarem Polsterzeug sind in der Version mit oder ohne Armlehnen verfügbar.

La ligereza se debe a los perfiles de acero de sección reducida que componen el bastidor: 6/12 mm para los cuatro radios arriostrados por tirantes que endurecen la estructura. Los respaldos adaptables y las fundas de tela extraíbles están disponibles con o sin reposabrazos



Schienale adattivo
Adjustable backrest
Dossier adaptatif
Adaptive Rückenlehne
Respaldo adaptable



ADAPTIVE
CHAIR BACKREST
registered community
design



Sfoderabile
Removable upholstery
Déhoussable
Abnehmbares Polsterzeug
Cubierta desmontable



Piedini intercambiabili
Interchangeable feet
Pieds interchangeables
Austauschbare Füße
Pies intercambiables



Caratteristiche costruttive
Construction characteristics
Caractéristiques de construction
Konstruktionsmerkmale
Características constructivas





acciaio verniciato/painted steel
acier peint/lackierter Stahl
acero pintado

- C12 bianco/white
- C21 seta/silk
- C23 corda/ecru
- C30 ghisa/cast-iron
- C14 antracite/anthracite
- C08 nero/black
- C18 verde/green
- C26 corten/corten
- C29 bronzo/bronze
- C37 rame/copper
- C38 titanio/titanium

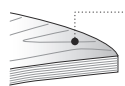

essenze/woods/bois
Holzes/maderas

- Y36 rovere/oak
- Y34 noce/walnut
- Y37 rovere affumicato/smoked oak
- Y39 frassino nero/black ash
- Y40 frassino argilla/clay ash

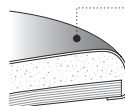

cuoio/cow-hide/cuir
Kernleder/cuero

- F01 tabacco/tobacco
- F02 nero/black

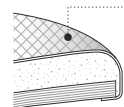

tessuto/fabric/tissu/Stoff/tela

poliestere
polyester

- JA01 perla/perl
- JA02 avorio/ivory
- JA03 fango/mud
- JA04 salvia/sage
- JA05 olivia/olive
- JA06 cipria/powder pink

JA-SF sfoderabile
removable
(pg.211)

misto cotone
mixed cotton

- JB01 natur/natur
- JB02 ecru/ecru
- JB03 grigio/grey
- JB04 cenere/ash
- JB05 platino/platinum
- JB06 antracite/anthracite

JB-SF sfoderabile
removable
(pg.211)

misto lino
mixed linen

- JC01 fumo/smoke
- JC02 cenere/ash
- JC03 sacco/sack
- JC04 terra/land
- JC05 verde/green
- JC06 rosa/pink

JC-SF sfoderabile
removable
(pg.211)

tessuto fornito
fabric provided

JX

JX-SF sfoderabile
removable
(pg.211)

SEDIA ECH4 / CHAIR ECH4 / CHAISE ECH4 / STUHL ECH4 / SILLA ECH4

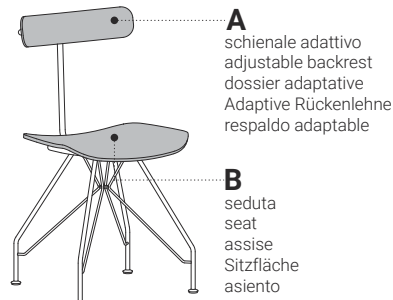
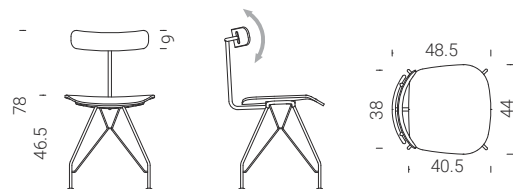

A
schienale adattivo
adjustable backrest
dossier adaptative
Adaptive Rückenlehne
respaldo adaptable

B
seduta
seat
assise
Sitzfläche
asiento

ESED0401		A									
		Y36	Y34	Y37	Y39	Y40	JA-SF	JB-SF	JC-SF	JX-SF	F
B	Y36	441	-	-	-	-	502	506	512	-	500
	Y34	-	454	-	-	-	510	514	519	-	508
	Y37	-	-	461	-	-	515	519	525	-	513
	Y39	-	-	-	451	-	508	511	517	-	505
	Y40	-	-	-	-	450	506	510	516	-	504
	JA	380	386	386	386	386	442	-	-	-	-
	JB	387	394	394	394	394	-	452	-	-	-
	JC	397	404	404	404	404	-	-	468	-	-
	JX	380	386	386	386	386	-	-	-	442	-
	JA-SF	528	534	534	534	534	590	-	-	-	-
	JB-SF	532	538	538	538	538	-	597	-	-	-
JC-SF	547	554	554	554	554	-	-	618	-	-	
F	549	556	556	556	556	-	-	-	-	609	

SEDIA CON BRACCIOLI ECH4 / CHAIR WITH ARMRESTS ECH4 / CHAISE AVEC ACCOUDOIRS ECH4 STUHL MIT ARMLEHNE ECH4 / SILLA CON REPOSABRAZOS ECH4

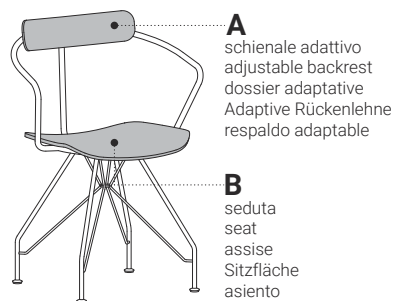
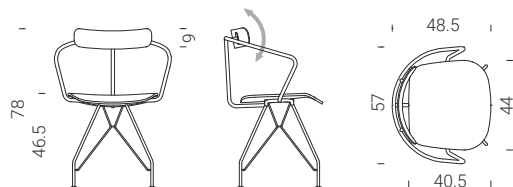

A
schienale adattivo
adjustable backrest
dossier adaptative
Adaptive Rückenlehne
respaldo adaptable

B
seduta
seat
assise
Sitzfläche
asiento

ESED0402		A									
		Y36	Y34	Y37	Y39	Y40	JA-SF	JB-SF	JC-SF	JX-SF	F
B	Y36	455	-	-	-	-	517	520	526	-	514
	Y34	-	468	-	-	-	524	528	534	-	522
	Y37	-	-	475	-	-	530	533	539	-	527
	Y39	-	-	-	466	-	522	526	531	-	520
	Y40	-	-	-	-	465	521	525	530	-	519
	JA	393	399	399	399	399	454	-	-	-	-
	JB	399	406	406	406	406	-	465	-	-	-
	JC	409	416	416	416	416	-	-	480	-	-
	JX	393	399	399	399	399	-	-	-	454	-
	JA-SF	543	548	548	548	548	604	-	-	-	-
	JB-SF	546	552	552	552	552	-	612	-	-	-
JC-SF	561	568	568	568	568	-	-	632	-	-	
F	564	569	569	569	569	-	-	-	-	623	

CUSCINO / CUSHION / COUSSIN / KISSEN / COJÍN

il cuscino va abbinato ai fondelli in essenza Y36/Y34/Y37/Y39/Y40
the cushion must be matched with the wooden seats in Y36/Y34/Y37/Y39/Y40 essences
le coussin doit être associé aux dossiers en bois Y36/Y34/Y37/Y39/Y40
Das Kissen muss an die Sitzflächen aus Holz Y36/Y34/Y37/Y39/Y40 angepasst werden
El cojín va combinado con los respaldos de madera Y36/Y34/Y37/Y39/Y40

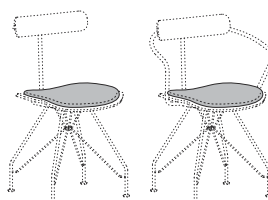

	JA	JB	JC	JX	F
VACS0001	115	123	135	115	173

il cuscino non è ordinabile successivamente
the cushion cannot be ordered later
le coussin ne peut pas être commandé successivement
Das Kissen kann nicht im Nachhinein bestellt werden
El cojín no se puede encargar con posterioridad

ECH5

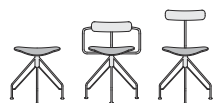

VARIANTE GIREVOLE DI ECH4, SI CARATTERIZZA PER LA STESSA STRUTTURA IN PROFILI D'ACCIAIO A SEZIONE RIDOTTA, NELLA QUALE LE QUATTRO RAZZE CONVERGONO NEL CONNETTORE GIREVOLE. LE SEDUTE CON BRACCIOLI HANNO UN'ALTEZZA CHE PERMETTE LA COMPLETA ROTAZIONE AL DI SOTTO DEL TOP TAVOLO. GLI SCHIENALI ADATTIVI SONO DISPONIBILI PER LE SEDIE CON O SENZA BRACCIOLI.

The revolving version of ECH4 has the same structure with small cross-section steel profiles, in which the four spokes converge in the revolving connector. The chairs with arms have a height that allows their full rotation under the table top. The adjustable backrests are available for the chairs with or without arms.

Variante pivotante du modèle ECH4, elle se caractérise par la même structure avec profilés en acier à section réduite, dans laquelle les quatre rayons convergent vers le connecteur pivotant. Les sièges avec accoudoirs ont une hauteur qui permet une rotation complète sous le plateau de la table. Des dossiers adaptatifs sont disponibles pour les chaises avec ou sans accoudoirs.

Drehbare Variante von ECH4, sie ist durch dieselbe Struktur aus Stahlprofilen mit reduziertem Schnitt gekennzeichnet, bei der die vier Speichen am drehbaren Verbindungselement zusammenlaufen. Die Sitzmöbel mit Armlehnen haben eine Höhe, die die komplette Drehung unterhalb der Tischplatte ermöglichen. Die adaptiven Rückenlehnen sind für die Stühle mit oder ohne Armlehnen verfügbar.

La variante giratoria de la ECH4, se caracteriza por la misma estructura de perfil de acero de sección reducida, en la que los cuatro radios convergen en el conector giratorio. Los asientos con reposabrazos tienen una altura que permite una rotación completa por debajo del tablero. Los respaldos adaptativos están disponibles para sillas con o sin reposabrazos.



Schienale adattivo
Adjustable backrest
Dossier adaptatif
Adaptive Rückenlehne
Respaldo adaptable



ADAPTIVE
CHAIR BACKREST
registered community
design



Sfoderabile
Removable upholstery
Déhoussable
Abnehmbares Polsterzeug
Cubierta desmontable



Piedini intercambiabili
Interchangeable feet
Pieds interchangeables
Austauschbare FüÙe
Pies intercambiables



Caratteristiche costruttive
Construction characteristics
Caractéristiques de construction
Konstruktionsmerkmale
Características constructivas





- acciaio verniciato/painted steel
acier peint/lackierter Stahl
acero pintado
- C12** bianco/white
 - C21** seta/silk
 - C23** corda/ecru
 - C30** ghisa/cast-iron
 - C14** antracite/anthracite
 - C08** nero/black
 - C18** verde/green
 - C26** corten/corten
 - C29** bronzo/bronze
 - C37** rame/copper
 - C38** titanio/titanium

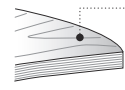

- essenze/woods/bois
Holzes/maderas
- Y36** rovere/oak
 - Y34** noce/walnut
 - Y37** rovere affumicato/smoked oak
 - Y39** frassino nero/black ash
 - Y40** frassino argilla/clay ash

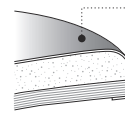

- cuoio/cow-hide/cuir
Kernleder/cuero
- F01** tabacco/tobacco
 - F02** nero/black

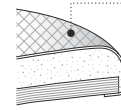

tessuto/fabric/tissu/Stoff/tela

- poliestere
polyester
- JA01** perla/perl
 - JA02** avorio/ivory
 - JA03** fango/mud
 - JA04** salvia/sage
 - JA05** olivia/olive
 - JA06** cipria/powder pink

misto cotone
mixed cotton

- JB01** natur/natur
- JB02** ecru/ecru
- JB03** grigio/grey
- JB04** cenere/ash
- JB05** platino/platinum
- JB06** antracite/anthracite

misto lino
mixed linen

- JC01** fumo/smoke
- JC02** cenere/ash
- JC03** sacco/sack
- JC04** terra/land
- JC05** verde/green
- JC06** rosa/pink

tessuto fornito
fabric provided

JX

JA-SF sfoderabile
removable
(pg.211)

JB-SF sfoderabile
removable
(pg.211)

JC-SF sfoderabile
removable
(pg.211)

JX-SF sfoderabile
removable
(pg.211)

SEDIA ECH5 / CHAIR ECH5 / CHAISE ECH5 / STUHL ECH5 / SILLA ECH5

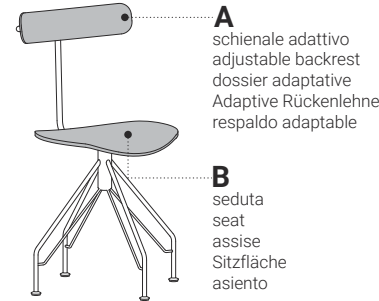
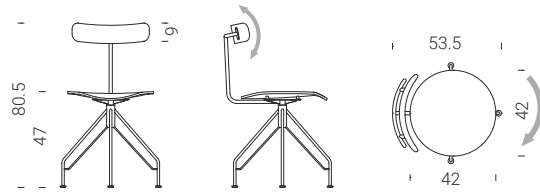

ESED0501		A									
		Y36	Y34	Y37	Y39	Y40	JA-SF	JB-SF	JC-SF	JX-SF	F
B	Y36	531	-	-	-	-	592	596	602	-	590
	Y34	-	544	-	-	-	600	604	609	-	598
	Y37	-	-	551	-	-	605	609	615	-	603
	Y39	-	-	-	542	-	598	602	607	-	596
	Y40	-	-	-	-	540	597	600	606	-	594
	JA	458	465	465	465	465	520	-	-	-	-
	JB	465	472	472	472	472	-	530	-	-	-
	JC	474	481	481	481	481	-	-	545	-	-
	JX	458	465	465	465	465	-	-	-	520	-
	JA-SF	618	625	625	625	625	680	-	-	-	-
	JB-SF	622	629	629	629	629	-	687	-	-	-
JC-SF	637	644	644	644	644	-	-	708	-	-	
F	640	647	647	647	647	-	-	-	-	699	

**SEDIA CON BRACCIOLI ECH5 / CHAIR WITH ARMRESTS ECH5 / CHAISE AVEC ACCOUDOIRS ECH5
STUHL MIT ARMLEHNE ECH5 / SILLA CON REPOSABRAZOS ECH5**

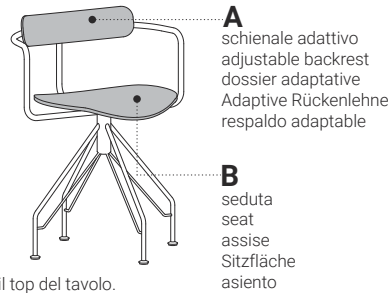
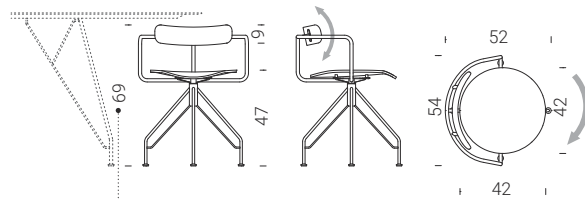

⚠ l'altezza dello schienale consente la rotazione della sedia sotto il top del tavolo.
the height of the backrest allows the chair to rotate below the table top.
la hauteur du dossier permet la rotation de la chaise sous le plateau de la table.
Die Höhe der Rückenlehne ermöglicht das Drehen des Stuhls unter der Tischplatte.
la altura del respaldo permite la rotación de la silla bajo la mesa.

ESED0502		A									
		Y36	Y34	Y37	Y39	Y40	JA-SF	JB-SF	JC-SF	JX-SF	F
B	Y36	541	-	-	-	-	603	607	612	-	601
	Y34	-	555	-	-	-	610	614	620	-	608
	Y37	-	-	561	-	-	616	620	625	-	614
	Y39	-	-	-	552	-	608	612	618	-	606
	Y40	-	-	-	-	551	607	611	617	-	605
	JA	467	474	474	474	474	529	-	-	-	-
	JB	474	479	479	479	479	-	539	-	-	-
	JC	483	490	490	490	490	-	-	554	-	-
	JX	467	474	474	474	474	-	-	-	529	-
	JA-SF	629	635	635	635	635	690	-	-	-	-
	JB-SF	633	640	640	640	640	-	698	-	-	-
JC-SF	648	655	655	655	655	-	-	719	-	-	
F	650	656	656	656	656	-	-	-	-	709	

SGABELLO ECH5 / STOOL ECH5 / TABOURET ECH5 / HOCKER ECH5 / TABURETE ECH5

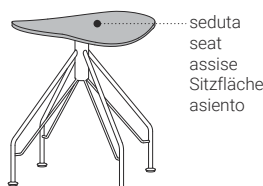

ESED0503	Y36	Y34	Y37	Y39	Y40			
	375	382	382	380	379			
ESED0503	JA	JB	JC	JX	JA-SF	JB-SF	JC-SF	F
	318	325	335	318	462	466	481	483

ⓘ ricambi a pg. 203 / spare parts on page 203 / pièces de rechange p.203
Ersatzteile auf S. 203 / Recambios en pág. 203

ECH6



IL DESIGN DELLA COLLEZIONE È DEFINITO DA QUATTRO RAZZE RASTREIMATE CHE CONVERGONO NEL CONNETTORE CENTRALE GIREVOLE. NE FANNO PARTE SGABELLI IN DUE ALTEZZE E SEDIE CON O SENZA BRACCIOLI CON SCHIENALE ADATTIVO. LE SEDUTE CON BRACCIOLI HANNO UN'ALTEZZA CHE PERMETTE LA COMPLETA ROTAZIONE AL DI SOTTO DEL TOP TAVOLO.

The design of the collection is defined by four tapered spokes that converge in the central revolving connector. The collection includes stools in two different heights and chairs with or without arms and adjustable backrest. The chairs with arms have a height that allows their full rotation under the table top.

Le design de la collection est défini par quatre rayons coniques qui convergent vers le connecteur pivotant central. La collection comprend des tabourets en deux hauteurs et des chaises, avec ou sans accoudoirs, à dossiers adaptatifs. Les sièges avec accoudoirs ont une hauteur qui permet une rotation complète sous le plateau de la table.

Das Design der Kollektion ist durch vier verjüngte Speichen bestimmt, die am zentralen drehbaren Verbindungselement zusammenlaufen. Dazu gehören Hocker in zwei Höhen und Stühle mit oder ohne Armlehnen mit adaptiver Rückenlehne. Die Sitzmöbel mit Armlehnen haben eine Höhe, die die komplette Drehung unterhalb der Tischplatte ermöglichen.

El diseño de la colección está definido por cuatro radios cónicos que convergen en el conector central giratorio. Incluye taburetes en dos alturas y sillas con o sin reposabrazos con respaldos adaptables. Las sillas con reposabrazos tienen una altura que les permite girar completamente bajo el tablero de la mesa.



Schienale adattivo
Adjustable backrest
Dossier adaptatif
Adaptive Rückenlehne
Respaldo adaptable



ADAPTIVE
CHAIR BACKREST
registered community
design



Sfoderabile
Removable upholstery
Déhoussable
Abnehmbares Polsterzeug
Cubierta desmontable



Piedini intercambiabili
Interchangeable feet
Pieds interchangeables
Austauschbare Füße
Pies intercambiables



Caratteristiche costruttive
Construction characteristics
Caractéristiques de construction
Konstruktionsmerkmale
Características constructivas



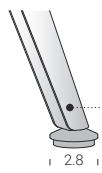

acciaio verniciato/painted steel
acier peint/lackierter Stahl
acero pintado

- C12 bianco/white
- C21 seta/silk
- C23 corda/ecru
- C30 ghisa/cast-iron
- C14 antracite/anthracite
- C08 nero/black
- C18 verde/green
- C26 corten/corten
- C29 bronzo/bronze
- C37 rame/copper
- C38 titanio/titanium

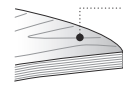

essenze/woods/bois
Holzes/maderas

- Y36 rovere/oak
- Y34 noce/walnut
- Y37 rovere affumicato/smoked oak
- Y39 frassino nero/black ash
- Y40 frassino argilla/clay ash

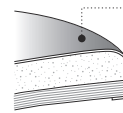

cuoio/cow-hide/cuir
Kernleder/cuero

- F01 tabacco/tobacco
- F02 nero/black

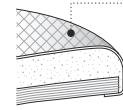

tessuto/fabric/tissu/Stoff/tela

poliestere
polyester

- JA01 perla/perl
- JA02 avorio/ivory
- JA03 fango/mud
- JA04 salvia/sage
- JA05 olivia/olive
- JA06 cipria/powder pink

JA-SF sfoderabile
removable
(pg.211)

misto cotone
mixed cotton

- JB01 natur/natur
- JB02 ecru/ecru
- JB03 grigio/grey
- JB04 cenere/ash
- JB05 platino/platinum
- JB06 antracite/anthracite

JB-SF sfoderabile
removable
(pg.211)

misto lino
mixed linen

- JC01 fumo/smoke
- JC02 cenere/ash
- JC03 sacco/sack
- JC04 terra/land
- JC05 verde/green
- JC06 rosa/pink

JC-SF sfoderabile
removable
(pg.211)

tessuto fornito
fabric provided

JX

JX-SF sfoderabile
removable
(pg.211)

SEDIA ECH6 / CHAIR ECH6 / CHAISE ECH6 / STUHL ECH6 / SILLA ECH6

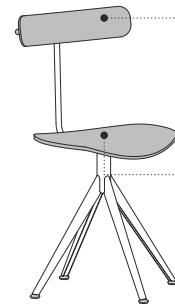
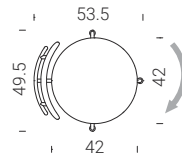
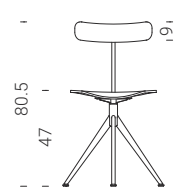

A
schienale adattivo
adjustable backrest
dossier adaptative
Adaptive Rückenlehne
respaldo adaptable

B
seduta
seat
assise
Sitzfläche
asiento

ESED0601	A										
	Y36	Y34	Y37	Y39	Y40	JA-SF	JB-SF	JC-SF	JX-SF	F	
B	Y36	493	-	-	-	-	555	558	564	-	552
	Y34	-	506	-	-	-	562	566	572	-	560
	Y37	-	-	513	-	-	568	571	577	-	565
	Y39	-	-	-	504	-	560	564	569	-	558
	Y40	-	-	-	-	503	559	563	568	-	557
	JA	426	432	432	432	432	487	-	-	-	-
	JB	432	439	439	439	439	-	497	-	-	-
	JC	442	449	449	449	449	-	-	513	-	-
	JX	426	432	432	432	432	-	-	-	487	-
	JA-SF	581	586	586	586	586	642	-	-	-	-
	JB-SF	584	590	590	590	590	-	650	-	-	-
JC-SF	599	606	606	606	606	-	-	670	-	-	
F	602	609	609	609	609	-	-	-	-	661	

SEDIA CON BRACCIOLI ECH6 / CHAIR WITH ARMRESTS ECH6 / CHAISE AVEC ACCOUDOIRS ECH6
STUHL MIT ARMLEHNE ECH6 / SILLA CON REPOSABRAZOS ECH6

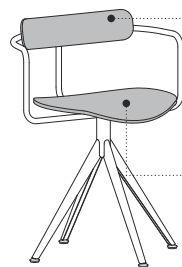
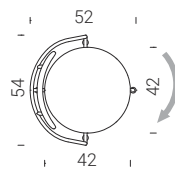
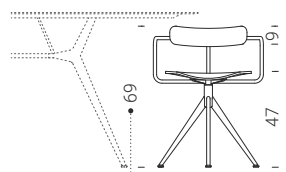

A
schienale adattivo
adjustable backrest
dossier adaptative
Adaptive Rückenlehne
respaldo adaptable

B
seduta
seat
assise
Sitzfläche
asiento

⚠ l'altezza dello schienale consente la rotazione della sedia sotto il top del tavolo.
the height of the backrest allows the chair to rotate below the table top.
la hauteur du dossier permet la rotation de la chaise sous le plateau de la table.
Die Höhe der Rückenlehne ermöglicht das Drehen des Stuhls unter der Tischplatte.
la altura del respaldo permite la rotación de la silla bajo la mesa.

ESED0602	A										
	Y36	Y34	Y37	Y39	Y40	JA-SF	JB-SF	JC-SF	JX-SF	F	
B	Y36	503	-	-	-	-	565	569	574	-	563
	Y34	-	517	-	-	-	573	576	582	-	570
	Y37	-	-	523	-	-	578	582	587	-	576
	Y39	-	-	-	514	-	570	574	580	-	568
	Y40	-	-	-	-	513	569	573	579	-	567
	JA	435	440	440	440	440	496	-	-	-	-
	JB	441	448	448	448	448	-	506	-	-	-
	JC	451	458	458	458	458	-	-	522	-	-
	JX	435	440	440	440	440	-	-	-	496	-
	JA-SF	591	598	598	598	598	652	-	-	-	-
	JB-SF	595	602	602	602	602	-	660	-	-	-
JC-SF	610	617	617	617	617	-	-	681	-	-	
F	612	619	619	619	619	-	-	-	-	671	

acciaio verniciato/painted steel
acier peint/lackierter Stahl
acero pintado

C12 bianco/white
C21 seta/silk
C23 corda/ecru
C30 ghisa/cast-iron
C14 antracite/anthracite
C08 nero/black
C18 verde/green
C26 corten/corten
C29 bronzo/bronze
C37 rame/copper
C38 titanio/titanium

essenze/woods/bois
Holzes/maderas

Y36 rovere/oak
Y34 noce/walnut
Y37 rovere affumicato/smoked oak
Y39 frassino nero/black ash
Y40 frassino argilla/clay ash

cuoio/cow-hide/cuir
Kernleder/cuero

F01 tabacco/tobacco
F02 nero/black

tessuto/fabric/tissu/Stoff/tela

poliestere
polyester

JA01 perla/perl
JA02 avorio/ivory
JA03 fango/mud
JA04 salvia/sage
JA05 olivia/olive
JA06 cipria/powder pink

misto cotone
mixed cotton

JB01 natur/natur
JB02 ecru/ecru
JB03 grigio/grey
JB04 cenere/ash
JB05 platino/platinum
JB06 antracite/anthracite

misto lino
mixed linen

JC01 fumo/smoke
JC02 cenere/ash
JC03 sacco/sack
JC04 terra/land
JC05 verde/green
JC06 rosa/pink

tessuto fornito
fabric provided

JX

JA-SF sfoderabile
removable
(pg.211)

JB-SF sfoderabile
removable
(pg.211)

JC-SF sfoderabile
removable
(pg.211)

JX-SF sfoderabile
removable
(pg.211)

SGABELLO ECH6 / STOOL ECH6 / TABOURET ECH6 / HOCKER ECH6 / TABURETE ECH6

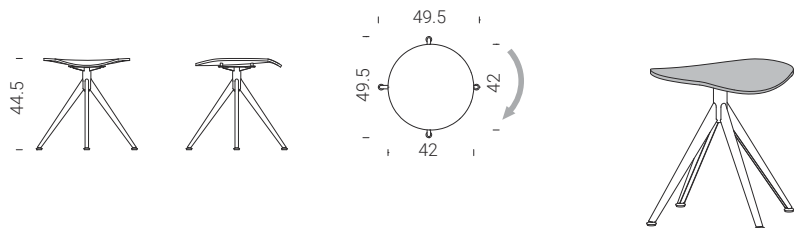

		Y36	Y34	Y37	Y39	Y40	
	ESED0603	337	344	350	342	341	
		JA	JB	JC	JX	JA-SF	JB-SF
	ESED0603	286	292	302	286	424	428
		JC-SF	F				
	ESED0603				443		446

SGABELLO CON BRACCIOLI ECH6 / STOOL WITH ARMRESTS ECH6 / TABOURET AVEC ACCOUDOIRS ECH6
HOCKER MIT ARMLEHNE ECH6 / TABURETE CON REPOSABRAZOS ECH6

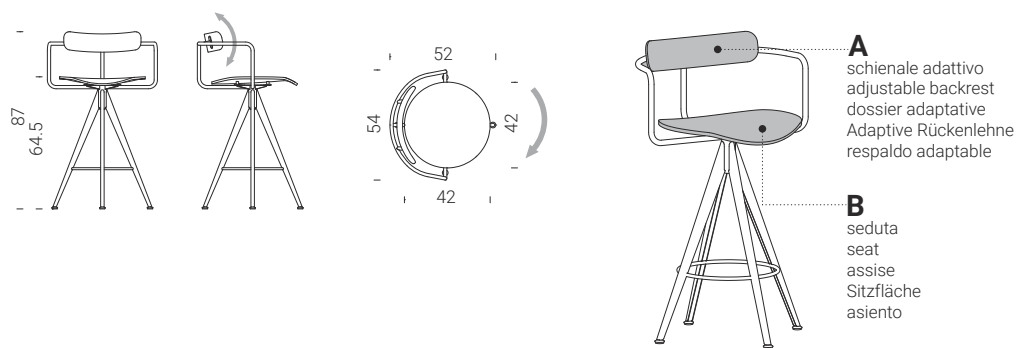

	ESED0604	A									
		Y36	Y34	Y37	Y39	Y40	JA-SF	JB-SF	JC-SF	JX-SF	F
B	Y36	520	-	-	-	-	581	585	591	-	579
	Y34	-	533	-	-	-	589	593	598	-	587
	Y37	-	-	540	-	-	594	598	604	-	592
	Y39	-	-	-	530	-	587	590	596	-	584
	Y40	-	-	-	-	529	585	589	595	-	583
	JA	448	455	455	455	455	510	-	-	-	-
	JB	455	462	462	462	462	-	520	-	-	-
	JC	465	472	472	472	472	-	-	536	-	-
	JX	448	455	455	455	455	-	-	-	510	-
	JA-SF	607	614	614	614	614	669	-	-	-	-
	JB-SF	611	618	618	618	618	-	676	-	-	-
JC-SF	626	633	633	633	633	-	-	697	-	-	
F	628	635	635	635	635	-	-	-	-	688	

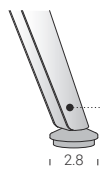

acciaio verniciato/painted steel
acier peint/lackierter Stahl
acero pintado

- C12** bianco/white
- C21** seta/silk
- C23** corda/ecru
- C30** ghisa/cast-iron
- C14** antracite/anthracite
- C08** nero/black
- C18** verde/green
- C26** corten/corten
- C29** bronzo/bronze
- C37** rame/copper
- C38** titanio/titanium

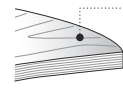

essenze/woods/bois
Holzes/maderas

- Y36** rovere/oak
- Y34** noce/walnut
- Y37** rovere affumicato/smoked oak
- Y39** frassino nero/black ash
- Y40** frassino argilla/clay ash

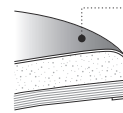

cuoio/cow-hide/cuir
Kernleder/cuero

- F01** tabacco/tobacco
- F02** nero/black

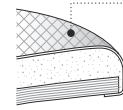

tessuto/fabric/tissu/Stoff/tela

poliestere
polyester

- JA01** perla/perl
- JA02** avorio/ivory
- JA03** fango/mud
- JA04** salvia/sage
- JA05** olivia/olive
- JA06** cipria/powder pink

JA-SF sfoderabile
removable
(pg.211)

misto cotone
mixed cotton

- JB01** natur/natur
- JB02** ecru/ecru
- JB03** grigio/grey
- JB04** cenere/ash
- JB05** platino/platinum
- JB06** antracite/anthracite

JB-SF sfoderabile
removable
(pg.211)

misto lino
mixed linen

- JC01** fumo/smoke
- JC02** cenere/ash
- JC03** sacco/sack
- JC04** terra/land
- JC05** verde/green
- JC06** rosa/pink

JC-SF sfoderabile
removable
(pg.211)

tessuto fornito
fabric provided

JX

SGABELLO H=64.5 ECH6 / STOOL H=64.5 ECH6 / TABOURET H=64.5 ECH6
HOCKER H=64.5 ECH6 / TABURETE H=64.5 ECH6

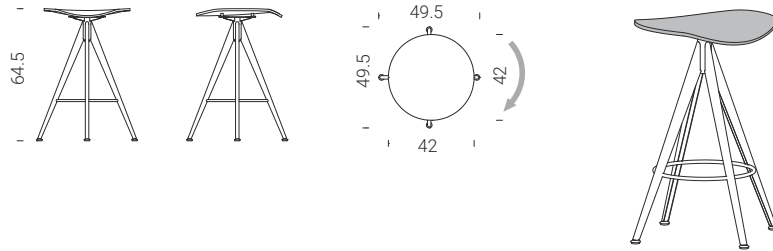

		Y36	Y34	Y37	Y39	Y40		
	ESED0605	360	368	373	366	365		
		JA	JB	JC	JX	JA-SF	JB-SF	JC-SF
ESED0605	306	312	322	306	448	452	467	469

ECH7



NEL BASAMENTO DAL RIDOTTO INGOMBRO, LE RAZZE, COSTITUITE DA PROFILI DI 16 MM, SI CURVANO E SI RACCORDANO CON UN ELEMENTO A CROCIERA CREANDO UN UNICO CORPO SALDATO. GLI SCHIENALI ADATTIVI E GLI AMPI FONDELLI OVALI IN TESSUTO SFODERABILE SONO DISPONIBILI NELLA VERSIONE CON O SENZA BRACCIOLI.

On the small sized base, the spokes, with 16 mm profiles, bend and connect with a cross element, creating a single welded body. The adjustable backrests and large removable upholstery oval chair seats are available with or without arms.

Dans la base compacte, les rayons, constitués de profilés de 16 mm, se plient et se connectent à un élément transversal pour créer un unique corps soudé. Les dossiers adaptatifs et les vastes fonds ovales en tissu amovible sont disponibles dans la version avec ou sans accoudoirs.

Im kleinen Untergestell biegen sich die aus 16 mm Profilen bestehenden Speichen und verbinden sich mit einem kreuzförmigen Element und bilden so einen einzigen Körper. Die adaptiven Rückenlehnen und die großen ovalen Sitzflächen mit abnehmbarem Polsterzeug sind in der Version mit oder ohne Armlehnen verfügbar.

En la base que ahorra espacio, los radios fabricados con perfiles de 16 mm se curvan y se unen con un elemento en forma de cruz para crear un único cuerpo soldado. Los respaldos adaptables y los grandes respaldos ovalados con fundas de tela extraíbles están disponibles con o sin reposabrazos.



Schienale adattivo
Adjustable backrest
Dossier adaptatif
Adaptive Rückenlehne
Respaldo adaptable



ADAPTIVE
CHAIR BACKREST
registered community
design



Sfoderabile
Removable upholstery
Déhoussable
Abnehmbares Polsterzeug
Cubierta desmontable



Piedini intercambiabili
Interchangeable feet
Pieds interchangeables
Austauschbare Füße
Pies intercambiables



Caratteristiche costruttive
Construction characteristics
Caractéristiques de construction
Konstruktionsmerkmale
Características constructivas



acciaio verniciato/painted steel
acier peint/lackierter Stahl
acero pintado

C12 bianco/white
C21 seta/silk
C23 corda/ecru
C30 ghisa/cast-iron
C14 antracite/anthracite
C08 nero/black
C18 verde/green
C26 corten/corten
C29 bronzo/bronze
C37 rame/copper
C38 titanio/titanium

essenze/woods/bois
Holzes/maderas

Y36 rovere/oak
Y34 noce/walnut
Y37 rovere affumicato/smoked oak
Y39 frassino nero/black ash
Y40 frassino argilla/clay ash

cuoio/cow-hide/cuir
Kernleder/cuero

F01 tabacco/tobacco
F02 nero/black

tessuto/fabric/tissu/Stoff/tela

poliestere
polyester

JA01 perla/perl
JA02 avorio/ivory
JA03 fango/mud
JA04 salvia/sage
JA05 olivia/olive
JA06 cipria/powder pink

JA-SF sfoderabile
removable
(pg.211)

misto cotone
mixed cotton

JB01 natur/natur
JB02 ecru/ecru
JB03 grigio/grey
JB04 cenere/ash
JB05 platino/platinum
JB06 antracite/anthracite

JB-SF sfoderabile
removable
(pg.211)

misto lino
mixed linen

JC01 fumo/smoke
JC02 cenere/ash
JC03 sacco/sack
JC04 terra/land
JC05 verde/green
JC06 rosa/pink

JC-SF sfoderabile
removable
(pg.211)

tessuto fornito
fabric provided

JX

JX-SF sfoderabile
removable
(pg.211)

SEDIA ECH7 / CHAIR ECH7 / CHAISE ECH7 / STUHL ECH7 / SILLA ECH7

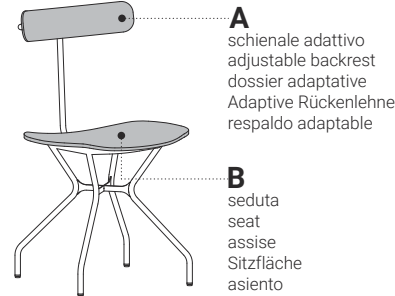
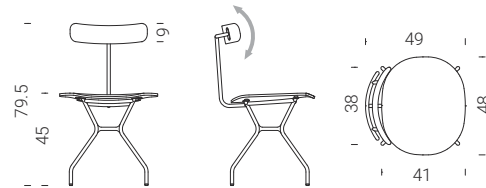

ESED0701		A									
		Y36	Y34	Y37	Y39	Y40	JA-SF	JB-SF	JC-SF	JX-SF	F
B	Y36	434	-	-	-	-	495	499	505	-	493
	Y34	-	447	-	-	-	503	507	512	-	501
	Y37	-	-	454	-	-	508	512	518	-	506
	Y39	-	-	-	445	-	501	505	510	-	499
	Y40	-	-	-	-	443	500	503	509	-	497
	JA	375	382	382	382	382	436	-	-	-	-
	JB	381	388	388	388	388	-	446	-	-	-
	JC	391	398	398	398	398	-	-	462	-	-
	JX	375	382	382	382	382	-	-	-	436	-
	JA-SF	521	528	528	528	528	583	-	-	-	-
	JB-SF	525	532	532	532	532	-	590	-	-	-
JC-SF	540	547	547	547	547	-	-	611	-	-	
F	543	549	549	549	549	-	-	-	-	602	

SEDIA CON BRACCIOLI ECH7 / CHAIR WITH ARMRESTS ECH7 / CHAISE AVEC ACCOUDOIRS ECH7 STUHL MIT ARMLEHNE ECH7 / SILLA CON REPOSABRAZOS ECH7

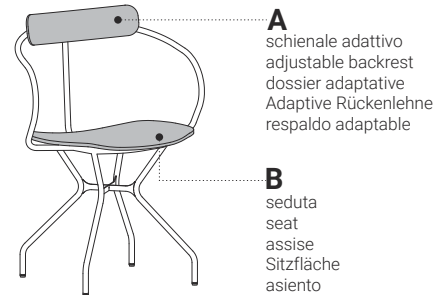
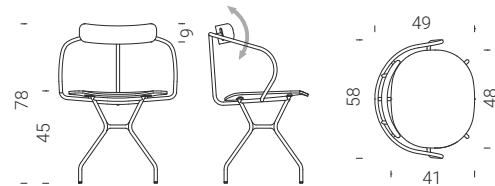

ESED0702		A									
		Y36	Y34	Y37	Y39	Y40	JA-SF	JB-SF	JC-SF	JX-SF	F
B	Y36	446	-	-	-	-	508	512	517	-	506
	Y34	-	460	-	-	-	516	519	525	-	513
	Y37	-	-	466	-	-	521	525	530	-	519
	Y39	-	-	-	457	-	513	517	523	-	511
	Y40	-	-	-	-	456	512	516	522	-	510
	JA	385	392	392	392	392	447	-	-	-	-
	JB	392	399	399	399	399	-	457	-	-	-
	JC	402	409	409	409	409	-	-	473	-	-
	JX	385	392	392	392	392	-	-	-	447	-
	JA-SF	534	541	541	541	541	595	-	-	-	-
	JB-SF	538	545	545	545	545	-	603	-	-	-
JC-SF	553	560	560	560	560	-	-	624	-	-	
F	555	562	562	562	562	-	-	-	-	614	

CUSCINO / CUSHION / COUSSIN / KISSEN / COJÍN

il cuscino va abbinato ai fondelli in essenza Y36/Y34/Y37/Y39/Y40
the cushion must be matched with the wooden seats in Y36/Y34/Y37/Y39/Y40 essences
le coussin doit être associé aux dossiers en bois Y36/Y34/Y37/Y39/Y40
Das Kissen muss an die Sitzflächen aus Holz Y36/Y34/Y37/Y39/Y40 angepasst werden
El cojín va combinado con los respaldos de madera Y36/Y34/Y37/Y39/Y40

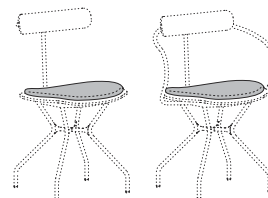

	JA	JB	JC	JX	F
EACS0301	120	128	140	120	178

il cuscino non è ordinabile successivamente
the cushion cannot be ordered later
le coussin ne peut pas être commandé successivement
Das Kissen kann nicht im Nachhinein bestellt werden
El cojín no se puede encargar con posterioridad

ricambi a pg. 203 / spare parts on page 203 / pièces de rechange p.203
Ersatzteile auf S. 203 / Recambios en pág. 203

ECH8



IL FONDELLO DALLA FORMA AMPIA, RICORDA PER DIMENSIONI E GEOMETRIE LE SEDUTE PIÙ CLASSICHE. IL FONDELLO E LO SCHIENALE SONO DISPONIBILI CON RIVESTIMENTO SFODERABILE PER CONSENTIRNE IL LAVAGGIO O L'EVENTUALE RICAMBIO. IL MECCANISMO APPLICATO AGLI SCHIENALI ADATTIVI TRAMITE UN'OSCILLAZIONE CONTROLLATA SEGUE E SOSTIENE IL MOVIMENTO DELLA SCHIENA.

The large seat recalls the more classical seats in terms of dimensions and geometries. The seat and backrest are available with removable upholstery to allow for their washing and changing. The mechanism applied to the adjustable backrests by means of controlled rocking follows and supports the movement of the back.

Le large fond rappelle les sièges plus classiques en termes de taille et de géométrie. Le coussin et le dossier sont disponibles avec des housses amovibles afin d'en permettre le lavage et le remplacement. Le mécanisme appliqué aux dossiers adaptatifs, au moyen d'une oscillation contrôlée, suit et soutient le mouvement du dossier.

Die breite Sitzfläche erinnert durch Größe und Formen an die klassischen Sitzmöbel. Die Sitzfläche und die Rückenlehne sind mit abnehmbarem Polsterzeug verfügbar, um das Waschen und den eventuellen Austausch zu ermöglichen. Der für die adaptiven Rückenlehnen verwendete Mechanismus begleitet und unterstützt durch kontrolliertes Schwanken die Bewegung des Rückens.

El amplio respaldo recuerda en tamaño y geometría a los asientos clásicos. El asiento y el respaldo están disponibles con fundas extraíbles para su lavado o sustitución. El mecanismo aplicado a los respaldos adaptables mediante una oscilación controlada sigue y apoya el movimiento de la espalda.



Schienale adattivo
Adjustable backrest
Dossier adaptatif
Adaptive Rückenlehne
Respaldo adaptable



ADAPTIVE
CHAIR BACKREST
registered community
design



Sfoderabile
Removable upholstery
Déhoussable
Abnehmbares Polsterzeug
Cubierta desmontable



Piedini intercambiabili
Interchangeable feet
Pieds interchangeables
Austauschbare Füße
Pies intercambiables



Caratteristiche costruttive
Construction characteristics
Caractéristiques de construction
Konstruktionsmerkmale
Características constructivas



acciaio verniciato/painted steel
acier peint/lackierter Stahl
acero pintado

C12 bianco/white
C21 seta/silk
C23 corda/ecru
C30 ghisa/cast-iron
C14 antracite/anthracite
C08 nero/black
C18 verde/green
C26 corten/corten
C29 bronzo/bronze
C37 rame/copper
C38 titanio/titanium

essenze/woods/bois
Holzes/maderas

Y36 rovere/oak
Y34 noce/walnut
Y37 rovere affumicato/smoked oak
Y39 frassino nero/black ash
Y40 frassino argilla/clay ash

cuoio/cow-hide/cuir
Kernleder/cuero

F01 tabacco/tobacco
F02 nero/black

tessuto/fabric/tissu/Stoff/tela

poliestere
polyester

JA01 perla/perl
JA02 avorio/ivory
JA03 fango/mud
JA04 salvia/sage
JA05 olivia/olive
JA06 cipria/powder pink

JA-SF sfoderabile
removable
(pg.211)

misto cotone
mixed cotton

JB01 natur/natur
JB02 ecru/ecru
JB03 grigio/grey
JB04 cenere/ash
JB05 platino/platinum
JB06 antracite/anthracite

JB-SF sfoderabile
removable
(pg.211)

misto lino
mixed linen

JC01 fumo/smoke
JC02 cenere/ash
JC03 sacco/sack
JC04 terra/land
JC05 verde/green
JC06 rosa/pink

JC-SF sfoderabile
removable
(pg.211)

tessuto fornito
fabric provided

JX

JX-SF sfoderabile
removable
(pg.211)

SEDIA ECH8 / CHAIR ECH8 / CHAISE ECH8 / STUHL ECH8 / SILLA ECH8

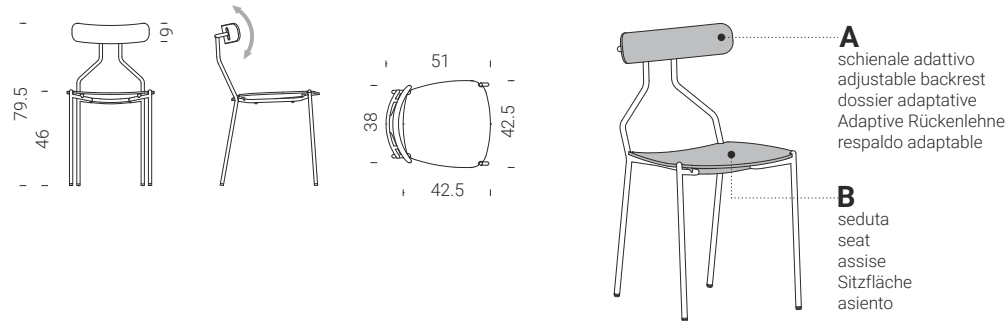

ESED0801		A									
		Y36	Y34	Y37	Y39	Y40	JA-SF	JB-SF	JC-SF	JX-SF	F
B	JA	338	345	345	345	345	400	-	-	-	-
	JB	345	352	352	352	352	-	410	-	-	-
	JC	355	362	362	362	362	-	-	426	-	-
	JX	338	345	345	345	345	-	-	-	400	-
	JA-SF	479	486	486	486	486	541	-	-	-	-
	JB-SF	483	490	490	490	490	-	548	-	-	-
	JC-SF	498	505	505	505	505	-	-	569	-	-
F	500	507	507	507	507	-	-	-	-	560	

SEDIA CON BRACCIOLI ECH8 / CHAIR WITH ARMRESTS ECH8 / CHAISE AVEC ACCOUDOIRS ECH8 STUHL MIT ARMLEHNE ECH8 / SILLA CON REPOSABRAZOS ECH8

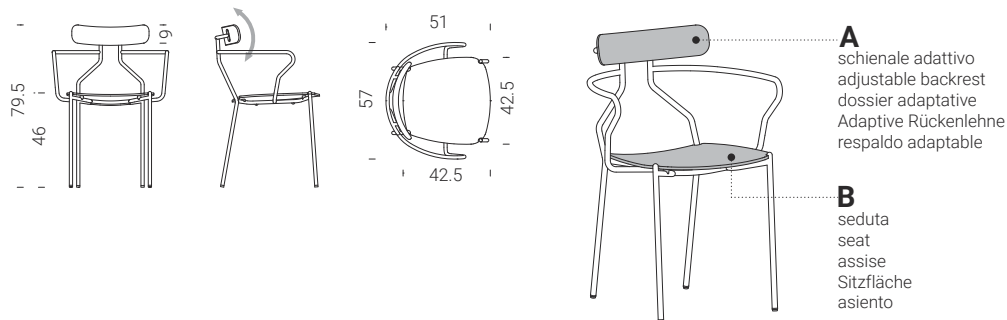

ESED0802		A									
		Y36	Y34	Y37	Y39	Y40	JA-SF	JB-SF	JC-SF	JX-SF	F
B	JA	355	362	362	362	362	417	-	-	-	-
	JB	362	369	369	369	369	-	427	-	-	-
	JC	372	379	379	379	379	-	-	443	-	-
	JX	355	362	362	362	362	-	-	-	417	-
	JA-SF	499	506	506	506	506	561	-	-	-	-
	JB-SF	503	510	510	510	510	-	568	-	-	-
	JC-SF	518	525	525	525	525	-	-	589	-	-
F	520	527	527	527	527	-	-	-	-	580	

ECH9



LA VERSATILITÀ DEL PROGETTO DEL 1927 DI CHARLOTTE PERRIAND PER IL SUO APPARTAMENTO PARIGINO DI PLACE SAINT-SULPICE ISPIRA QUESTA FAMIGLIA DI SEDUTE CARATTERIZZATA DA SCHIENALE ADATTIVO. EXTENDO LA REINTERPRETA DISEGNANDO LA VERSIONE CON BRACCIOLI CHE NE CONSENTE LA COMPLETA ROTAZIONE AL DI SOTTO DEL TOP TAVOLO, AGEVOLANDO L'ACCESSIBILITÀ ALLA SEDUTA.

The versatility of the 1927 project of Charlotte Perriand for his Parisian apartment in Place Saint-Sulpice inspires this family of chairs with adjustable back. Extendo re-interprets it, designing a version with arms that allows full rotation under the table top, facilitating accessibility and seating.

La versatilité du projet de 1927 de Charlotte Perriand pour son appartement parisien de la place Saint-Sulpice inspire cette famille de sièges caractérisée par leur dossier adaptatif. Extendo propose une réinterprétation avec une version à accoudoirs et rotation complète sous le plateau de la table pour faciliter l'accès au siège.

Die Vielseitigkeit des Projekts von 1927 von Charlotte Perriand für sein Pariser Apartment am Place Saint-Sulpice inspiriert diese durch die adaptive Rückenlehne gekennzeichnete Familie von Sitzmöbel. Extendo interpretiert sie neu und entwirft die Version mit Armlehnen, die die komplette Drehung unterhalb der Tischplatte ermöglichen und so das Sitzen erleichtern.

La versatilidad del diseño de Charlotte Perriand de 1927 para su piso parisino de la plaza Saint-Sulpice inspiró esta familia de sillas con respaldo adaptable. Extendo lo reinterpreta diseñando una versión con reposabrazos que le permite girar completamente por debajo del tablero, facilitando el acceso al asiento.



Schienale adattivo
Adjustable backrest
Dossier adaptatif
Adaptive Rückenlehne
Respaldo adaptable



ADAPTIVE
CHAIR BACKREST
registered community
design



Sfoderabile
Removable upholstery
Déhoussable
Abnehmbares Polsterzeug
Cubierta desmontable



Piedini intercambiabili
Interchangeable feet
Pieds interchangeables
Austauschbare FüÙe
Pies intercambiables



Caratteristiche costruttive
Construction characteristics
Caractéristiques de construction
Konstruktionsmerkmale
Características constructivas



acciaio verniciato/painted steel
acier peint/lackierter Stahl
acero pintado

C12 bianco/white
C21 seta/silk
C23 corda/ecru
C30 ghisa/cast-iron
C14 antracite/anthracite
C08 nero/black
C18 verde/green
C26 corten/corten
C29 bronzo/bronze
C37 rame/copper
C38 titanio/titanium

essenze/woods/bois
Holzes/maderas

Y36 rovere/oak
Y34 noce/walnut
Y37 rovere affumicato/smoked oak
Y39 frassino nero/black ash
Y40 frassino argilla/clay ash

cuoio/cow-hide/cuir
Kernleder/cuero

F01 tabacco/tobacco
F02 nero/black

tessuto/fabric/tissu/Stoff/tela

poliestere
polyester

JA01 perla/perl
JA02 avorio/ivory
JA03 fango/mud
JA04 salvia/sage
JA05 olivia/olive
JA06 cipria/powder pink

misto cotone
mixed cotton

JB01 natur/natur
JB02 ecru/ecru
JB03 grigio/grey
JB04 cenere/ash
JB05 platino/platinum
JB06 antracite/anthracite

misto lino
mixed linen

JC01 fumo/smoke
JC02 cenere/ash
JC03 sacco/sack
JC04 terra/land
JC05 verde/green
JC06 rosa/pink

tessuto fornito
fabric provided

JX

JA-SF sfoderabile
removable
(pg.211)

JB-SF sfoderabile
removable
(pg.211)

JC-SF sfoderabile
removable
(pg.211)

JX-SF sfoderabile
removable
(pg.211)

SEDIA ECH9 / CHAIR ECH9 / CHAISE ECH9 / STUHL ECH9 / SILLA ECH9

A schienale adattivo
adjustable backrest
dossier adaptative
Adaptive Rückenlehne
respaldo adaptable

B seduta
seat
assise
Sitzfläche
asiento

ESED0901	A									
	Y36	Y34	Y37	Y39	Y40	JA-SF	JB-SF	JC-SF	JX-SF	F
B	Y36	500	-	-	-	561	565	571	-	559
	Y34	-	513	-	-	569	573	578	-	567
	Y37	-	-	520	-	574	578	584	-	572
	Y39	-	-	-	511	567	571	576	-	565
	Y40	-	-	-	-	509	566	569	575	563
	JA	431	438	438	438	438	493	-	-	-
	JB	438	445	445	445	445	-	503	-	-
	JC	448	455	455	455	455	-	-	519	-
	JX	431	438	438	438	438	-	-	-	493
	JA-SF	587	594	594	594	594	649	-	-	-
	JB-SF	591	598	598	598	598	-	656	-	-
	JC-SF	606	613	613	613	613	-	-	677	-
F	609	616	616	616	616	-	-	-	-	668

**SEDIA CON BRACCIOLI ECH9 / CHAIR WITH ARMRESTS ECH9 / CHAISE AVEC ACCOUDOIRS ECH9
STUHL MIT ARMLEHNE ECH9 / SILLA CON REPOSABRAZOS ECH9**

A schienale adattivo
adjustable backrest
dossier adaptative
Adaptive Rückenlehne
respaldo adaptable

B seduta
seat
assise
Sitzfläche
asiento

l'altezza dello schienale consente la rotazione della sedia sotto il top del tavolo.
the height of the backrest allows the chair to rotate below the table top.
la hauteur du dossier permet la rotation de la chaise sous le plateau de la table.
Die Höhe der Rückenlehne ermöglicht das Drehen des Stuhls unter der Tischplatte.
la altura del respaldo permite la rotación de la silla bajo la mesa.

ESED0902	A									
	Y36	Y34	Y37	Y39	Y40	JA-SF	JB-SF	JC-SF	JX-SF	F
B	Y36	510	-	-	-	572	576	581	-	570
	Y34	-	524	-	-	579	583	589	-	577
	Y37	-	-	530	-	585	589	594	-	583
	Y39	-	-	-	521	577	581	587	-	575
	Y40	-	-	-	-	520	576	580	586	574
	JA	440	447	447	447	447	502	-	-	-
	JB	447	454	454	454	454	-	512	-	-
	JC	457	464	464	464	464	-	-	528	-
	JX	440	447	447	447	447	-	-	-	502
	JA-SF	598	605	605	605	605	659	-	-	-
	JB-SF	602	609	609	609	609	-	667	-	-
	JC-SF	617	624	624	624	624	-	-	688	-
F	619	626	626	626	626	-	-	-	-	678

SGABELLO ECH9 / STOOL ECH9 / TABOURET ECH9 / HOCKER ECH9 / TABURETE ECH9

ESED0903	Y36	Y34	Y37	Y39	Y40			
	357	364	370	362	361			
ESED0903	JA	JB	JC	JX	JA-SF	JB-SF	JC-SF	F
	303	309	319	303	444	448	463	465

ricambi a pg. 203 / spare parts on page 203 / pièces de rechange p.203
Ersatzteile auf S. 203 / Recambios en pág. 203

CONTRAPPESO

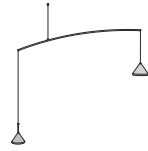

UN CONTRAPPESO IN MARMO O ACCIAIO MANTIENE IN POSIZIONE IL CORPO ILLUMINANTE. AVVOLGENDO IL CAVO ALLA BITTA POSIZIONATA SUL CONTRAPPESO È POSSIBILE REGOLARE IN ALTEZZA IL CORPO ILLUMINATE. SPOSTANDO IL CONTRAPPESO, LA FONTE LUMINOSA RUOTA ATTORNO AL PUNTO DI SOSPENSIONE CONSENTENDO DI RAGGIUNGERE PUNTI LONTANI DALLA PRESA ELETTRICA.

A marble or steel counterweight keeps the lighting fixture in position. By winding the cable around the bitt on the counterweight it is possible to adjust the height of the lighting fixture. Moving the counterweight, the light source rotates around the suspension point, allowing points further away from the electrical output to be reached.

Un contrepoids en marbre ou en acier maintient le corps lumineux en position. Il est possible de régler la hauteur du corps lumineux en enroulant le câble autour de la borne positionnée sur le contrepoids. En déplaçant le contrepoids, la source lumineuse tournera autour du point de suspension, permettant ainsi d'atteindre des points éloignés de la prise électrique.

Ein Gegengewicht aus Marmor oder Stahl hält den Leuchtkörper in Position. Wenn man den Kabel um den Poller auf dem Gegengewicht wickelt, kann man die Höhe des Leuchtkörpers einstellen. Durch Verlegung des Gegengewichts dreht sich die Lichtquelle um den Schwebepunkt und so können auch die von der Steckdose entfernten Punkte erreicht werden.

Un contrapeso de mármol o acero mantiene la luminaria en su sitio. Enrollando el cable alrededor del bolardo del contrapeso, se puede ajustar la altura de la luminaria. Moviendo el contrapeso, la fuente de luz gira alrededor del punto de suspensión, lo que permite llegar a lugares alejados de la toma de corriente.



LAMPS
registered community
design



ø20 cm ø30 cm

Led Module: SMD LED
MOUNTED ON MODULE CLE 160 mm. ADV4
Lumen: 3100 lm
Power: 650 mA
INPUT: 220 - 240 V | 50/60 Hz
Color temperature: 3000 K
Dimming range 1 - 100 %
CRI: >80



ø40 cm

Led Module: SMD LED
MOUNTED ON MODULE CLE 315 mm. ADV4
Lumen: 4200 lm
Power: 900 mA
INPUT: 220 - 240 V | 50/60 Hz
Color temperature: 3000 K
Dimming range 1 - 100 %
CRI: >80

C alluminio verniciato/painted aluminium/aluminium peint lackierter Aluminium/aluminio pintado

C12 bianco/white	C08 nero/black
C21 seta/silk	C29 bronzo/bronze
C23 corda/ecru	C37 rame/copper
C30 ghisa/cast-iron	C38 titanio/titanium
C14 antracite/anthracite	

C acciaio verniciato/painted steel/acier peint lackierter Stahl/acero pintado

C12 bianco/white	C08 nero/black
C21 seta/silk	C29 bronzo/bronze
C23 corda/ecru	C37 rame/copper
C30 ghisa/cast-iron	C38 titanio/titanium
C14 antracite/anthracite	

Z marmo/marble/marbre Marmor/mármol

Z01 bianco Carrara/Carrara white
Z02 nero Marquiña/black Marquiña
Z03 verde Alpi/Alpi green

LAMPADA A SOFFITTO / CEILING LAMP / PLAFONNIER
DECKENLAMPE / LÁMPARA DE TECHO

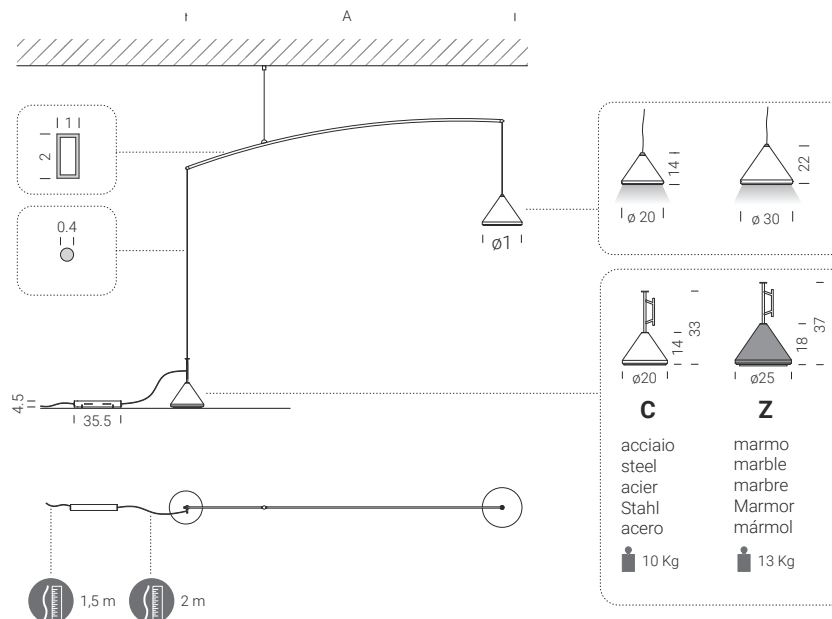
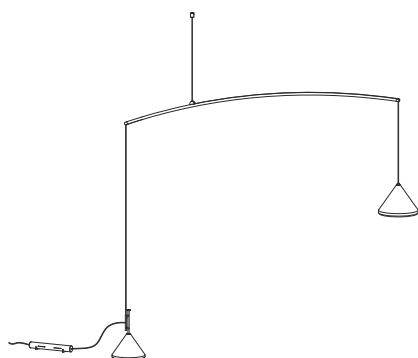

	A	ø1	C	Z
ELAM0101	180	ø 20	970	1666
ELAM0102	180	ø 30	1007	1700
ELAM0103	210	ø 20	977	1673
ELAM0104	210	ø 30	1014	1707
ELAM0105	240	ø 20	988	1683
ELAM0106	240	ø 30	1025	1717

MOVIMENTI POSSIBILI / POSSIBLE MOVEMENTS / MOUVEMENTS POSSIBLE
MÖGLICHE BEWEGUNGEN / MOVIMIENTOS POSIBLES

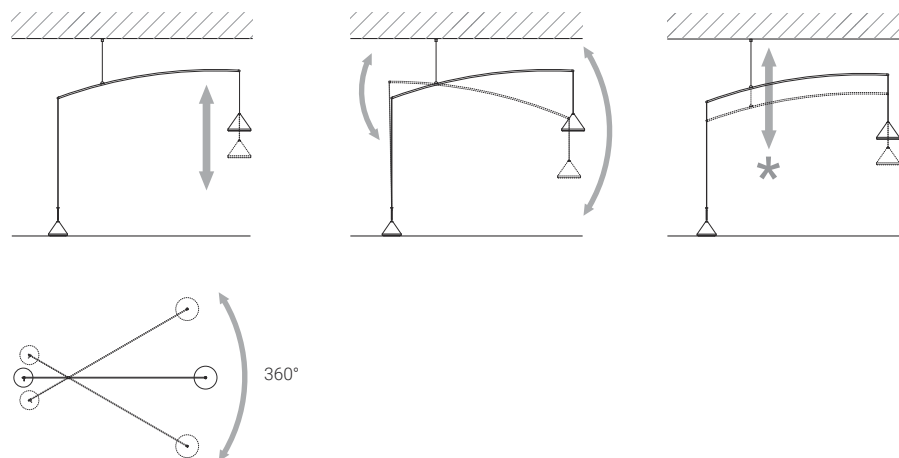

ESEMPI DI INSTALLAZIONE / EXAMPLES OF INSTALLATION / EXEMPLES D'INSTALLATION
INSTALLATIONSBEISPIELE / EJEMPLOS DE INSTALACIÓN

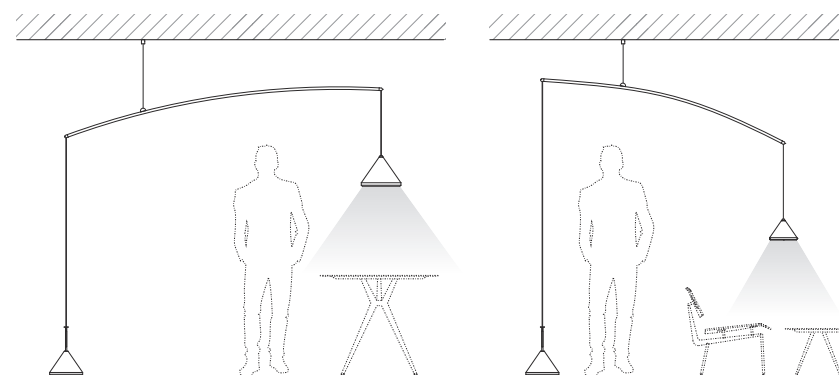

regolazioni da effettuare in fase di installazione
adjustments to make during installation
réglages à effectuer lors de l'installation
Bei der Installation vorzunehmende Regulierungen
ajustes a realizar durante la instalación

ℓ
lunghezza filo
length of wire
longueur de fil
Schnurlänge
Longitud cable

?
informazioni e ricambi a pg.233
information and spare parts on page 233
informations et pièces de rechange p. 233
Infos und Ersatzteile auf S.233
Información y recambios en pág.233

▶
Caratteristiche costruttive
Construction characteristics
Caractéristiques de construction
Konstruktionsmerkmale
Características constructivas

C alluminio verniciato/painted aluminium/aluminium peint lackierter Aluminium/aluminio pintado

C12 bianco/white	C08 nero/black
C21 seta/silk	C29 bronzo/bronze
C23 corda/ecru	C37 rame/copper
C30 ghisa/cast-iron	C38 titanio/titanium
C14 antracite/anthracite	

C acciaio verniciato/painted steel/acier peint lackierter Stahl/acero pintado

C12 bianco/white	C08 nero/black
C21 seta/silk	C29 bronzo/bronze
C23 corda/ecru	C37 rame/copper
C30 ghisa/cast-iron	C38 titanio/titanium
C14 antracite/anthracite	

Z marmo/marble/marbre
Marmor/mármol

Z01 bianco Carrara/Carrara white
Z02 nero Marquìña/black Marquìña
Z03 verde Alpi/Alpi green

LAMPADA A PARETE / WALL LAMP / APPLIQUE
WANDLAMPE / LÁMPARA DE PARED

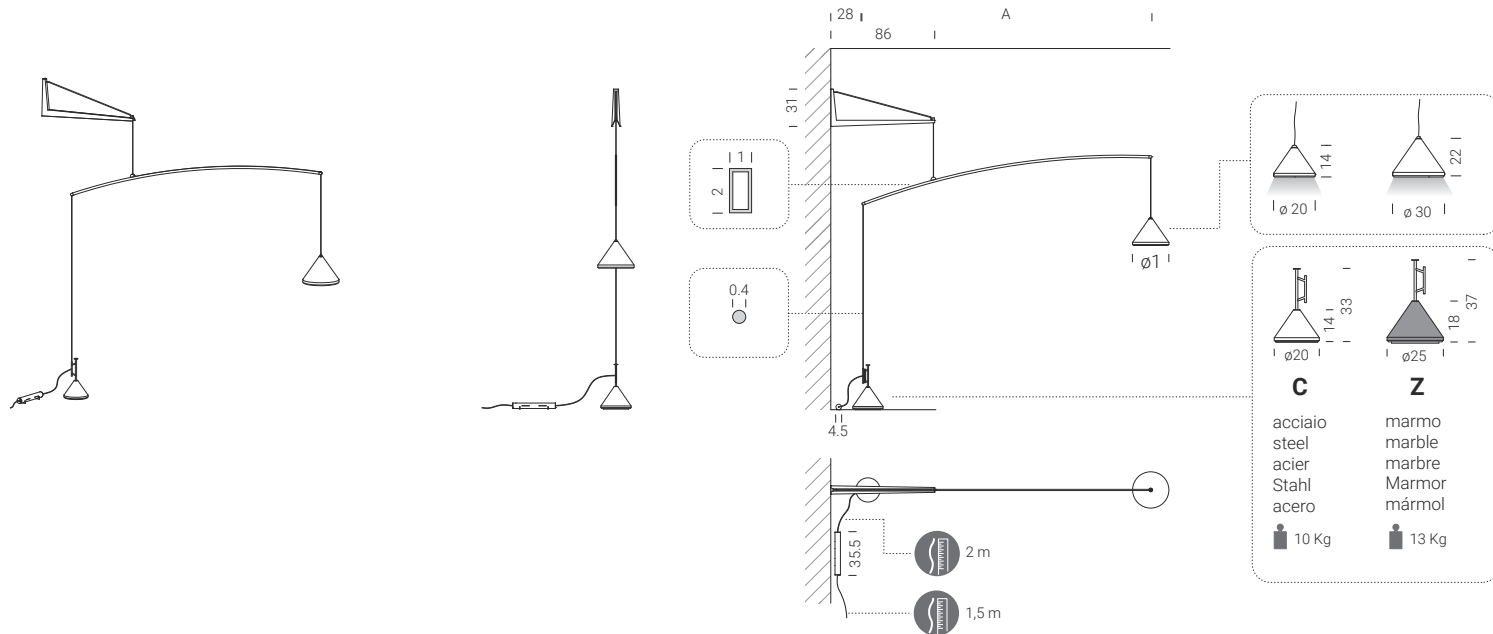

	A	ø1	C	Z
ELAM0107	180	ø 20	1090	1776
ELAM0108	180	ø 30	1127	1810
ELAM0109	210	ø 20	1097	1783
ELAM0110	210	ø 30	1134	1817
ELAM0111	240	ø 20	1108	1793
ELAM0112	240	ø 30	1145	1827

MOVIMENTI POSSIBILI / POSSIBLE MOVEMENTS / MOUVEMENTS POSSIBLE
MÖGLICHE BEWEGUNGEN / MOVIMIENTOS POSIBLES

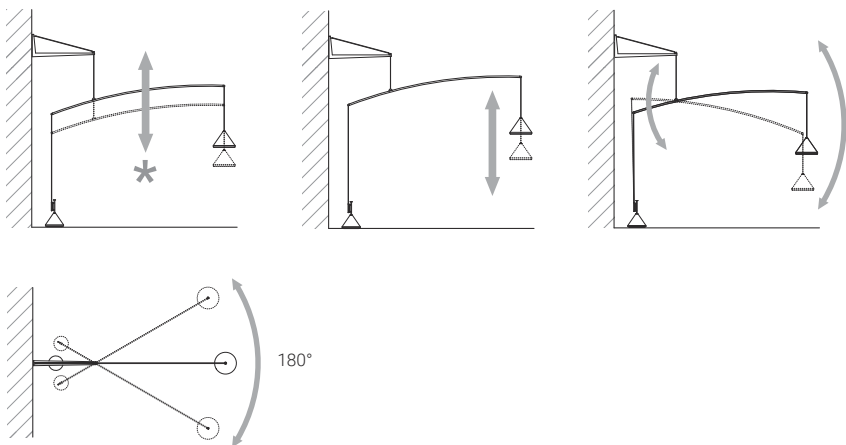

ESEMPLI DI INSTALLAZIONE / EXAMPLES OF INSTALLATION / EXEMPLES D'INSTALLATION
INSTALLATIONSBEISPIELE / EJEMPLOS DE INSTALACIÓN

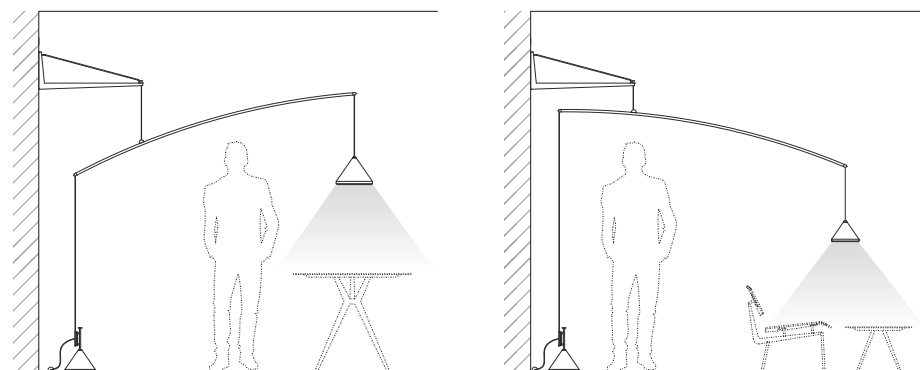

regolazioni da effettuare in fase di installazione
adjustments to make during installation
réglages à effectuer lors de l'installation
Bei der Installation vorzunehmende Regulierungen
ajustes a realizar durante la instalación

?
lunghezza filo
length of wire
longueur de fil
Schnurlänge
Longitud cable

?
informazioni e ricambi a pg.233
information and spare parts on page 233
informations et pièces de rechange p. 233
Infos und Ersatzteile auf S.233
Información y recambios en pág.233

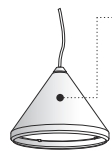

C alluminio verniciato/painted aluminium/aluminium peint lackierter Aluminium/aluminio pintado

- | | |
|---------------------------------|-----------------------------|
| C12 bianco/white | C08 nero/black |
| C21 seta/silk | C29 bronzo/bronze |
| C23 corda/ecru | C37 rame/copper |
| C30 ghisa/cast-iron | C38 titanio/titanium |
| C14 antracite/anthracite | |

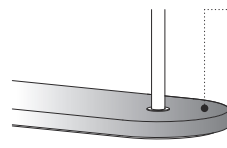

Z marmo/marble/marbre Marmor/mármol

- | |
|---|
| Z01 bianco Carrara/Carrara white |
| Z02 nero Marquiña/black Marquiña |
| Z03 verde Alpi/Alpi green |

LAMPADA A LIBERA INSTALLAZIONE / FREE STANDING LAMP / LAMPE AVEC INSTALLATION LIBRE
FREI INSTALLIERBARE LAMPE / LÁMPARA DE LIBRE INSTALACIÓN

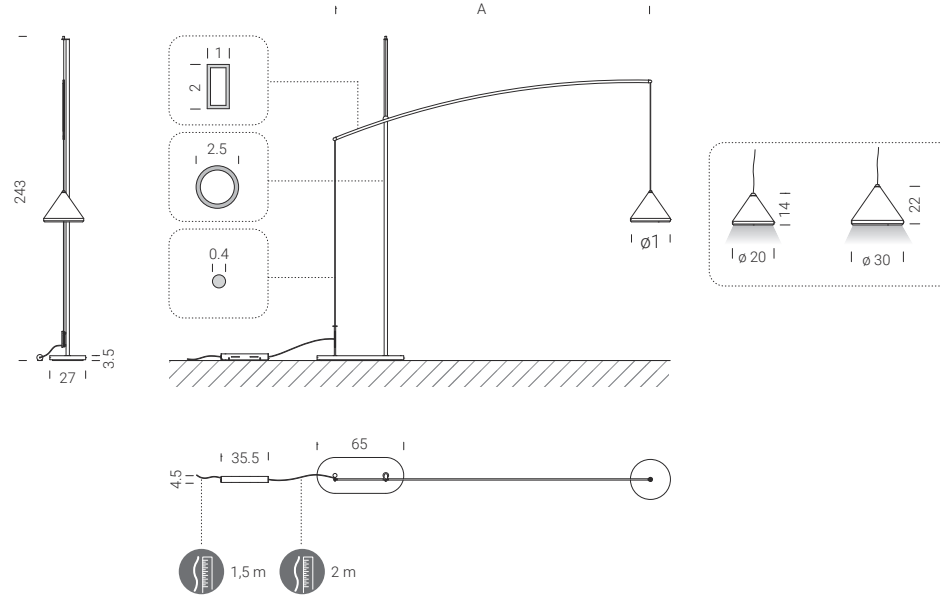
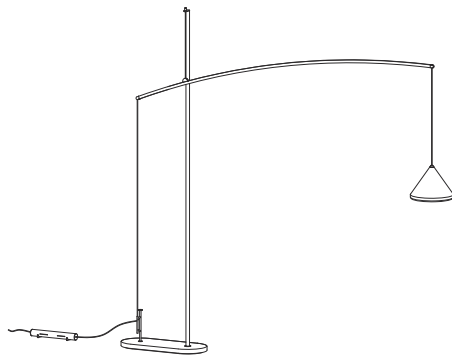

	A	ø1	C / Z
ELAM0113	180	ø20	1401
ELAM0114	180	ø30	1435
ELAM0115	210	ø20	1408
ELAM0116	210	ø30	1442
ELAM0117	240	ø20	1418
ELAM0118	240	ø30	1452

MOVIMENTI POSSIBILI / POSSIBLE MOVEMENTS / MOUVEMENTS POSSIBLE
MÖGLICHE BEWEGUNGEN / MOVIMIENTOS POSIBLES

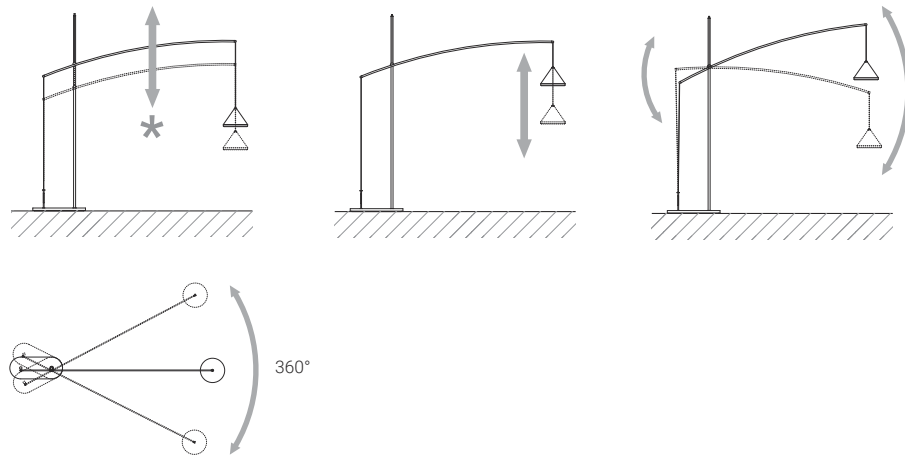

ESEMPI DI INSTALLAZIONE / EXAMPLES OF INSTALLATION / EXEMPLES D'INSTALLATION
INSTALLATIONSBEISPIELE / EJEMPLOS DE INSTALACIÓN

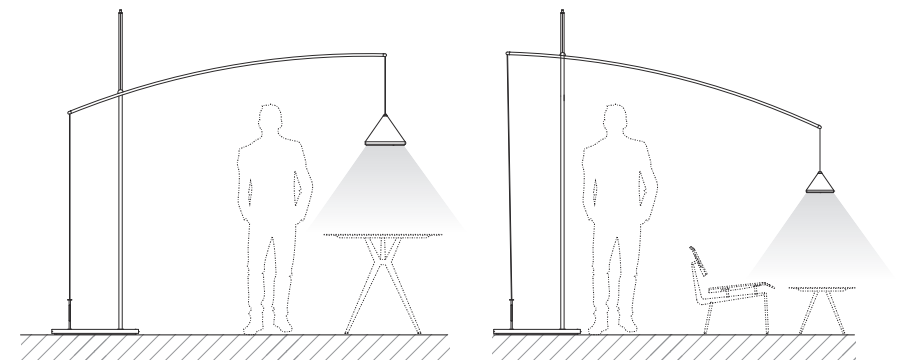

regolazioni da effettuare in fase di installazione
adjustments to make during installation
réglages à effectuer lors de l'installation
Bei der Installation vorzunehmende Regulierungen
ajustes a realizar durante la instalación



lunghezza filo
length of wire
longueur de fil
Schnurlänge
Longitud cable



informazioni e ricambi a pg.233
information and spare parts on page 233
informations et pièces de rechange p. 233
Infos und Ersatzteile auf S.233
Información y recambios en pág.233

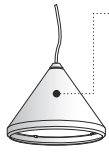

C alluminio verniciato/painted aluminium/aluminium peint
lackierter Aluminium/aluminio pintado

- | | |
|---------------------------------|-----------------------------|
| C12 bianco/white | C08 nero/black |
| C21 seta/silk | C29 bronzo/bronze |
| C23 corda/ecru | C37 rame/copper |
| C30 ghisa/cast-iron | C38 titanio/titanium |
| C14 antracite/anthracite | |

**LAMPADA A SOFFITTO CON CONTRAPPESO / CEILING LAMP WITH COUNTERWEIGHT / PLAFONNIER AVEC CONTREPOIDS
DECKENLAMPE MIT GEGENGEWICHT / LÁMPARA DE TECHO CON CONTRAPESO**

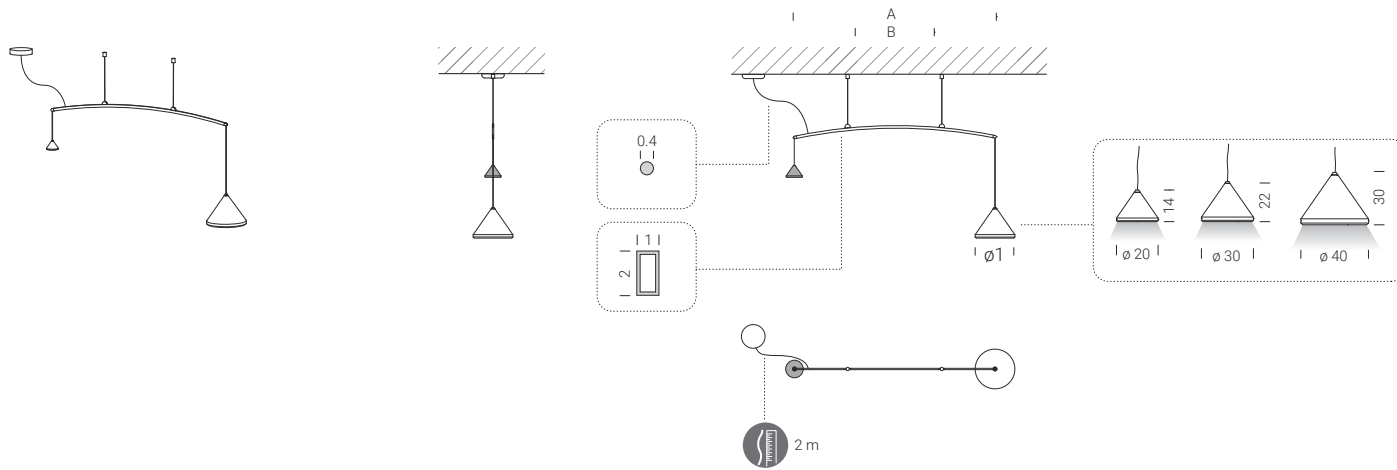

	A	B	ø1	C
ELAM0119	130	60	ø20	798
ELAM0120	130	60	ø30	836
ELAM0121	130	60	ø40	927
ELAM0122	160	80	ø20	802
ELAM0123	160	80	ø30	839
ELAM0124	160	80	ø40	931

MOVIMENTI POSSIBILI / POSSIBLE MOVEMENTS / MOUVEMENTS POSSIBLE
MÖGLICHE BEWEGUNGEN / MOVIMIENTOS POSIBLES

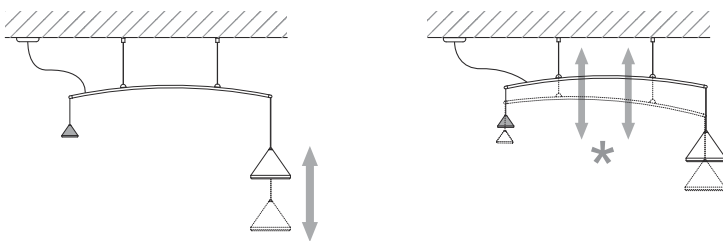

ESEMPI DI INSTALLAZIONE / EXAMPLES OF INSTALLATION / EXEMPLES D'INSTALLATION
INSTALLATIONSBEISPIELE / EJEMPLOS DE INSTALACIÓN

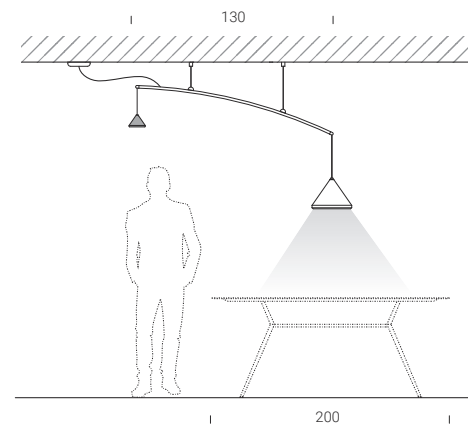

regolazioni da effettuare in fase di installazione
adjustments to make during installation
réglages à effectuer lors de l'installation
Bei der Installation vorzunehmende Regulierungen
ajustes a realizar durante la instalación



lunghezza filo
length of wire
longueur de fil
Schnurlänge
Longitud cable



informazioni e ricambi a pg.233
information and spare parts on page 233
informations et pièces de rechange p. 233
Infos und Ersatzteile auf S.233
Información y recambios en pág.233

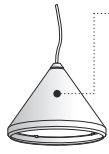

C alluminio verniciato/painted aluminium/aluminium peint
lackierter Aluminium/aluminio pintado

C12 bianco/white **C08** nero/black
C21 seta/silk **C29** bronzo/bronze
C23 corda/ecru **C37** rame/copper
C30 ghisa/cast-iron **C38** titanio/titanium
C14 antracite/anthracite

**LAMPADA MOBILE CON CONTRAPPESO / MOBILE LAMP WITH COUNTERWEIGHT / LAMPE MOBILE AVEC CONTREPOIDS
BEWEGLICHE LAMPE MIT GEGENGEWICHT / LÁMPARA MÓVIL CON CONTRAPESO**

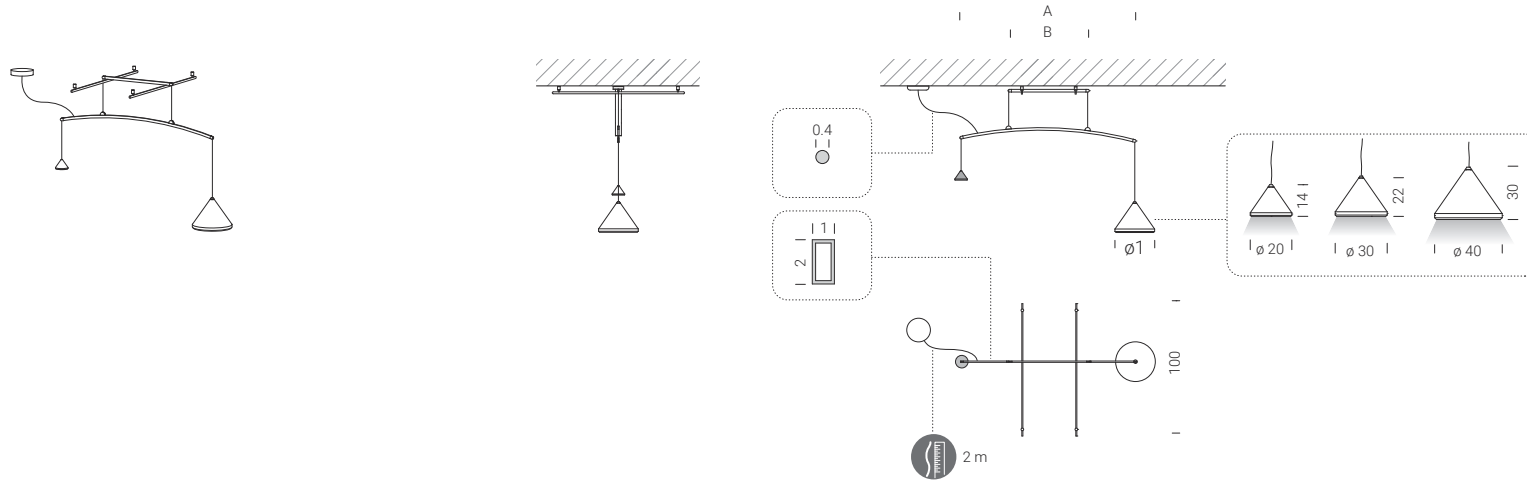

	A	B	ø1	C
ELAM0125	130	60	ø20	966
ELAM0126	130	60	ø30	1004
ELAM0127	130	60	ø40	1096
ELAM0128	160	80	ø20	970
ELAM0129	160	80	ø30	1008
ELAM0130	160	80	ø40	1100

MOVIMENTI POSSIBILI / POSSIBLE MOVEMENTS / MOUVEMENTS POSSIBLE
MÖGLICHE BEWEGUNGEN / MOVIMIENTOS POSIBLES

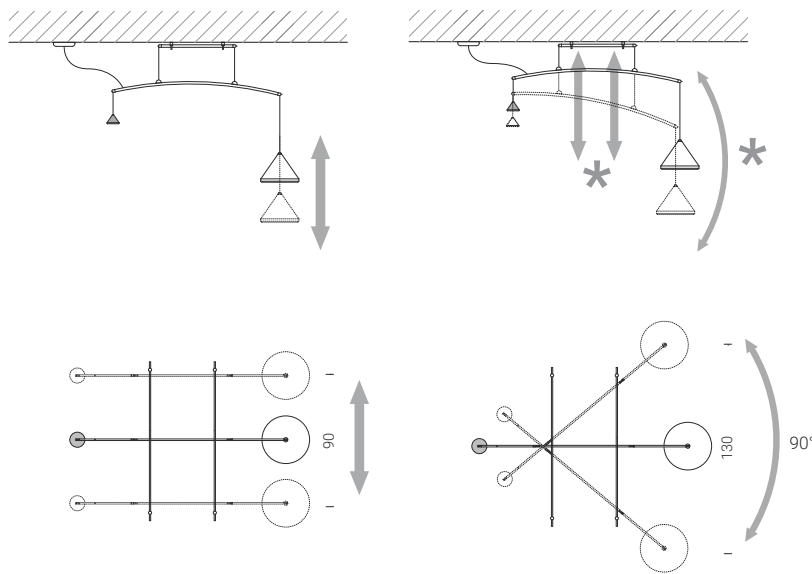

ESEMPI DI INSTALLAZIONE / EXAMPLES OF INSTALLATION / EXEMPLES D'INSTALLATION
INSTALLATIONSBEISPIELE / EJEMPLOS DE INSTALACIÓN

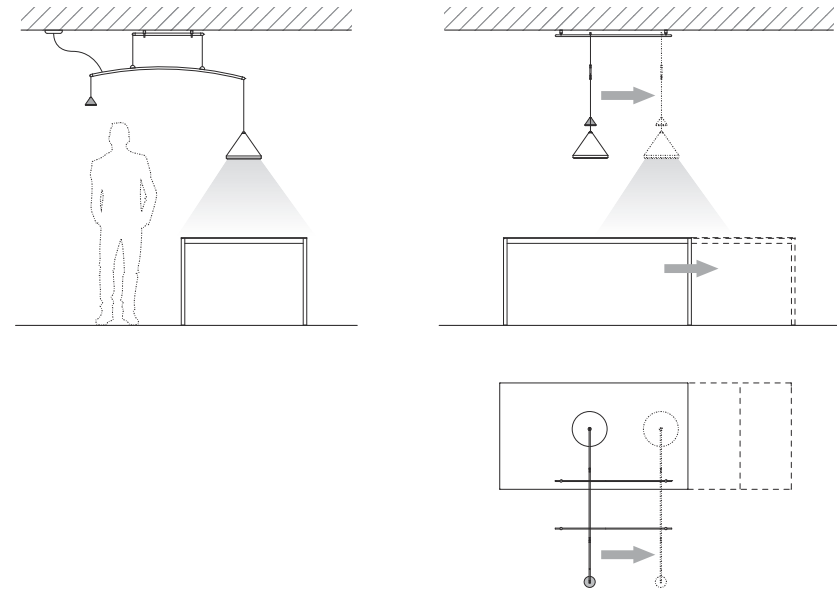

regolazioni da effettuare in fase di installazione
adjustments to make during installation
réglages à effectuer lors de l'installation
Bei der Installation vorzunehmende Regulierungen
ajustes a realizar durante la instalación



lunghezza filo
length of wire
longueur de fil
Schnurlänge
Longitud cable



informazioni e ricambi a pg.233
information and spare parts on page 233
informations et pièces de rechange p. 233
Infos und Ersatzteile auf S.233
Información y recambios en pág.233

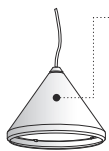

C alluminio verniciato/painted aluminium/aluminium peint
lackierter Aluminium/aluminio pintado

C12 bianco/white **C08** nero/black
C21 seta/silk **C29** bronzo/bronze
C23 corda/ecru **C37** rame/copper
C30 ghisa/cast-iron **C38** titanio/titanium
C14 antracite/anthracite

**LAMPADA DOPPIA A SOFFITTO / DOUBLE CEILING LAMP / PLAFONNIER DOUBLE
DOPPELTE DECKENLAMPE / LÁMPARA DOBLE DE TECHO**

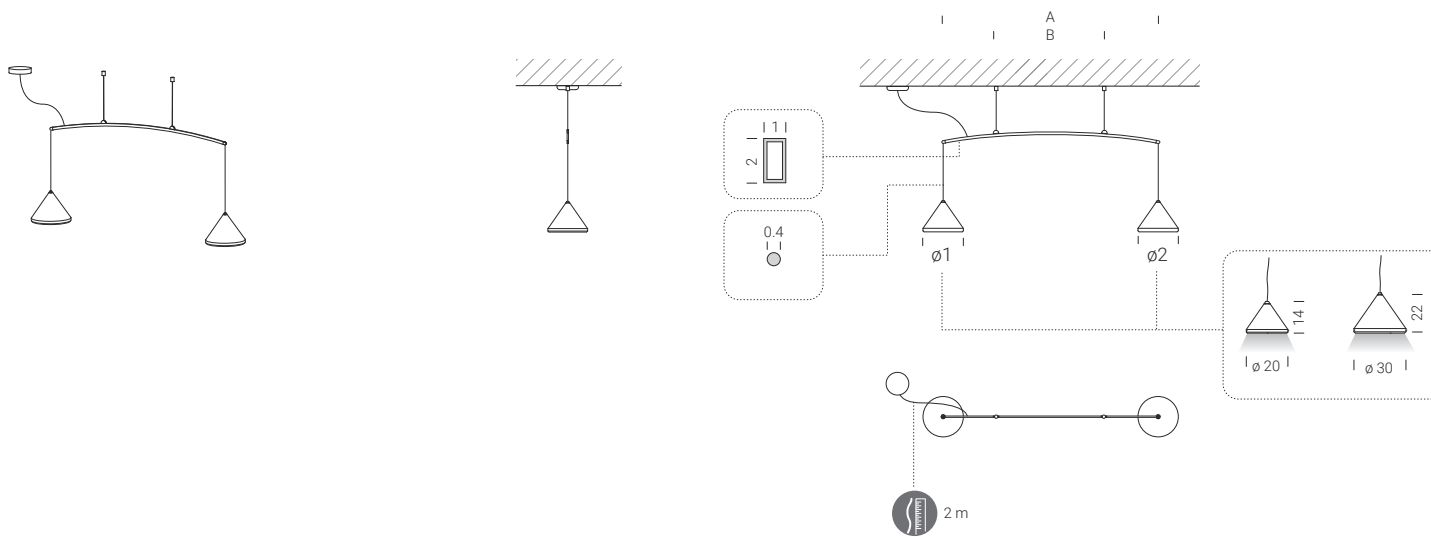

	A	B	ø1	ø2	C
ELAM0131	130	60	ø20	ø20	972
ELAM0132	130	60	ø20	ø30	1010
ELAM0133	130	60	ø30	ø30	1048
ELAM0134	160	80	ø20	ø20	976
ELAM0135	160	80	ø20	ø30	1014
ELAM0136	160	80	ø30	ø30	1052

MOVIMENTI POSSIBILI / POSSIBLE MOVEMENTS / MOUVEMENTS POSSIBLE
MÖGLICHE BEWEGUNGEN / MOVIMIENTOS POSIBLES

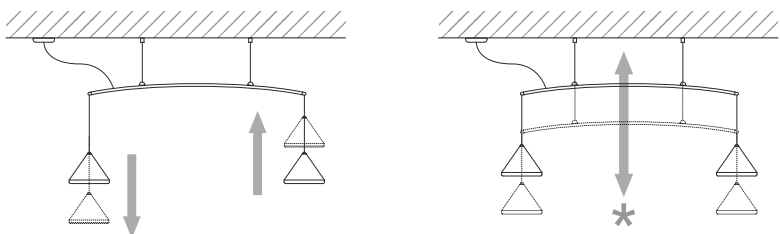

ESEMPI DI INSTALLAZIONE / EXAMPLES OF INSTALLATION / EXEMPLES D'INSTALLATION
INSTALLATIONSBEISPIELE / EJEMPLOS DE INSTALACIÓN

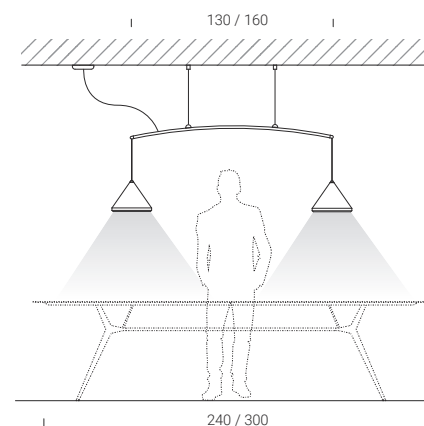

*

regolazioni da effettuare in fase di installazione
adjustments to make during installation
réglages à effectuer lors de l'installation
Bei der Installation vorzunehmende Regulierungen
ajustes a realizar durante la instalación



lunghezza filo
length of wire
longueur de fil
Schnurlänge
Longitud cable



informazioni e ricambi a pg.233
information and spare parts on page 233
informations et pièces de rechange p. 233
Infos und Ersatzteile auf S.233
Información y recambios en pág.233

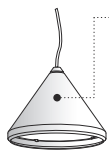

C alluminio verniciato/painted aluminium/aluminium peint
lackierter Aluminium/aluminio pintado

- | | |
|---------------------------------|-----------------------------|
| C12 bianco/white | C08 nero/black |
| C21 seta/silk | C29 bronzo/bronze |
| C23 corda/ecru | C37 rame/copper |
| C30 ghisa/cast-iron | C38 titanio/titanium |
| C14 antracite/anthracite | |

**LAMPADA MOBILE DOPPIA / DOUBLE MOBILE LAMP / LAMPE MOBILE DOUBLE
BEWEGLICHE DOPPELLAMPE / LÁMPARA MÓVIL DOBLE**

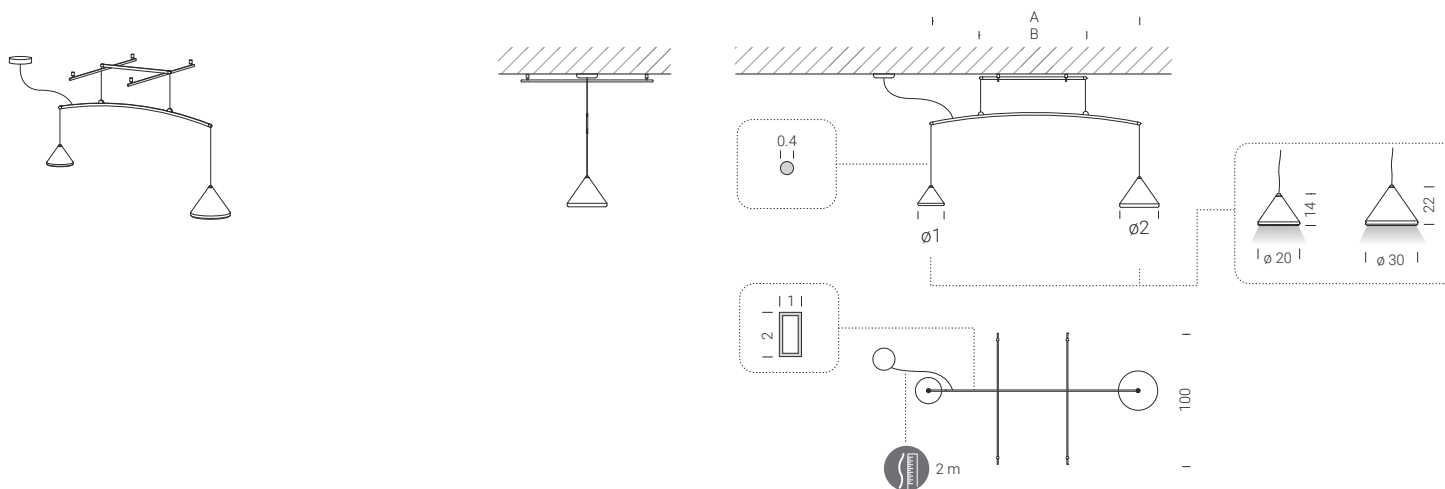

	A	B	ø1	ø2	C
ELAM0137	130	60	ø20	ø20	1141
ELAM0138	130	60	ø20	ø30	1179
ELAM0139	130	60	ø30	ø30	1217
ELAM0140	160	80	ø20	ø20	1151
ELAM0141	160	80	ø20	ø30	1189
ELAM0142	160	80	ø30	ø30	1227

MOVIMENTI POSSIBILI / POSSIBLE MOVEMENTS / MOUVEMENTS POSSIBLE
MÖGLICHE BEWEGUNGEN / MOVIMIENTOS POSIBLES

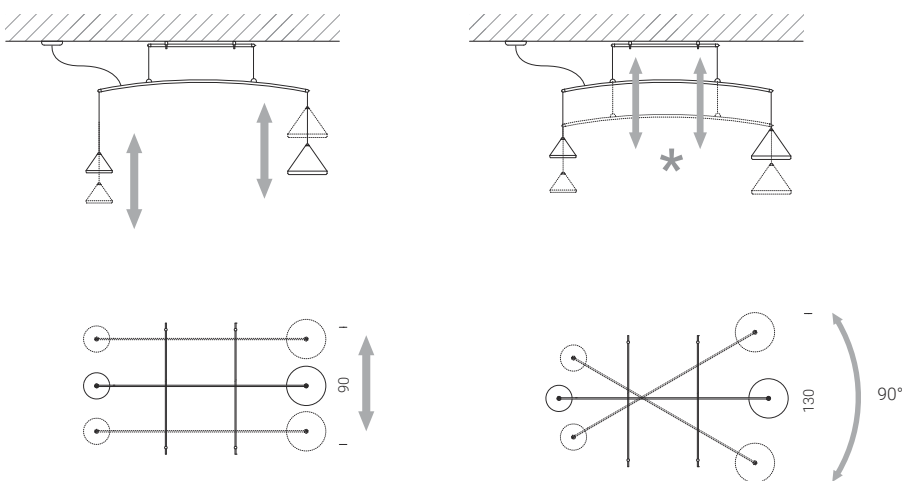

ESEMPI DI INSTALLAZIONE / EXAMPLES OF INSTALLATION / EXEMPLES D'INSTALLATION
INSTALLATIONSBEISPIELE / EJEMPLOS DE INSTALACIÓN

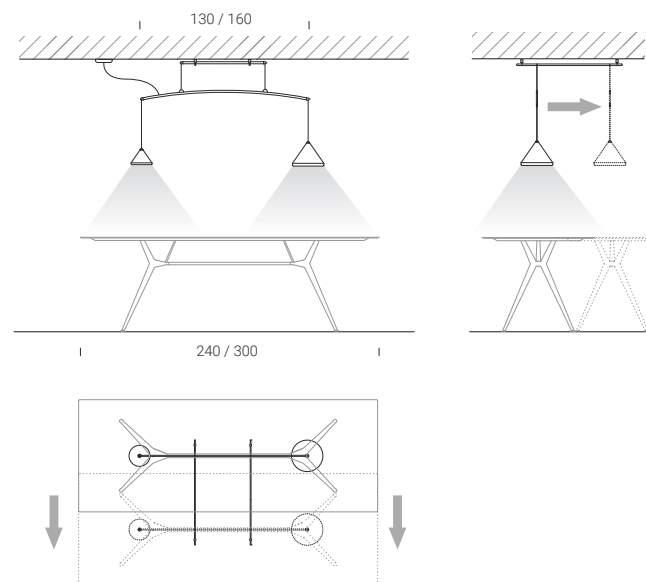

regolazioni da effettuare in fase di installazione
adjustments to make during installation
réglages à effectuer lors de l'installation
Bei der Installation vorzunehmende Regulierungen
ajustes a realizar durante la instalación



lunghezza filo
length of wire
longueur de fil
Schnurlänge
Longitud cable



informazioni e ricambi a pg.233
information and spare parts on page 233
informations et pièces de rechange p. 233
Infos und Ersatzteile auf S.233
Información y recambios en pág.233

C alluminio verniciato/painted aluminium/aluminium peint lackierter Aluminium/aluminio pintado

C12 bianco/white	C08 nero/black
C21 seta/silk	C29 bronzo/bronze
C23 corda/ecru	C37 rame/copper
C30 ghisa/cast-iron	C38 titanio/titanium
C14 antracite/anthracite	

C acciaio verniciato/painted steel/acier peint lackierter Stahl/acero pintado

C12 bianco/white	C08 nero/black
C21 seta/silk	C29 bronzo/bronze
C23 corda/ecru	C37 rame/copper
C30 ghisa/cast-iron	C38 titanio/titanium
C14 antracite/anthracite	

Z marmo/marble/marbre
Marmor/mármol

Z01 bianco Carrara/Carrara white
Z02 nero Marquìña/black Marquìña
Z03 verde Alpi/Alpi green

**LAMPADA A FILO / PENDANT LAMP / LAMPE À FIL
LAMPE MIT SCHNUR / LÁMPARA DE CABLE**

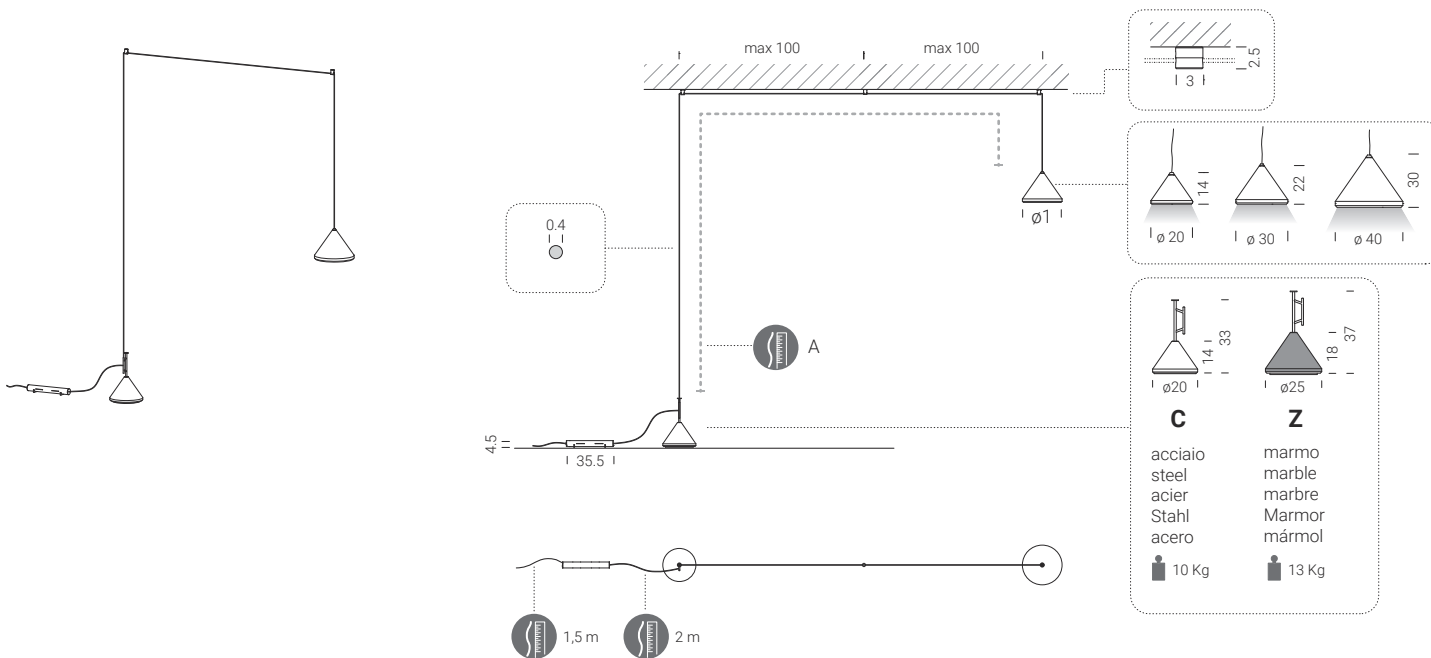

	A	ø1		C	Z
ELAM0143	6 m	ø 20	2	896	1577
ELAM0144	6 m	ø 30	2	934	1610
ELAM0145	6 m	ø 40	2	1026	1693
ELAM0146	8 m	ø 20	3	948	1623
ELAM0147	8 m	ø 30	3	986	1657
ELAM0148	8 m	ø 40	3	1077	1739
ELAM0149	10 m	ø 20	4	999	1669
ELAM0150	10 m	ø 30	4	1037	1703
ELAM0151	10 m	ø 40	4	1129	1785

**SUPPORTO ADDIZIONALE/ADDITIONAL SUPPORT
SUPPORT ADDITIONNEL
ZUSÄTZLICHER UNTERSTÜTZUNG
SOPORTE ADICIONAL**

	C
EACL0101	39

CONTRAPPESO

MOVIMENTI POSSIBILI / POSSIBLE MOVEMENTS / MOUVEMENTS POSSIBLE
MÖGLICHE BEWEGUNGEN / MOVIMIENTOS POSIBLES

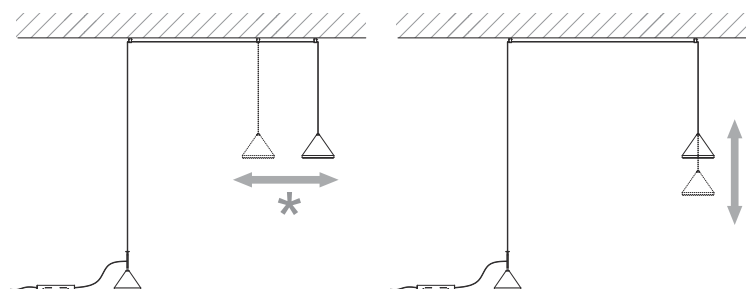

ESEMPI DI INSTALLAZIONE / EXAMPLES OF INSTALLATION / EXEMPLES D'INSTALLATION
INSTALLATIONSBEISPIELE / EJEMPLOS DE INSTALACIÓN

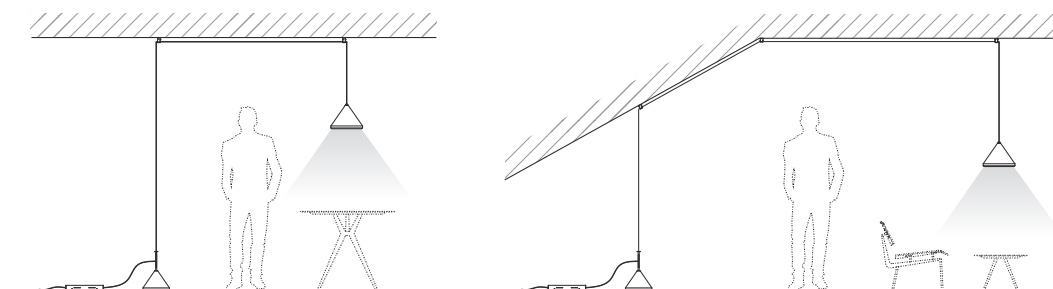

regolazioni da effettuare in fase di installazione
adjustments to make during installation
réglages à effectuer lors de l'installation
Bei der Installation vorzunehmende Regulierungen
ajustes a realizar durante la instalación

Ø
lunghezza filo
length of wire
longueur de fil
Schnurlänge
Longitud cable

?
informazioni e ricambi a pg.233
information and spare parts on page 233
informations et pièces de rechange p. 233
Infos und Ersatzteile auf S.233
Información y recambios en pág.233

Ø
numero di supporti inclusi
number of supports included
nombre de supports inclus
Anzahl der enthaltenen Halterungen
número de soportes incluidos

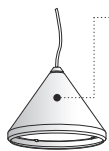

C alluminio verniciato/painted aluminium/aluminium peint
lackierter Aluminium/aluminio pintado

C12 bianco/white **C08** nero/black
C21 seta/silk **C29** bronzo/bronze
C23 corda/ecru **C37** rame/copper
C30 ghisa/cast-iron **C38** titanio/titanium
C14 antracite/anthracite

**LED DI RICAMBIO / SPARE LED / LED DE RECHANGE
ERSATZ-LED / LED DE RECAMBIO**

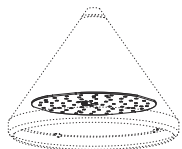

EACL0102	ø20-ø30	67
EACL0103	ø40	97

**TRASFORMATORE DI RICAMBIO / SPARE TRANSFORMER
TRANSFORMATEUR DE RECHANGE / ERSATZ-TRAFO
TRANSFORMADOR DE RECAMBIO**



disponibile per: ELAM0101 ÷ ELAM0118
available for: ELAM0143 ÷ ELAM0151

EACL0104	109
-----------------	-----

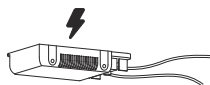

disponibile per: ELAM0119 ÷ ELAM0142
available for:

EACL0105	122
-----------------	-----

**PARALUME DI RICAMBIO / SPARE LAMP SHADE / ABAT-JOUR DE RECHANGE
ERSATZ-LAMPENSCHIRM / PANTALLA DE RECAMBIO**

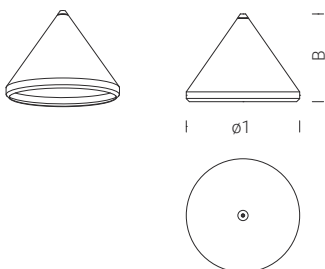

	ø1	B	C
EACL0106	ø20	14	95
EACL0107	ø30	22	124
EACL0108	ø40	30	176

**SCHEMA CONO DI LUCE / CONE OF LIGHT DIAGRAM / SCHÉMA CÔNE DE LUMIÈRE
LICHTKEGELPLAN / ESQUEMA CONO DE LUZ**

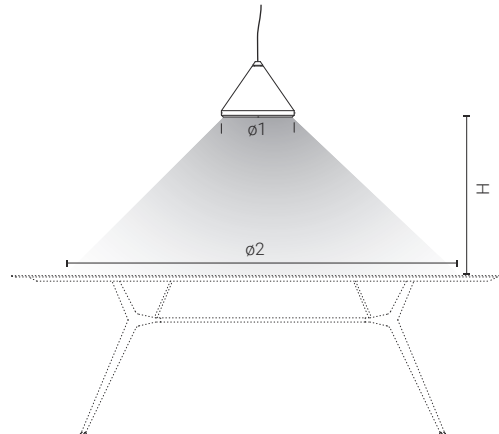

ø1	H	ø2
ø20	70	ø180
ø20	90	ø220
ø30	70	ø200
ø30	90	ø240
ø40	70	ø240
ø40	90	ø300

**LAMPADA Ø20-Ø30 / CEILING LAMP Ø20-Ø30 / LAMPE Ø20-Ø30
LAMPE Ø20-Ø30 / LÁMPARA Ø20-Ø30**

Led Module: SMD LED MOUNTED ON MODULE CLE 160 mm. ADV4
 Lumen: 3100 lm
 Power: 650 mA
 INPUT: 220 – 240 V | 50/60 Hz
 Color temperature: 3000 K
 Dimming range 1 – 100 %
 CRI: >80

**LAMPADA Ø40 / CEILING LAMP Ø40 / LAMPE Ø40
LAMPE Ø40 / LÁMPARA Ø40**

Led Module: SMD LED MOUNTED ON MODULE CLE 315 mm. ADV4
 Lumen: 4200 lm
 Power: 900 mA
 INPUT: 220 – 240 V | 50/60 Hz
 Color temperature: 3000 K
 Dimming range 1 – 100 %
 CRI: >80

CONNECT

tv dimension: 40" - 85"

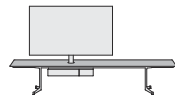

SUPPORTO PENSATO PER INSTALLARE LE TV DI NUOVA GENERAZIONE A PARETE O IN CENTRO STANZA CON LA MASSIMA FLESSIBILITÀ. IL SISTEMA DI INTEGRAZIONE CAVI STUDIATO DA EXTENDO CONSENTE DI NASCONDERE COMPLETAMENTE I CAVI LASCIANDO LIBERTÀ DI ROTAZIONE DI 360° DELLA TV. IL SUPPORTO ROTANTE E IL CONTENIMENTO DI APPARATI MULTIMEDIALI NELLA PARTE SOTTOSTANTE SONO ACCESSORI.

This is a TV support column designed to host new generation TV installations either mounted on the wall or in the centre of the room with the utmost flexibility. The cable integration system designed by extendo makes it possible to completely conceal cables enabling the TV to freely rotate a full 360°. The turntable swivel base and the multimedia device cable containment system in the lower part of the support column are accessories.

Support conçu pour installer les téléviseurs de nouvelle génération au mur ou au centre de la pièce avec une flexibilité maximale. Le système d'intégration des câbles, conçu par extendo, permet de cacher complètement les câbles en laissant la liberté de rotation de 360° du téléviseur. Le support pivotant et le récipient pour appareils multimédias dans la partie en dessous sont des accessoires.

Fernsehalterung für die Installation von TV-Geräten der neuesten Generation an der Wand oder in der Raummitte, für maximale Flexibilität bei der Positionierung. Dank der von extendo entwickelten, integrierten Kabelführung lassen sich die Gerätekabel völlig verstecken, wobei das Gerät um 360 Grad schwenkbar bleibt. Die Drehhalterung und die unterhalb anzubringenden Fächer für Multimedia-Geräte sind als Zubehör erhältlich.

Soporte pensado para instalar televisores de nueva generación en la pared o en una posición central en el ambiente, con la máxima flexibilidad. El sistema de integración de cables estudiado por extendo, permite ocultar los cables por completo, dejando libertad de rotación de 360° para el televisor. Cuenta con accesorios en la parte de abajo: un soporte giratorio y un espacio para posicionar dispositivos multimedia.



i cavi della TV e di eventuali unità multimediali sono completamente nascosti.

the TV and multimedia unit wires are completely hidden.

les fils de la TV et des unités multimédias sont complètement dissimulés.

Die Kabel des Fernsehers und der Multimedia sind vollkommen unsichtbar.

los cables de la TV y de los sistemas multimedia quedan completamente ocultos.



supporto monitor universale per TV da 40 a 85 pollici.

universal monitor support for TV from 40 to 85 inches.

support moniteur universel pour TV de 40 à 85 pouces.

Universal-Monitor-Halter für TV von 40 bis 85 Zoll.

soporte de monitor universal para TV de 40 a 85 pulgadas.

- acciaio verniciato/painted steel/acier peint
lackierter Stahl/acero pintado
- C12** bianco/white
C21 seta/silk
C23 corda/ecru
C30 ghisa/cast-iron
C14 antracite/anthracite
C08 nero/black
C18 verde/green
C26 corten/corten
C29 bronzo/bronze
C37 rame/copper
C38 titanio/titanium

- ceramica/ceramic/c eramique
Keramik/cer mico
- S05** antracite/anthracite
S06 nero/black
S07 porfido/porfido
S08 cardoso/cardoso

- HPL POLARIS®
- L03** bianco/white
L10 grigio chiaro/light grey
L11 grigio scuro/dark grey
- HPL FENIX®
- L08** grigio Londra/London grey
L06 nero/black

- HPL+ cemento/concrete/ciment
zement/cemento
- D01** bianco calce/lime white
D02 grigio Portland/Portland grey
D03 nero/black
- HPL+ metallo/metal/m tal/Metall/metal
- C31** ottone/brass
C32 ottone scuro/dark brass
C35 inox/inox
C36 inox scuro/dark inox

- HPL+ legno/wood/bois/Holz/madera
- Y36** rovere/oak
Y34 noce/walnut
Y37 rovere affumicato/smoked oak
Y39 frassino nero/black ash
Y40 frassino argilla/clay ash
- HPL+ ecotouch
- N01** sabbia/sand
N02 basalto/basalt

CONSOLLE MULTIMEDIA / MULTIMEDIA CONSOLE / CONSOLES MULTIM DIA MULTIMEDIA-KONSOLEN / CONSOLAS MULTIMEDIA

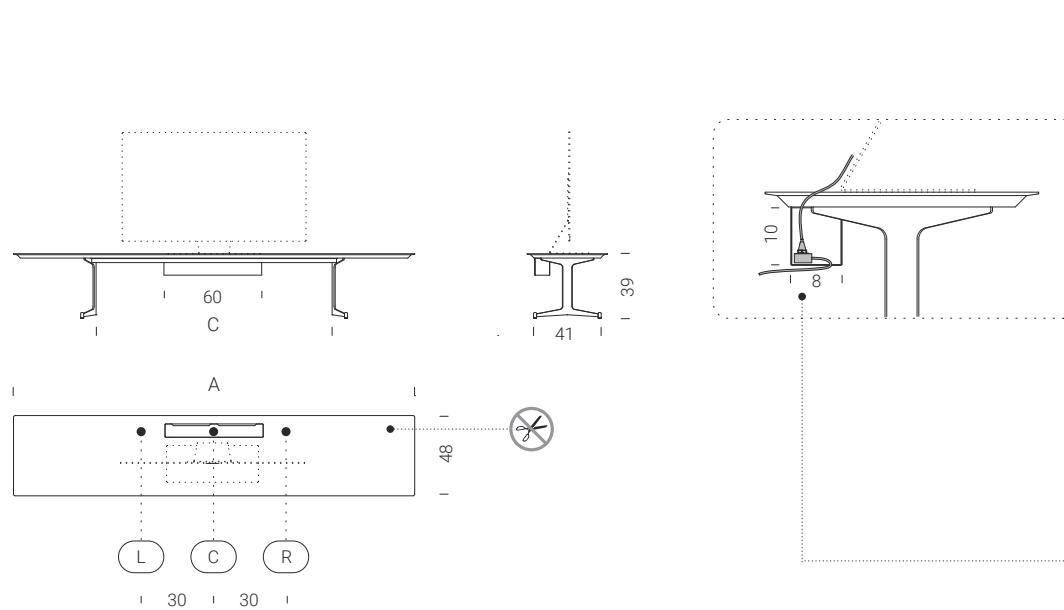

	A x B	C	S05 S06 S07 S08	L03 L06	L08 L10 L11	D01 D02 D03	C31 C32 C35 C36	Y36 Y34 Y37 Y39 Y40	N01 N02
TCPT0008	120 x 48	77	1342	1093	1125	1277	1629	1260	1193
TCPT0009	140 x 48	77	1432	1167	1204	1369	1771	1351	1272
TCPT0010	160 x 48	102	1582	1289	1354	1538	1997	1495	1415
TCPT0011	180 x 48	102	1649	1341	1399	1591	2106	1594	1479
* TCPT0012	200 x 48	142	1830	1501	1572	1788	2339	1764	1652
* TCPT0013	220 x 48	142	1945	1595	1674	1904	2655	1881	1754
* TCPT0014	240 x 48	142	2037	1649	1734	1973	2776	1951	1809

- * ordinabile in posizione L (sinistra), R (destra), C (centrale).
available in the following positions: L (left), R (right), C (central).
peut  tre command  en position L (gauche), R (droite), C (centrale).
aufstellbar in Position L (links), R (rechts), C (Mitte).
disponible en posici n L (izquierda), R (derecha), C (central).

cesto in acciaio e copertura magnetica nelle finiture della consolle.
steel basket and magnetic cover in the console finishings.
panier en acier et couvercle magn tique dans les m mes finitions que la consoles.
Stahlkorb und Magnetabdeckung in der Konsolenausf hrung.
cesto de acero y cubierta magn tica en los acabados de la consolas.



i cavi della TV e di eventuali unit  multimediali sono completamente nascosti
the TV and multimedia unit wires are completely hidden
les fils de la TV et des unit s multim dias sont compl tement dissimul s
die Kabel des Fernsehers und der Multimedia sind vollkommen unsichtbar
los cables de la TV y de los sistemas multimedia quedan completamente ocultos



supporto monitor universale per TV da 40 a 85 pollici.
universal monitor support for TV from 40 to 85 inches.
support moniteur universel pour TV de 40   85 pouces.
erh ltliches Zubeh r auf pg.237
soporte de monitor universal para TV de 40 a 85 pulgadas.



accessori disponibili a pg.237
accessories available on pg.237
accessoires disponibles pg.237
erh ltliches Zubeh r auf pg.237
accesorios disponibles en pg.237



non riducibili
non-reducible items
aucune r duction possible
nicht verk rzbare
no reducibles

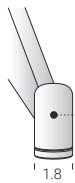

acciaio verniciato/painted steel/acier peint
lackierter Stahl/acero pintado

- C12** bianco/white
- C21** seta/silk
- C23** corda/ecru
- C30** ghisa/cast-iron
- C14** antracite/anthracite
- C08** nero/black
- C18** verde/green
- C26** corten/corten
- C29** bronzo/bronze
- C37** rame/copper
- C38** titanio/titanium



ceramica/ceramic/c eramique
Keramik/cer mico

- S05** antracite/anthracite
- S06** nero/black
- S07** porfido/porfido
- S08** cardoso/cardoso



HPL POLARIS®

- L03** bianco/white
- L10** grigio chiaro/light grey
- L11** grigio scuro/dark grey

HPL FENIX®

- L08** grigio Londra/London grey
- L06** nero/black



HPL+ cemento/concrete/ciment
zement/cemento

- D01** bianco calce/lime white
- D02** grigio Portland/Portland grey
- D03** nero/black
- HPL+ metallo/metal/m tal/Metall/metal**
- C31** ottone/brass
- C32** ottone scuro/dark brass
- C35** inox/inox
- C36** inox scuro/dark inox



HPL+ legno/wood/bois/Holz/madera

- Y36** rovere/oak
- Y34** noce/walnut
- Y37** rovere affumicato/smoked oak
- Y39** frassino nero/black ash
- Y40** frassino argilla/clay ash
- HPL+ ecotouch**
- N01** sabbia/sand
- N02** basalto/basalt

CONSOLLE MULTIMEDIA CON SUPPORTO ORIENTABILE 360° / MULTIMEDIA CONSOLE WITH 360° ADJUSTABLE SUPPORT
CONSOLES MULTIM DIA AVEC SUPPORT ORIENTABLE   360° / MULTIMEDIA-KONSOLEN MIT VERSTELLBARER ST TZE 360°
CONSOLAS MULTIMEDIA CON SOPORTE ORIENTABLE A 360°

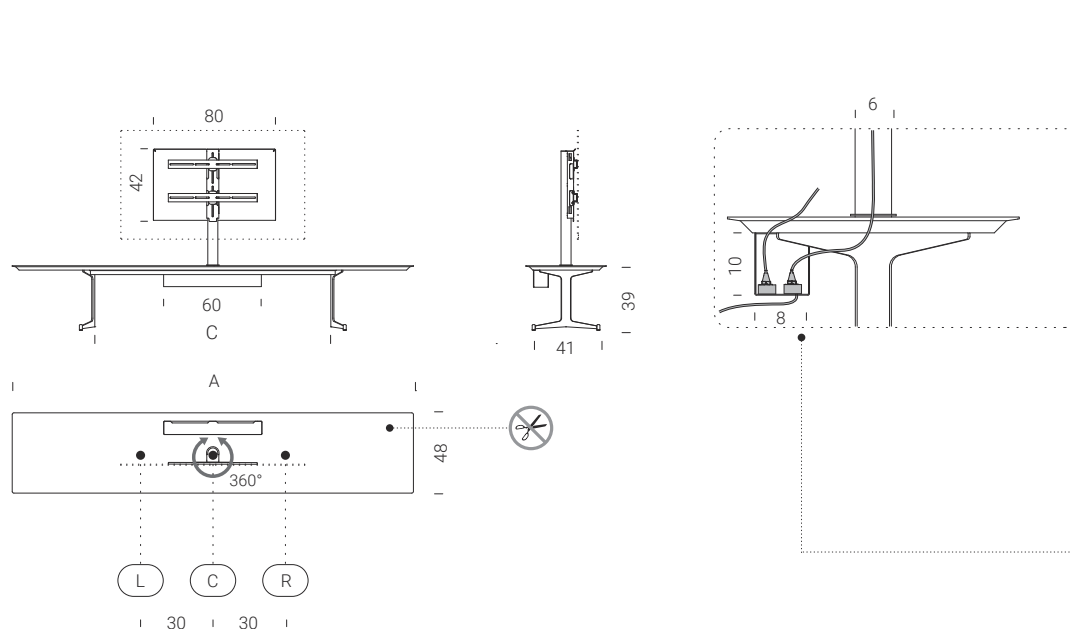

	A x B	C	S05	S06	S07	S08	L03	L06	L08	L10	L11	D01	D02	D03	C31	C32	C35	C36	Y36	Y34	Y37	Y39	Y40	N01	N02
TCPT0001	120 x 48	77	1909	1558	1602	1819	2166	1788	1735																
TCPT0002	140 x 48	77	2000	1631	1683	1911	2308	1880	1813																
TCPT0003	160 x 48	102	2127	1778	1821	2068	2540	2035	1957																
TCPT0004	180 x 48	102	2472	2170	2119	2206	2701	2172	2082																
* TCPT0005	200 x 48	142	2442	2032	2103	2389	2948	2352	2254																
* TCPT0006	220 x 48	142	2541	2094	2172	2468	3206	2431	2318																
* TCPT0007	240 x 48	142	2636	2171	2256	2564	3365	2527	2400																

* ordinabile in posizione L (sinistra), R (destra), C (centrale).
 available in the following positions: L (left), R (right), C (central).
 peut  tre command  en position L (gauche), R (droite), C (centrale).
 aufstellbar in Position L (links), R (rechts), C (Mitte).
 disponible en posici n L (izquierda), R (derecha), C (central).

cesto in acciaio e copertura magnetica nelle finiture della console.
 steel basket and magnetic cover in the console finishings.
 panier en acier et couvercle magn tique dans les m mes finitions que la consoles.
 Stahlkorb und Magnetabdeckung in der Konsolenausf hrung.
 cesto de acero y cubierta magn tica en los acabados de las consolas.



i cavi della TV e di eventuali unit  multimediali sono completamente nascosti
 the TV and multimedia unit wires are completely hidden
 les fils de la TV et des unit s multim dias sont compl tement dissimul s
 die Kabel des Fernsehers und der Multimedia sind vollkommen unsichtbar
 los cables de la TV y de los sistemas multimedia quedan completamente ocultos



supporto monitor universale per TV da 40 a 85 pollici.
 universal monitor support for TV from 40 to 85 inches.
 support moniteur universel pour TV de 40   85 pouces.
 Universal-Monitor-Halter f r TV von 40 bis 85 Zoll.
 soporte de monitor universal para TV de 40 a 85 pulgadas.



accessori disponibili a pg.237
 accessories available on pg.237
 accessoires disponibles pg.237
 erh ltliches Zubeh r auf pg.237
 accesorios disponibles en pg.237



non riducibili
 non-reducible items
 aucune r duction possible
 nicht verk rztbar
 no reducibles



ceramica/ceramic/c eramique
Keramik/cer mico

- S05** antracite/anthracite
- S06** nero/black
- S07** porfido/porfido
- S08** cardoso/cardoso



HPL POLARIS®

- L03** bianco/white
- L10** grigio chiaro/light grey
- L11** grigio scuro/dark grey



HPL FENIX®

- L08** grigio Londra/London grey
- L06** nero/black



HPL+ cemento/concrete/ciment
zement/cemento

- D01** bianco calce/lime white
- D02** grigio Portland/Portland grey
- D03** nero/black



HPL+ metallo/metal/m tal/Metall/metal

- C31** ottone/brass
- C32** ottone scuro/dark brass
- C35** inox/inox
- C36** inox scuro/dark inox

**CONTENITORE MULTIMEDIA / MULTIMEDIA HOLDER / MEUBLE MULTIM DIA
MULTIMEDIA-BEH LTER / CONTENEDOR MULTIMEDIA**

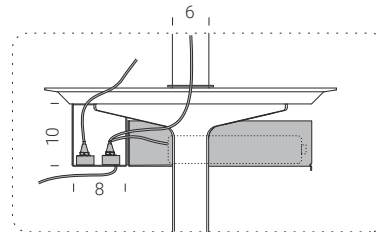
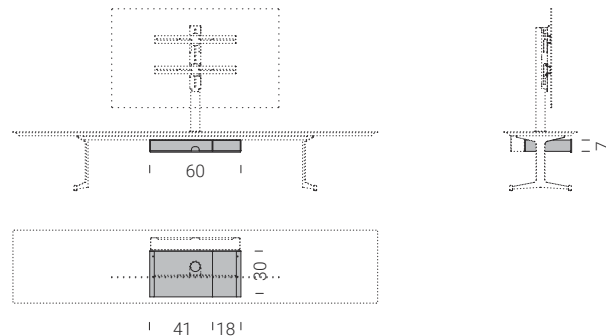

	A x B x C	
TACC0002	60 x 30 x 7	206

scocca in acciaio
steel body
coque en acier
Stahlaufbau
chapa de acero

CASSETTI / DRAWERS / TIROIRS / SCHUBLADEN / CAJ NES

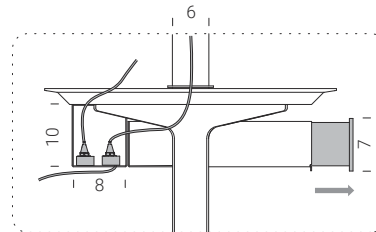
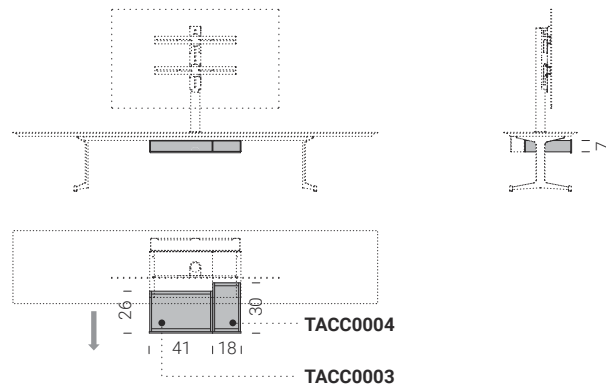

	A x B x C	
TACC0003	41 x 26 x 7	129
TACC0004	18 x 30 x 7	85

frontale nella finitura della consolle
front in console finishings
fa ade dans la m me finition que la console
Vorderseite in der Konsolenausf hrung
frontal en el acabado de la consola

VASSOI / TRAYS / PLATEAUX / TABLETS / BANDEJAS

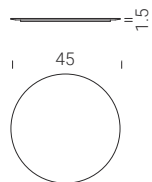

	S05	S06	S07	S08	L03	L06	L08	L10	L11	D01	D02	D03	C31	C32	C35	C36
SACC0007	45 x 1.5	190	165	180	205	245										

vedi catalogo a pg.172 / refer to catalogue pg.172
Voir catalogue pg. 172 / siehe Katalog auf pg.172
v ase pg.172 del cat logo

APOLLO

tv dimension: 40" - 65"



DESIDERAVAMO DISEGNARE UN SUPPORTO CHE SI INTEGRASSE AL MEGLIO CON IL DESIGN ESSENZIALE DEGLI ULTIMI MODELLI TV. APOLLO PUR ESSENDO COMPOSTO DA POCHI ELEMENTI CHE NE EVIDENZIANO LA PUREZZA GEOMETRICA, CONSENTE LA ROTAZIONE DI 360°, L'OCCULTAMENTO DEI CAVI E LA POSSIBILITÀ DI AGGIUNGERE ACCESSORI PORTA DECODER E SOUND BAR.

We had the intention to design a TV support column that integrates at best with the essential design of the latest TV models. Although Apollo consists of only a few elements that enhance its geometrical purity, it rotates 360°, the concealing of cables along with the possibility to add TV decoder and sound bar support accessories.

Nous souhaitons dessiner un support qui s'intègre au mieux avec le design essentiel des derniers modèles de téléviseurs. Apollo, même s'il est composé de peu d'éléments qui mettent en évidence sa pureté géométrique, permet la rotation de 360°, la dissimulation des câbles et la possibilité d'ajouter des accessoires comme le portedécodeur et la barre audio.

Unser Anliegen bestand darin, einen Fernsehständer zu entwerfen, der optimal auf das essentielle Design der neuesten TV-Modelle abgestimmt ist. Apollo setzt auf einen essentiellen Aufbau aus wenigen Elementen und besticht durch eine schlichte Optik. Er erlaubt eine Drehung des Geräts um 360 Grad, bietet unsichtbare Kabelverlegung und auf Wunsch zusätzliche Ablagen für Decoder und Soundbar als Zubehör.

Nuestro deseo era diseñar un soporte que se integrara de la mejor forma con el diseño esencial de los últimos modelos de televisores. Apollo, que consta de pocos elementos que ponen de relieve su pureza geométrica, permite la rotación de 360°, ocultar los cables y la posibilidad de añadir accesorios porta codificador y barra de sonido.

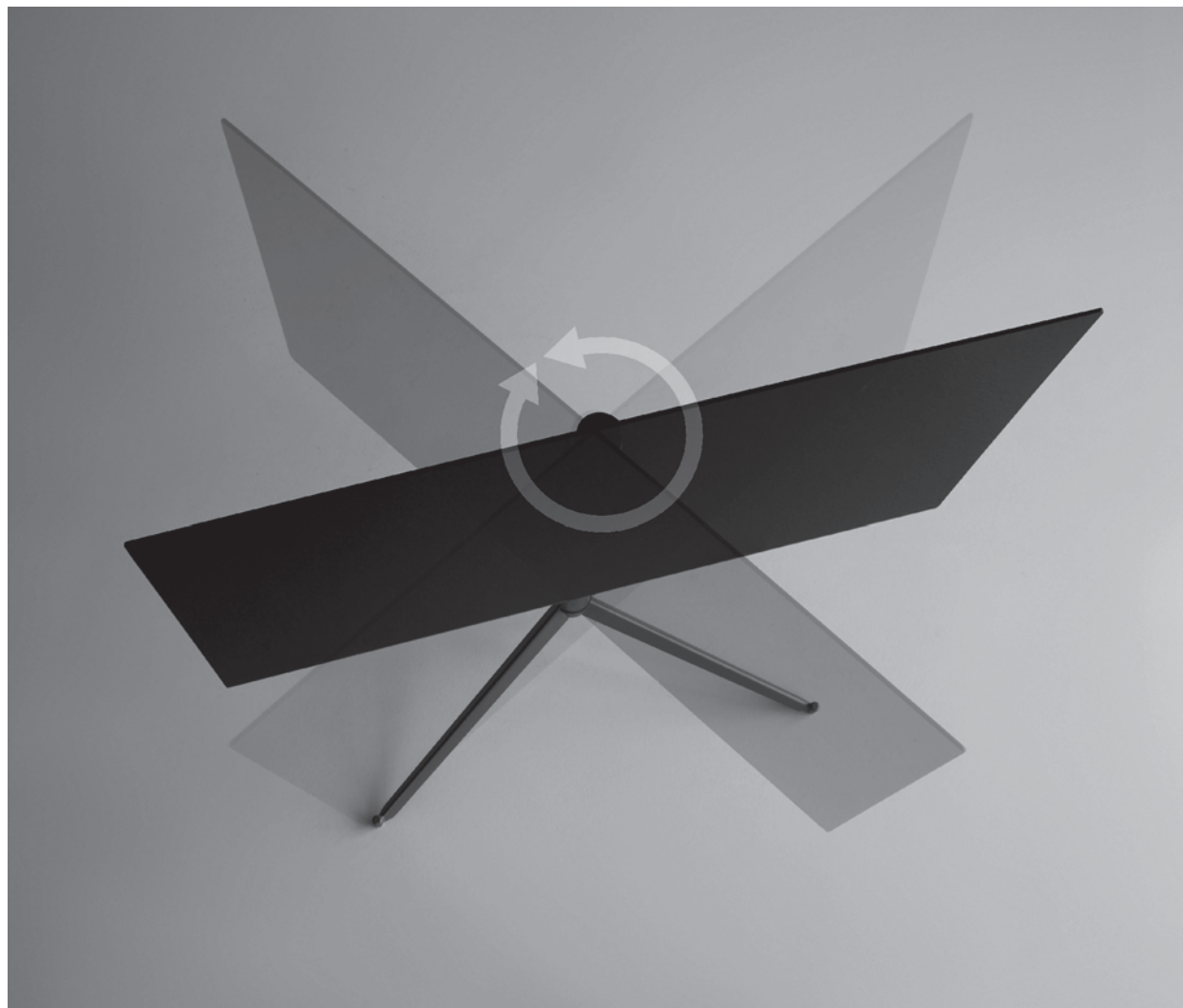

i cavi della TV e di eventuali unità multimediali sono completamente nascosti.

the TV and multimedia unit wires are completely hidden.

les fils de la TV et des unités multimédias sont complètement dissimulés.

Die Kabel des Fernsehers und der Multimedia sind vollkommen unsichtbar.

los cables de la TV y de los sistemas multimedia quedan completamente ocultos.



supporto monitor universale per TV da 40 a 65 pollici.

universal monitor support for TV from 40 to 65 inches.

support moniteur universel pour TV de 40 à 65 pouces.

Universal-Monitor-Halter für TV von 40 bis 65 Zoll.

soporte de monitor universal para TV de 40 a 65 pulgadas.



Rotazione 360°

Rotation 360°

Rotation 360°

Rotation 360°

Rotación 360°

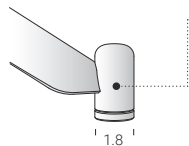

C acciaio verniciato/painted steel/acier peint
lackierter Stahl/acero pintado

- C12** bianco/white
- C21** seta/silk
- C30** ghisa/cast-iron
- C08** nero/black
- C29** bronzo/bronze

PORTA TV / TV SUPPORT / PORTE TV / FERNSEHSTAND / SOPORTE TV

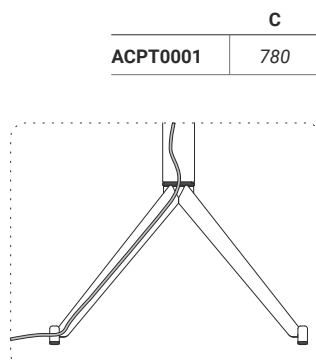
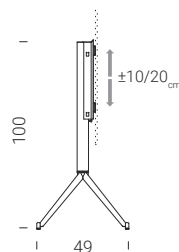
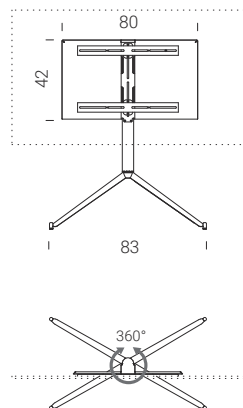

C	
ACPT0001	780

**PORTA DVD-PLAYER / DVD-PLAYER SHELF / ÉTAGÈRE PORTE-LECTEUR DVD
BODEN FÜR DVD-PLAYER / ESTANTE PORTA DVD**

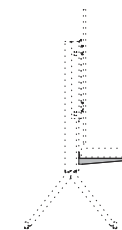
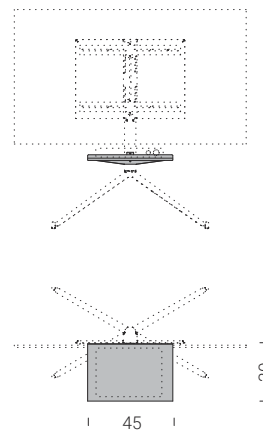

C	
AACC0018	105

RUOTE / CASTORS / ROUES / RÄDERN / RUEDAS

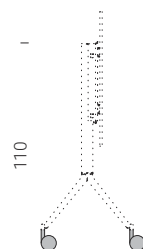
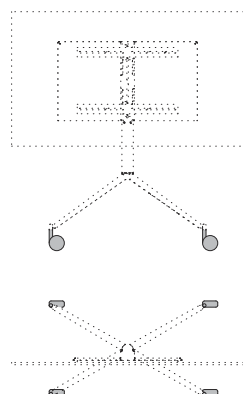

C12 C08	
AACC0019	99

**PORTA SOUNDBAR / SOUNDBAR SUPPORT / SUPPORT BARRE DE SON
SOUNDBAR-HALTER / SOPORTE BARRA DE SONIDO**

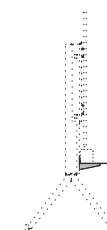
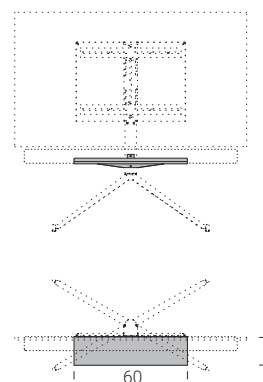

C	
AACC0024	128

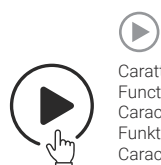

Caratteristiche funzionali
Functional characteristics
Caractéristiques fonctionnelles
Funktionale merkmale
Características funcionales

SPIN 360

tv dimension: 40" - 65"

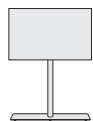

SPIN 360 È UN SUPPORTO TV DISEGNATO E PROGETTATO PER UNA PERFETTA INTEGRAZIONE CON I MONITOR DAL DESIGN PIÙ SOFISTICATO. NASCONDERE I CAVI COMPLETAMENTE AL SUO INTERNO E ORIENTARE LA COLONNA A 360 GRADI, GARANTISCE MASSIMA FUNZIONALITÀ E PUREZZA DI DISEGNO. SPIN 360 È DISPONIBILE NELLA VERSIONE CON BASE IN ACCIAIO SPESSORE 6MM, CON CONTENITORE PER UNITÀ MULTIMEDIALI APERTO O CHIUSO, IN DUE ALTEZZE DISTINTE H=100 / 120 CM.

Spin 360 is a TV support designed and manufactured for perfect integration with the most sophisticated monitor designs. It completely hides wires within and the column can be turned 360 degrees, guaranteeing maximum functionality and clean design. Spin 360 is available in a version with a 6mm thick steel base, with a container for multimedia units opened or closed, in two distinct heights H=100 / 120 cm.

Spin 360 est un support pour TV dessiné et conçu pour une intégration parfaite avec les écrans aux designs les plus sophistiqués. Pour un maximum de fonctionnalité et de pureté du dessin dissimuler les fils complètement à l'intérieur et orienter la colonne à 360°. Spin 360 est disponible dans la version avec base en acier, épaisseur 6 mm, avec module de rangement pour unités multimédias ouvert ou fermé, disponible dans deux hauteurs distinctes H=100/120 cm.

Spin 360 ist ein TV-Halter, der für eine perfekte Integration von hoch entwickelten Bildschirmen entworfen wurde. Die vollständige Unterbringung der Kabel im Halter und die Drehmöglichkeit der Säule um 360 Grad, bieten höchste Zweckmäßigkeit und ein klares Design. Spin 360 ist in der Version mit einem Fuß aus 6 mm starkem Stahl, einer multimedialen, offenen oder geschlossenen Einheit, in zwei unterschiedlichen Höhen von 100 oder 120 cm erhältlich.

Spin 360 es un soporte de TV diseñado y desarrollado para una integración perfecta con la pantalla de diseño más sofisticado. Ocultar los cables completamente en su interior y orientar la columna a 360 grados, garantiza la máxima durabilidad y la pureza del diseño. Spin 360 está disponible en versión con base de acero de 6 mm de grosor, con compartimento para sistemas multimedia abierto o cerrado, en dos alturas diferentes H = 100/120 cm.



i cavi della TV e di eventuali unità multimediali sono completamente nascosti.
the TV and multimedia unit wires are completely hidden.

les fils de la TV et des unités multimédias sont complètement dissimulés.

Die Kabel des Fernsehers und der Multimedia sind vollkommen unsichtbar.

los cables de la TV y de los sistemas multimedia quedan completamente ocultos.



supporto monitor universale per TV da 40 a 65 pollici.

universal monitor support for TV from 40 to 65 inches.

support moniteur universel pour TV de 40 à 65 pouces.

Universal-Monitor-Halter für TV von 40 bis 65 Zoll.

soporte de monitor universal para TV de 40 a 65 pulgadas.



Rotazione 360°
Rotation 360°
Rotation 360°
Rotación 360°

- C** acciaio verniciato/painted steel/acier peint
lackierter Stahl/acero pintado
- C12** bianco/white
C21 seta/silk
C30 ghisa/cast-iron
C08 nero/black
C29 bronzo/bronze

PORTA TV / TV SUPPORT / PORTE TV / FERNSEHSTAND / SOPORTE TV

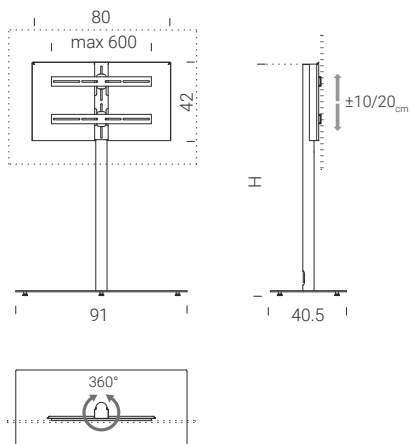

	H	C
NCPT0001	100	860
NCPT0002	120	880

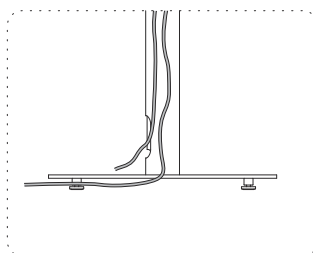

**PORTA TV + ANTA RIBALTA / TV SUPPORT + FLAP DOOR / PORTE TV + PORTE À ABATTANT
FERNSEHSTAND + KLAPPTÜR / SOPORTE TV + PUERTA ABATIBLE**

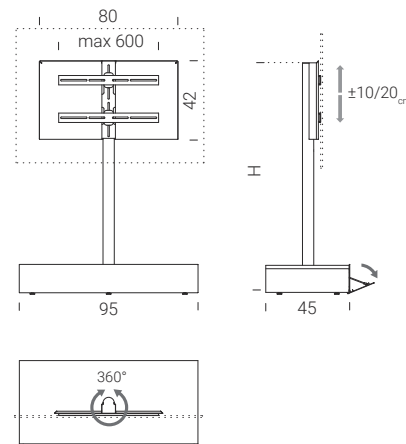

	H	C
NCPT0005	100	1540
NCPT0006	120	1560

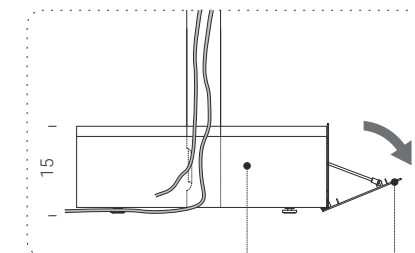

legno/wood/bois
Holz/madera

acciaio/steel/acier
Stahl/acero

**PORTA TV + CONTENITORE APERTO / TV SUPPORT + OPEN CABINET
PORTE TV + COMPARTIMENT OUVERT / FERNSEHSTAND + OFFENER BEHÄLTER
SOPORTE TV + MODULO ABIERTO**

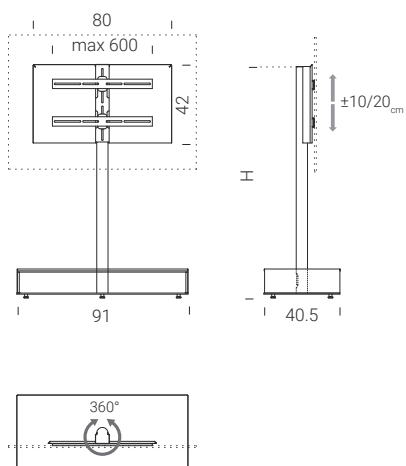

	H	C
NCPT0003	100	1155
NCPT0004	120	1175

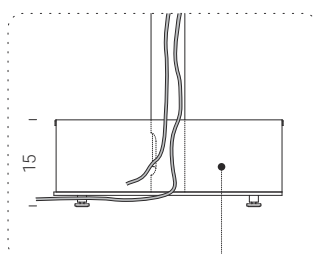

acciaio/steel/acier
Stahl/acero

**PORTA SOUNDBAR / SOUNDBAR SUPPORT / SUPPORT BARRE DE SON
SOUNDBAR-HALTER / SOPORTE BARRA DE SONIDO**

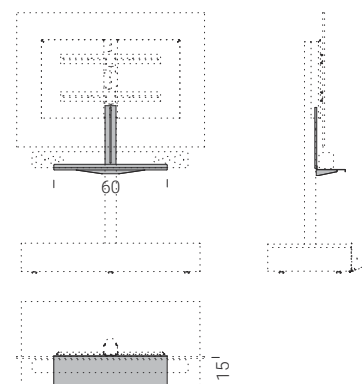

	C
NACC0005	145



i cavi della TV e di eventuali unità multimediali sono completamente nascosti
the TV and multimedia unit wires are completely hidden
les fils de la TV et des unités multimédias sont complètement dissimulés
die Kabel des Fernsehers und der Multimedia sind vollkommen unsichtbar
los cables de la TV y de los sistemas multimedia quedan completamente ocultos



supporto monitor universale per TV da 40 a 65 pollici.
universal monitor support for TV from 40 to 65 inches.
support moniteur universel pour TV de 40 à 65 pouces.
Universal-Monitor-Halter für TV von 40 bis 65 Zoll.
soporte de monitor universal para TV de 40 a 65 pulgadas.



disponibili riduzioni a misura
tailor-made reduction available
disponibles réductions sur mesure
Verkleinerung nach Kundenwunsch
disponibles reducciones a medida

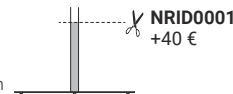

Caratteristiche funzionali
Functional characteristics
Caractéristiques fonctionnelles
Funktionale merkmale
Características funcionales

SYSTEM MULTIMEDIA

tv dimension: 40" - 65"

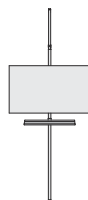

L'ASTA TELESCOPIA EXTENDO E IL PROFILO A PARETE EXTENDO SONO PRODOTTI ACCESSORIABILI CON STAFFA SUPPORTO MONITOR UNIVERSALE, RIPIANI PER UNITÀ MULTIMEDIALI, RIPIANI PER LIBRI, RIVISTE, DVD, CD. LE CLIP FERMA-CAVI IN DOTAZIONE CON LA STAFFA MONITOR CONSENTO DI EFFETTUARE IL CABLAGGIO ALL'ESTERNO DEL PROFILO.

The Extendo telescopic pole and Extendo wall profile are products easily accessorised with a universal monitor support bracket, shelving for multimedia units or shelving for books, magazines, DVDs and CDs. The cable-tie clips supplied with the monitor bracket enable wiring outside the profile.

La tige télescopique extendo et le profilé mural extendo sont des produits pouvant être équipés de fixation de support de moniteur universel, d'étagères pour unités multimédia, d'étagères pour livres, revues, DVD, CD. Le clip serre-câble fourni avec la fixation de support de moniteur permet d'effectuer le câblage à l'extérieur du profilé.

Die extendo Teleskopstange und das extendo Wandprofil, können mit Universal-Monitor-Halter, Fächer für multimediale Geräte, Fächer für Bücher, Zeitschriften, DVD und CD ausgestattet werden. Die zusammen mit dem Monitorhalter gelieferte Kabelklemmen ermöglichen die Verkabelung an der Außenseite des Profils.

La barra telescópica extendo y el perfil de sujeción a pared extendo son productos equipables con accesorios como el soporte de monitor universal o los estantes para libros, revistas, DVD o CD. El clip sujetacables que viene con el soporte de monitor permite efectuar el cableado por fuera del perfil.



supporto monitor universale per TV da 40 a 65 pollici.
universal monitor support for TV from 40 to 65 inches.
support moniteur universel pour TV de 40 à 65 pouces.
Universal-Monitor-Halter für TV von 40 bis 65 Zoll.
soporte de monitor universal para TV de 40 a 65 pulgadas.



Rotazione 160°
Rotation 160°
Rotation 160°
Rotation 160°
Rotación 160°



**PROFILO ESTENSIBILE EXTENDO / EXTENDO EXTENDABLE PROFILE / PROFILÉ EXTENSIBLE EXTENDO
AUSZIEHBARE PROFILE EXTENDO / BORDE EXTENSIBLE SEXTENDO**

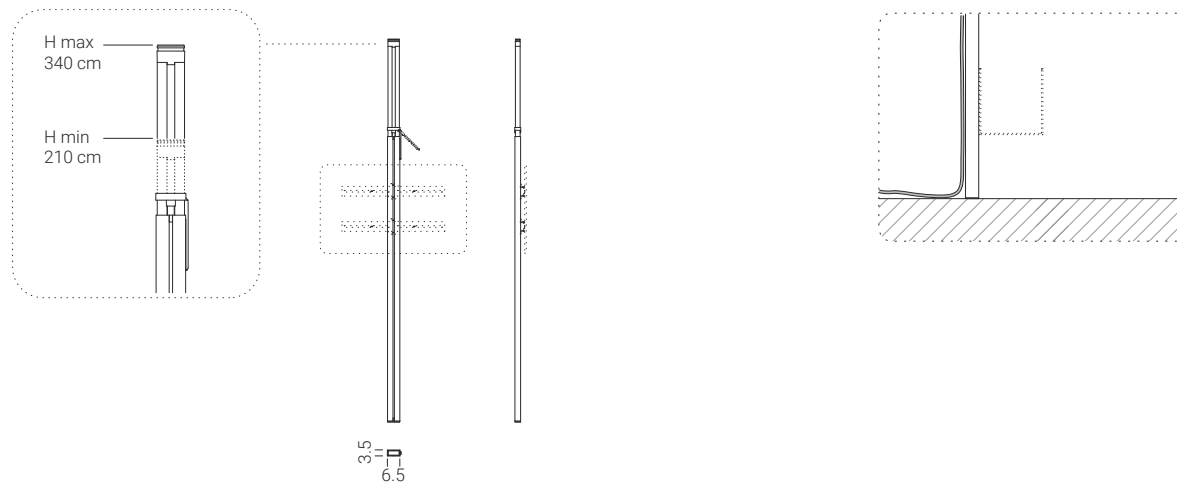

	A x B	C
EXTE0001	6.5 x 3.5	280

**PROFILO EXTENDO A PARETE / EXTENDO WALL-MOUNT PROFILE / PROFILÉ EXTENDO MURAL
WANDPROFIL EXTENDO / BORDE EXTENDO DE PARED**

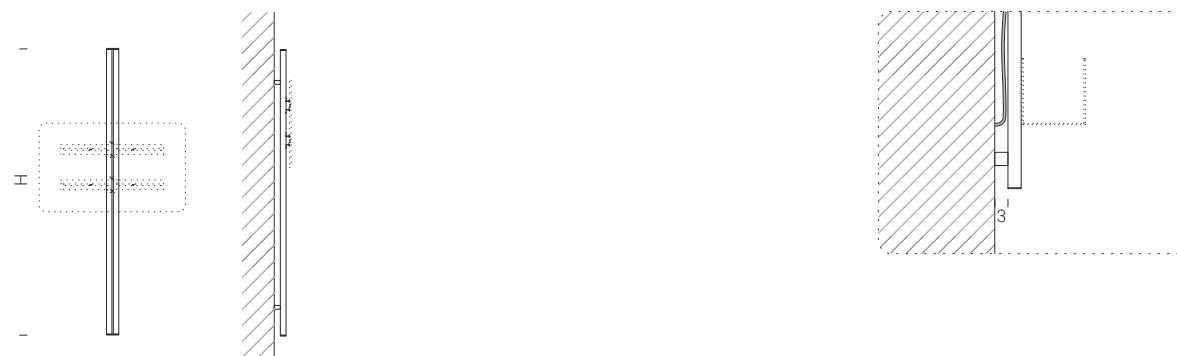

	A x B	H	C
EXTE0007	6.5 x 3.5	80	139
EXTE0002	6.5 x 3.5	130	160
EXTE0003	6.5 x 3.5	190	180

disponibili riduzioni a misura
tailor-made reduction available
disponibles réductions sur mesure
Verkleinerung nach Kundenwunsch
disponibles reducciones a medida

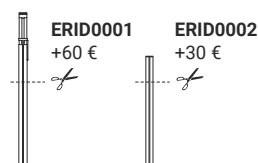

Sconsigliamo l'utilizzo degli adattatori in composizioni con asta telescopica extendo singola.
We advise you against using adaptors in compositions with a single extendo telescopic bar.
Nous déconseillons l'utilisation d'adaptateurs dans des compositions avec une seule barre télescopique extendo.
Wir nicht empfehlen, die Adapter in Zusammensetzungen mit einem einzigen Teleskopstange extendo verwenden.
No se recomienda utilizar los adaptadores en composiciones con una sola barra telescópica extendo.

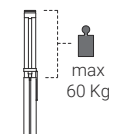

Il carico massimo sul profilo superiore è 60 kg
The maximum load on the upper profile is 60 kg
La charge maximale sur le profilé supérieur est de 60 kg
Das obere Profil kann maximal mit 60 kg belastet werden
La carga maxima en el perfil superior es de 60 kg

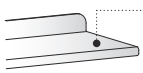

C acciaio verniciato/painted steel/acier peint
lackierter Stahl/acero pintado

- C12** bianco/white
- C21** seta/silk
- C30** ghisa/cast-iron
- C08** nero/black
- C29** bronzo/bronze

**PROFILO RACCOGLI CAVI / PROFILE COLLECTS CABLES / PROFIL COLLECTE LES CÂBLES
PROFIL SAMMELT KABEL / PERFIL RECOGE CABLES**

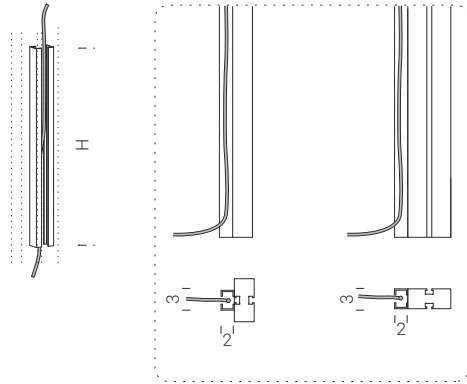

	A x B	H	C
AACC0020	3 x 2	80	40
AACC0021	3 x 2	130	48
AACC0022	3 x 2	190	64

Utilizzabile con/Usable with/Utilisable avec
Verwendbar mit/Utilizable con

**AACC0008 AACC0009 EXTE0001
EXTE0007 EXTE0002 EXTE0003**

**RIPIANO IN ALLUMINIO AD U / ALUMINIUM U SHELF / ÉTAGÈRE EN ALUMINIUM U
BODEN AUS ALUMINIUM U / ESTANTE DE ALUMINIO U**

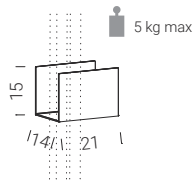

	C
ARIP0001	48

**RIPIANO IN ALLUMINIO A C / ALUMINIUM C SHELF / ÉTAGÈRE EN ALUMINIUM C
BODEN AUS ALUMINIUM C / ESTANTE DE ALUMINIO C**

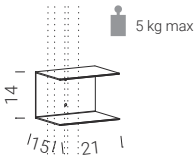

	C
ARIP0002	48

**COPPIA STAFFE SUPPORTO MONITOR ROTANTI / PAIR OF ROTATING MONITOR SUPPORT RODS
DEUX ÉTRIERS DE SUPPORT ÉCRAN ROTATIFS / PAAR DREHHALTERUNGEN MONITORTRÄGER
PAR DE FIJACIONES GIRATORIAS PARA SOPORTE MONITOR**

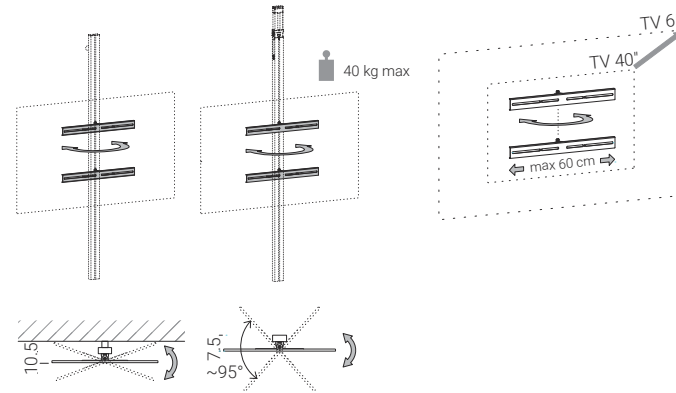

	C
AACC0003	175



**ADATTATORE PER FISSAGGIO LATERALE / ADAPTER FOR SIDE FIXATION
ADAPTER FÜR SEITENBEFESTIGUNG / ADAPTER POUR MONTAGE LATÉRAL
ADAPTADOR PARA MONTAJE LATERAL**

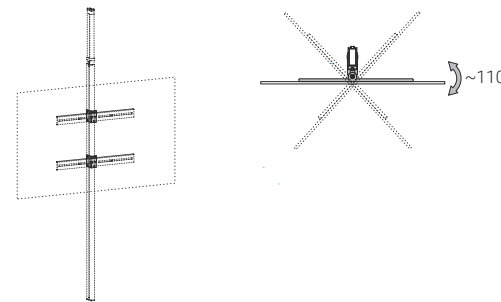

	C
AADA0001	47

Utilizzabile con/Usable with
Utilisable avec/Verwendbar mit
Utilizable con

**AACC0003
AACC0004
AACC0023**



supporto monitor universale per TV da 40 a 65 pollici.
universal monitor support for TV from 40 to 65 inches.
support moniteur universel pour TV de 40 à 65 pouces.
Universal-Monitor-Halter für TV von 40 bis 65 Zoll.
soporte de monitor universal para TV de 40 a 65 pulgadas.



Distanza max dei fori orizzontali di fissaggio sul retro del televisore (60 cm).
Max distance of the horizontal fixing holes on the back of the TV (60 cm).
Distance maximale des trous de fixation horizontaux sur l'arrière du téléviseur (60 cm).
Max Abstand der horizontalen Befestigungslöcher auf der Rückseite des TV (60 cm).
Distancia máxima de los agujeros de fijación horizontal en la parte posterior de la TV (60 cm).



include 5 clip ferma cavo
includes 5 cable clips
comprend 5 clips de cable
enthält 5 Kabelclip-Clips
incluye 5 clips de cable



Caratteristiche funzionali
Functional characteristics
Caractéristiques fonctionnelles
Funktionale merkmale
Características funcionales



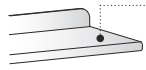

C acciaio verniciato/painted steel/acier peint
lackierter Stahl/acero pintado

- C12** bianco/white
- C21** seta/silk
- C30** ghisa/cast-iron
- C08** nero/black
- C29** bronzo/bronze

**RIPIANO PORTA DVD-PLAYER / DVD-PLAYER SHELF / ÉTAGÈRE PORTE-LECTEUR DVD
BODEN FÜR DVD-PLAYER / ESTANTE PORTA DVD-PLAYER**

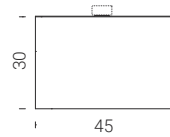
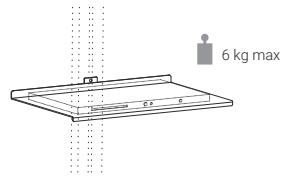

C	
AACC0004	103

**PORTA SOUNDBAR / SOUNDBAR SUPPORT / SUPPORT BARRE DE SON
SOUNDBAR-HALTER / SOPORTE BARRA DE SONIDO**

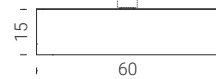
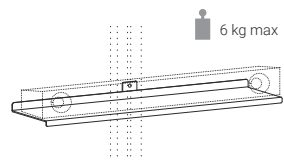

C	
AACC0023	131

**TAVOLINO SOSPESO / SUSPENDED TABLE / TABLETTE SUSPENDUE
FREIHÄNGENDER TISH / MESITA COLGANTE**

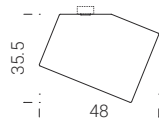
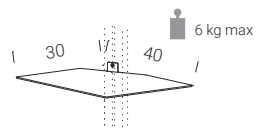

C	
(L) ARIP0012	103

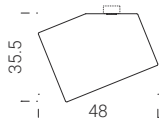
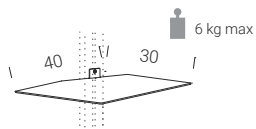

C	
(R) ARIP0013	103

**FERMALIBRO-CD / BOOK-CD HOLDER / DIVISEUR LIVRES-CD
BUCH-/CD-STÜTZE / APOYALIBROS-CDS**

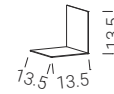

C	
AACC0001	17

PORTA CD / CD HOLDER / PORTE-CD / CD-HALTER / PORTACDS

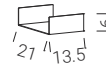

C	
AACC0002	18

TITANO

tv dimension: 55" - 85"

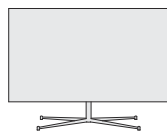

TITANO PERMETTE L'INSTALLAZIONE DI MONITOR DAI 55" AGLI 85". I CAVI SONO COMPLETAMENTE OCCULTATI ALL'INTERNO DELLA COLONNA LIBERAMENTE ORIENTABILE A 360°. UNA COPPIA DI CARTER POSTERIORI NASCONDE E DÀ ACCESSO RAPIDO ALLE PRESE DELLA TV. È ACCESSORIABILE CON UN SUPPORTO PER SOUND-BAR O LETTORI MULTIMEDIALI CHE INTEGRA E CELA COMPLETAMENTE I CAVI.

Titano allows the installation of monitors of a size from 55" to 85". The cables are completely hidden by the freely and fully orientable stand. A pair of back covers hides and allows rapid access to the TV electrical outlets. It can be accessorized with a sound-bar or multimedia readers support that completely incorporates and conceals the cables.

Titano permet l'installation de télévisions allant de 55 à 85 pouces. Les câbles sont complètement dissimulés à l'intérieur de la colonne, laquelle peut pivoter librement sur 360°. Deux panneaux de protection arrière permettent de dissimuler et d'accéder rapidement aux prises TV. Des accessoires tels qu'un support pour barres de son ou lecteurs multimédias peuvent être ajoutés, avec incorporation et dissimulation complètes des câbles.

Titano ermöglicht die Montage von Bildschirmen von 55" bis zu 85". Die Kabel sind komplett in der um 360° frei drehbaren Säule versteckt. Zwei Gehäuse auf der Rückseite verstecken und ermöglichen den leichten Zugriff zu den TV-Steckdosen. Er kann mit einer Unterlage für Sound-Bar oder multimedialen Playern ausgestattet werden, die die Kabel integriert und komplett versteckt.

Los cables están completamente ocultos dentro de la columna ajustable de 360°. Un par de tapas traseras ocultan y dan acceso rápido a las tomas de televisión. Puede equiparse con un soporte para barras de sonido o reproductores multimedia que integra y oculta completamente los cables.

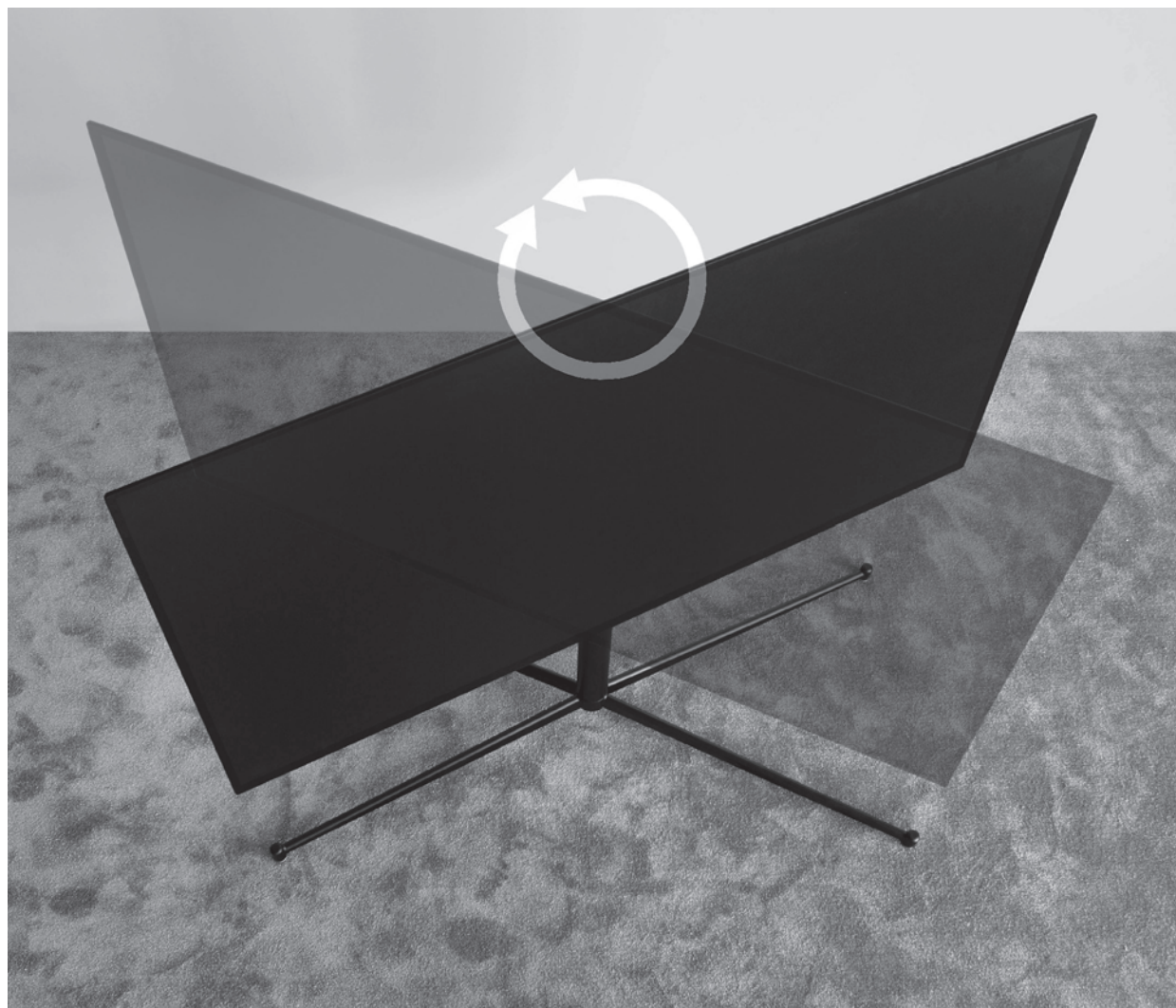

i cavi della TV e di eventuali unità multimediali sono completamente nascosti.

the TV and multimedia unit wires are completely hidden.

les fils de la TV et des unités multimédias sont complètement dissimulés.

Die Kabel des Fernsehers und der Multimedia sind vollkommen unsichtbar.

los cables de la TV y de los sistemas multimedia quedan completamente ocultos.



supporto monitor universale per TV da 55 a 85 pollici.

universal monitor support for TV from 55 to 85 inches.

support moniteur universel pour TV de 55 à 85 pouces.

Universal-Monitor-Halter für TV von 55 bis 85 Zoll.

soporte de monitor universal para TV de 55 a 85 pulgadas.



Rotazione 360°
Rotation 360°
Rotation 360°
Rotación 360°

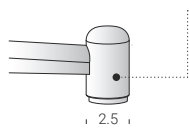

- C** acciaio verniciato/painted steel/acier peint
lackierter Stahl/acero pintado
- C12** bianco/white
C21 seta/silk
C30 ghisa/cast-iron
C08 nero/black
C29 bronzo/bronze

PORTA TV / TV STAND / SUPPORT TV / TV-HALTERUNG / SOPORTE PARA TV

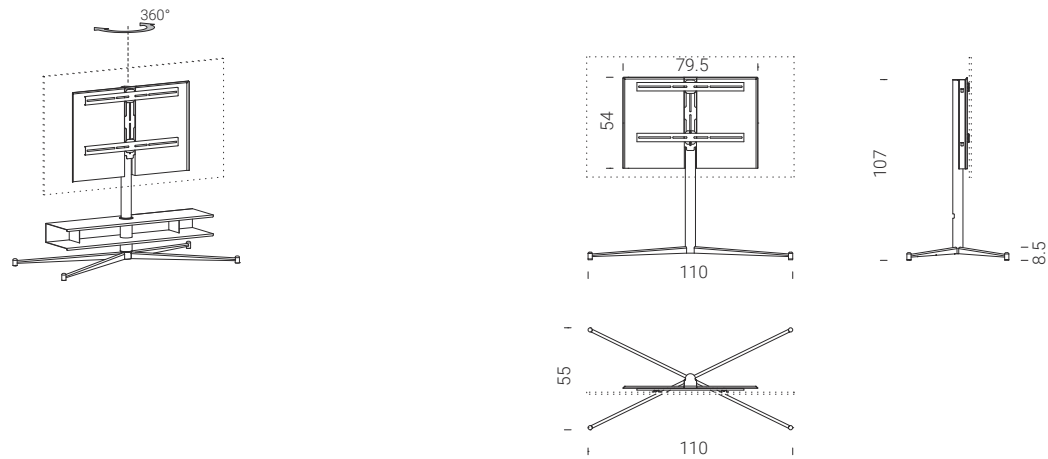

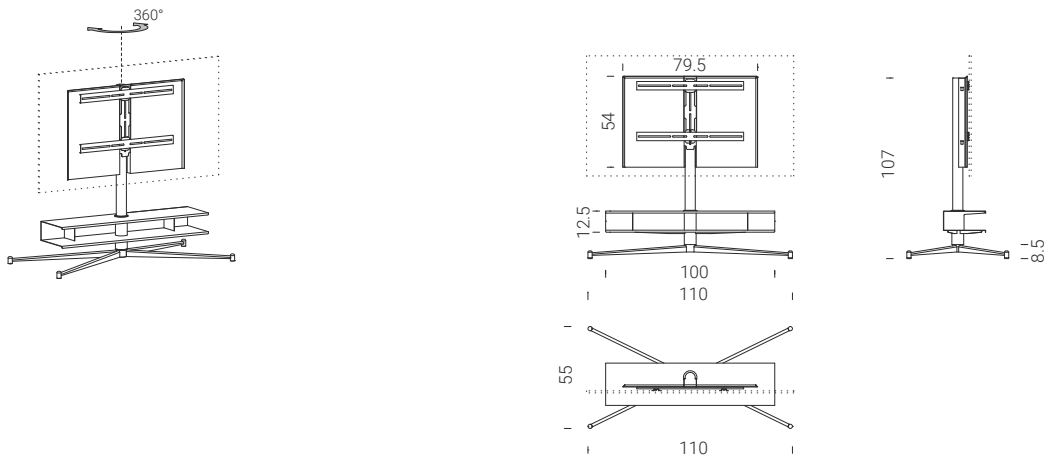

C	
ECPT0401	880

**PORTA TV CON RIPIANO / TV STAND WITH SHELF / SUPPORT TV AVEC ÉTAGÈRE
TV-HALTERUNG MIT EINLEGEBODEN / SOPORTE PARA TV CON ESTANTE**



C	
ECPT0402	1150

-  Caratteristiche funzionali
Functional characteristics
Caractéristiques fonctionnelles
Funktionale merkmale
Características funcionales
- 

URANO

tv dimension: 55" - 85"

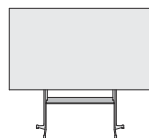

PENSATO PER L'INSTALLAZIONE DI MONITOR DI GRANDE FORMATO DAI 55" AGLI 85", IL CARTER POSTERIORE HA UN SISTEMA DI SGANCIAMENTO RAPIDO CHE PERMETTE DI NASCONDERE E ACCEDERE ALLE PRESE TV. IL PANNELLO TV NON RUOTA RISPETTO AL SUPPORTO, MA L'INSIEME PUÒ ESSERE FACILMENTE SPOSTATO GRAZIE AI SUPPORTI IN TEFLON. UN RIPIANO ACCESSORIO PUÒ ESSERE UTILIZZATO COME SUPPORTO DI SOUND-BAR O LETTORI MULTIMEDIALI.

Designed for the installation of large monitors (from 55" to 85"), the back cover has a rapid fit system that hides and allows access to the TV plugs. The TV panel does not rotate around the support but the whole unit can be moved easily thanks to the Teflon supports. An accessory shelf can be used for sound-bars or multimedia readers.

Conçu pour l'installation de télévisions grand format de 55 à 85 pouces, le panneau arrière dispose d'un système de décrochage rapide qui permet de dissimuler et d'accéder aux prises TV. Le panneau TV ne tourne pas par rapport au support, mais l'ensemble peut être facilement déplacé grâce aux supports en téflon. Une étagère pour accessoires peut être utilisée comme support pour les barres de son ou les lecteurs multimédias

Gedacht für die Montage von großen Bildschirmen (von 55" bis 85"), hat das Gehäuse auf der Rückseite ein Schnellabhängsystem, wodurch die TV-Steckdosen versteckt werden und sie leicht erreicht werden können. Die TV-Platte dreht sich nicht unabhängig von der Unterlage, aber das Ganze kann dank der Teflon-Unterlagen leicht verstellt werden. Eine zusätzliche Ablage kann als Unterlage für Sound-Bar oder multimediale Player dienen.

Diseñada para la instalación de monitores de gran formato de 55" a 85", la cubierta trasera tiene un sistema de liberación rápida que permite ocultar y acceder a las tomas de TV. El panel del televisor no gira con respecto al soporte, pero el conjunto puede moverse fácilmente gracias a los soportes de teflón. Un estante accesorio puede utilizarse como soporte para barras de sonido o reproductores multimedia.



supporto monitor universale per TV da 55 a 85 pollici.
universal monitor support for TV from 55 to 85 inches.
support moniteur universel pour TV de 55 à 85 pouces.
Universal-Monitor-Halter für TV von 55 bis 85 Zoll.
soporte de monitor universal para TV de 55 a 85 pulgadas.

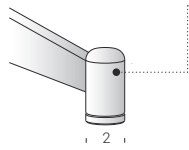

- C** acciaio verniciato/painted steel/acier peint
lackierter Stahl/acero pintado
- C12** bianco/white
C21 seta/silk
C30 ghisa/cast-iron
C08 nero/black
C29 bronzo/bronze

PORTA TV / TV STAND / SUPPORT TV / TV-HALTERUNG / SOPORTE PARA TV

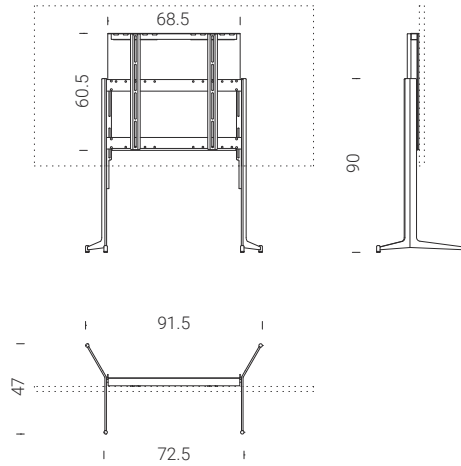
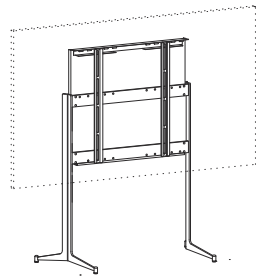

C	
ECPT0501	840

PORTA TV CON RIPIANO / TV STAND WITH SHELF / SUPPORT TV AVEC ÉTAGÈRE
TV-HALTERUNG MIT EINLEGEBODEN / SOPORTE PARA TV CON ESTANTE

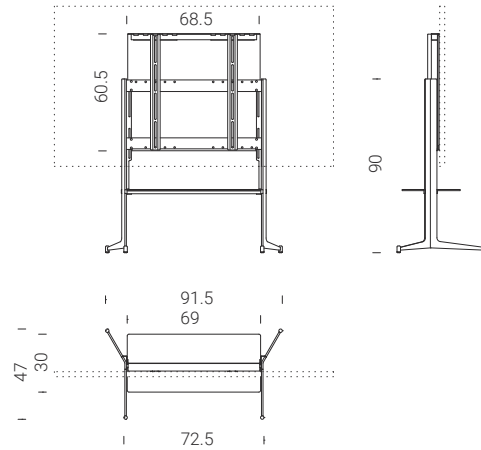
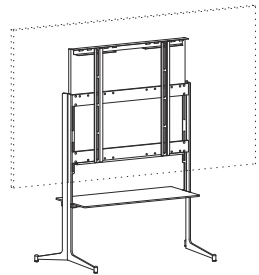

C	
ECPT0502	1080

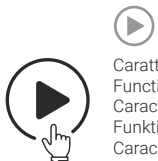

Caratteristiche funzionali
Functional characteristics
Caractéristiques fonctionnelles
Funktionale merkmale
Características funcionales

SLIDE

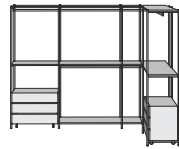

LE COPPIE DI PROFILI VERTICALI, I RIPIANI E LE BARRE APPENDERIA SONO ORDINABILI AL CENTIMETRO, CIÒ CONSENTE DI PROGETTARE LO SPAZIO DESIDERATO IN MODO SARTORIALE SENZA EXTRACOSTI DI RIDUZIONI.

The pairs of upright profiles, the shelves and hanging rails can be sized to the centimetre, making it possible to design a tailor-made space without the added cost of reductions.

Les paires de profils verticaux, les étagères et les barres porte-vêtements peuvent être commandées au centimètre, ceci permet d'organiser l'espace souhaité « sur mesure » sans coûts supplémentaires de réduction.

Die Paare vertikaler Profile, die Böden und die Aufhängestangen können zentimetergenau bestellt werden. Dadurch kann der gewünschte Raum ohne zusätzliche Kosten für Kürzungen maßgeschneidert geplant werden.

Los pares de perfiles verticales, estantes y barras de colgar se pueden pedir por centímetros, lo que permite diseñar el espacio deseado adaptándolos sin costos adicionales de reducción.





PRODUCT CONCEPT

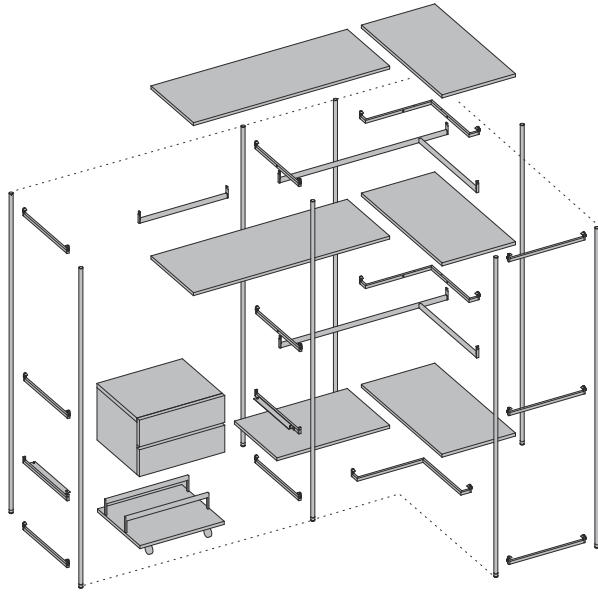

L modules
61.5 – 91.5 – 121.5

H modules
riducibile al centimetro
reducible to the centimetre
réductible au centimètre
verkürzbar auf den Zentimeter
reducible al centimetro

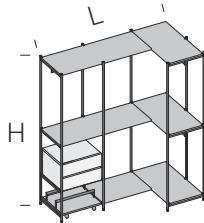

Ripiani e contenitori hanno libera posizione in altezza, (al centimetro).

Shelves and containers can be positioned at any height (to the centimetre).

Les étagères et les conteneurs peuvent être positionnés librement en hauteur (au centimètre près).

Einlegeböden und Behälter sind in der Höhe frei einsetzbar (auf den Zentimeter).

Los estantes y contenedores tienen una altura libre (al centimetro).

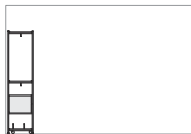

Pavimento / parete
Floor / wall
Sol / mur
Boden / Wand
Suelo / pared

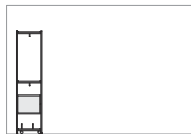

Pavimento / bifacciale
Floor / Double-sided
Sol / Double face
Boden / Zweiseitig
Suelo / Doble cara

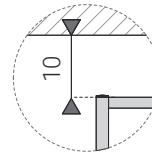

distanza minima dal soffitto (10 cm)
minimum distance from ceiling (10 cm)
distance minimale du plafond (10 cm)
Mindestabstand von Decke (10 cm)
distancia mínima del techo (10 cm)

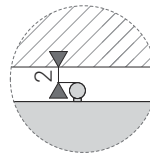
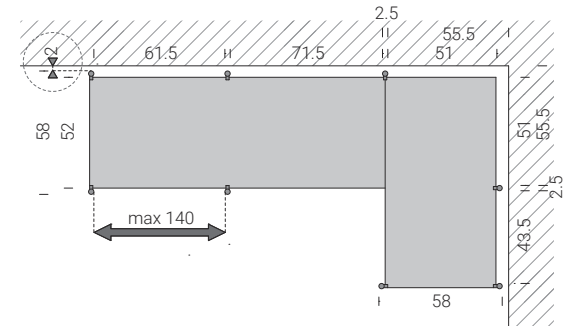
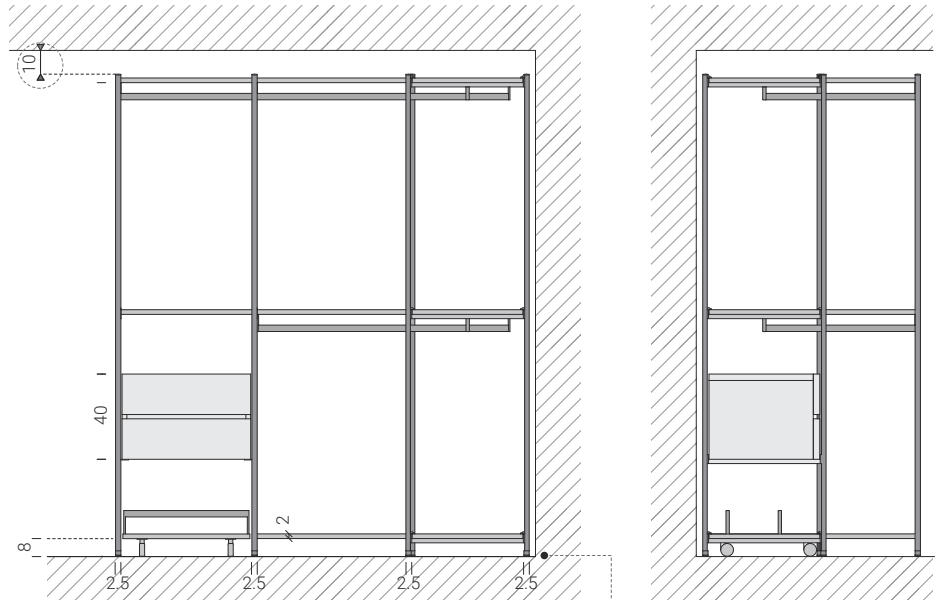

distanza minima dalle pareti 2 cm., i supporti a parete sono sempre inclusi
minimum distance from walls 2 cm., the wall supports are always included
distance minimale des murs 2 cm., les supports muraux sont toujours inclus
Mindestabstand von Wänden 2 cm., die Wandhalterungen sind immer im Lieferumfang inbegriffen
distancia mínima de las paredes 2 cm., los soportes de pared siempre van incluidos

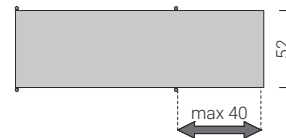

per i ripiani lo sbalzo massimo consentito è di 40 cm.
for shelves, the maximum permitted cantilever is 40 cm.
pour les étagères, le porte-à-faux maximum autorisé est de 40 cm.
Für die Einlegeböden ist ein maximaler Überstand von 40 cm zulässig.
para los estantes el voladizo máximo permitido es de 40 cm.



Riduzioni a misura disponibili su profili verticali, ripiani e barre appendiera.
Measurement reductions available on vertical profiles, shelves and hanging rails.
Réductions sur mesure possibles sur les profilés verticaux, les étagères et les barres de penderie.
Verkürzungen nach Kundenwunsch für vertikale Profile, Einlegeböden und Aufhängestangen verfügbar.
Reducciones de tamaño disponibles en perfiles verticales, estantes y barras de colgar.

C alluminio verniciato/painted aluminium/aluminium peint
lackierter Aluminium/aluminio pintado

C12 bianco/white
C21 seta/silk
C30 ghisa/cast-iron
C08 nero/black
C29 bronzo/bronze

2.5

200 kg max

Q laccato/ lacquered/laqué
lackiert/lacado

Q05 bianco/white
Q16 seta/silk
Q17 corda/ecru
Q20 ghisa/cast-iron
Q04 nero/black
Q21 bronzo/bronze

M melaminico/ melamine/méla miné
Melamin/melamina

M03 bianco/white
M02 rovere moka/moka oak

COPPIA DI PROFILI VERTICALI / PAIR OF UPRIGHT PROFILES
PAIRE DE PROFILS VERTICAUX / EIN PAAR VERTIKALE PROFILE
PAR PERFILES VERTICALES

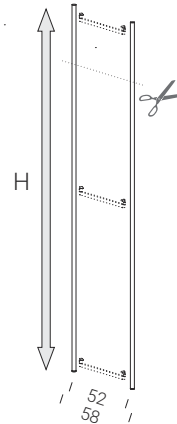
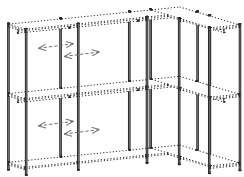

	H	C
LMON0001	180	145
LMON0001	210	157
LMON0001	240	168
LMON0001	260	175
LMON0001	350	198

100 cm => 30 Kg max
140 cm => 20 Kg max

SUPPORTO RIPIANO/SHELF SUPPORT/SUPPORT D'ÉTAGÈRE
BORDHALTER/SOPORTE PARA ESTANTE

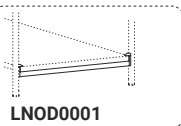
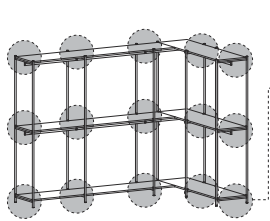

	C
LNOD0001	42

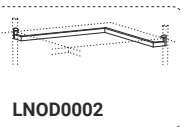
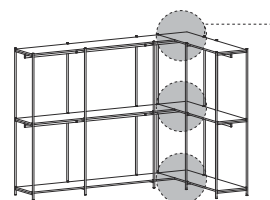

	C
LNOD0002	84

RIPIANO / SHELF / ÉTAGÈRE / BÖDEN / ESTANTE

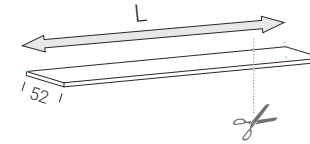
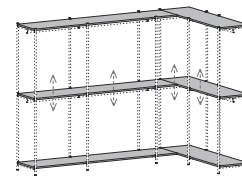

	L	M	Q
LRIP0001	66.5	80	106
LRIP0001	96.5	108	145
LRIP0001	130.5	147	199
LRIP0001	160.5	173	239
LRIP0001	194.5	212	293
LRIP0001	224.5	238	331
LRIP0001	254.5	265	371
LRIP0001	284.5	302	422

L < 100cm 35 Kg max
L > 100cm 25 Kg max

Per dimensioni maggiori di 284.5 cm è possibile unire 2 ripiani in corrispondenza di una spalla.
For dimensions greater than 284.5 cm, two shelves can be joined together in correspondence with a support profile.
Pour toute dimension supérieure à 284.5 cm il est possible de joindre 2 étagères au niveau d'un montant.
Für Abmessungen über 284.5 cm können zwei Böden auf Höhe eines Widerlagers vereint werden.
Para dimensiones mayores de 284.5 cm se pueden unir dos estantes combinados con una percha.

I ripiani posso essere uniti per ottenere composizioni ad angolo.
The shelves can be combined to obtain corner compositions.
Les étagères peuvent être unies pour obtenir des compositions d'angle.
Die Böden können für eine Eckzusammenstellung werden.
Los estantes se pueden unirlos para obtener composiciones de esquina.

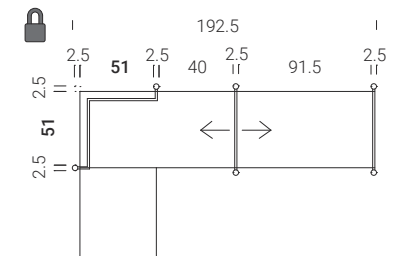
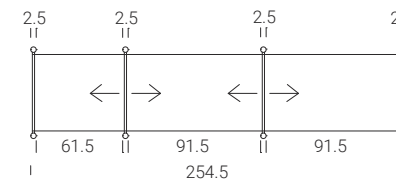

I supporti a parete sono sempre inclusi
The wall supports are always included
Les supports muraux sont toujours inclus
Die Wandhalterungen sind immer im Lieferumfang
Los soportes de pared siempre van incluidos

disponibili riduzioni a misura
custom reductions available
Verkürzungen auf Maß erhältlich
réductions sur mesure disponibles
disponibles reducciones a medida

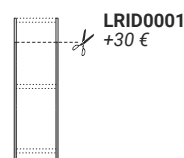

riduzione ripiano (prezzo per 1 taglio)
shelf reduction (price for 1 cut)
réduction étagère (prix pour 1 coupe)
Reduzierung (Preis für 1 Schnitt)
reducción de estante (precio por 1 corte)

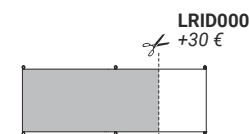

La spalla angolare ha posizione fissa
The corner support profile has a fixed position
Le montant d'angle a une position fixe
Das Winkelwiderlager ist fest positioniert
La percha angular es de posición fija

C acciaio verniciato/painted steel/acier peint
lackierter Stahl/acero pintado

C12 bianco/white
C21 seta/silk
C30 ghisa/cast-iron
C08 nero/black
C29 bronzo/bronze

Q laccato/ lacquered/laqué
lackiert/lacado

Q05 bianco/white
Q16 seta/silk
Q17 corda/ecru
Q20 ghisa/cast-iron
Q04 nero/black
Q21 bronzo/bronze

M melaminico/ melamine/mélaminé
Melamin/melamina

M03 bianco/white
M02 rovere moka/moka oak

TIRANTI / RODS / TIRANTES / STAHLSTANGEN / TIRANTES 

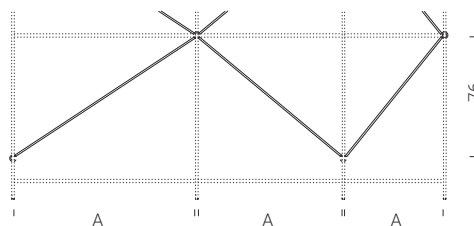
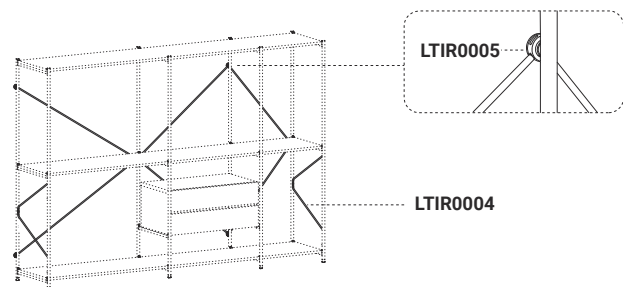

	C
* LTIR0005	68

	A x 76	C
LTIR0001	61.5 x 76	29
LTIR0002	91.5 x 76	36
LTIR0003	121.5 x 76	38

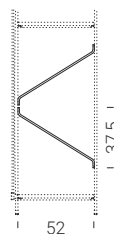

	A x 76	C
LTIR0004	52 x 37.5	34

RIPIANO PORTASCARPE / SHOE RACK SHELF / ÉTAGÈRE PORTE-CHAUSSURES
BODEN SCHUHABLAGE / ESTANTE PORTAZAPATOS

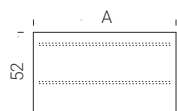

	A x 52 x 2	kg/ml	M	Q
LRIP0007	61.5 x 52 x 2	20	205	288
LRIP0008	91.5 x 52 x 2	20	234	354
LRIP0009	121.5 x 52 x 2	20	254	412

PORTAPANTALONI / TROUSER RAIL / PORTE-PANTALONS
HOSENHALTER / PORTAPANTALONES

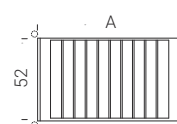

	A x 52 x 3	kg max	M	Q
LACC0011	61.5 x 52 x 3	10	405	454
LACC0012	91.5 x 52 x 3	10	449	500
LACC0013	121.5 x 52 x 3	10	504	566



I tiranti sono obbligatori per composizioni free standing.
The tie rods are required for free standing compositions.
Les tirants sont nécessaires pour les compositions autoportantes.
Die Zuganker sind für freistehende Zusammensetzungen notwendig.
Los tirantes son necesarios para composiciones independientes.



Il raccordo può accogliere 1,2 o 4 tiranti
the joint can house 1, 2 or 4 tie rods
Le raccord peut accueillir 1, 2 ou 4 tirants
Der Anschluss kann 1, 2 oder 4 Zuganker aufnehmen
El empalme puede acoplar 1,2 ó 4 tirantes



disponibili riduzioni a misura
custom reductions available
Verkürzungen auf Maß erhältlich
réductions sur mesure disponibles
disponibles reducciones a medida



CRID0007
+50 €

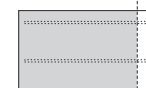

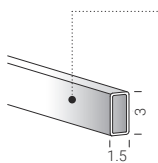

C alluminio verniciato/painted aluminium/aluminium peint
lackierter Aluminium/aluminio pintado

- C12** bianco/white
- C21** seta/silk
- C30** ghisa/cast-iron
- C08** nero/black
- C29** bronzo/bronze

BARRA A MISURA / RAIL TO MEASURE / BARRE SUR MESURE / STANGE NACH MAß / BARRA A MEDIDA

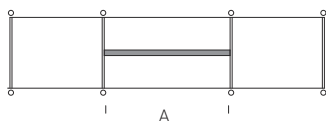

	A	kg max	C
LBAR0001	61.5	30	62
LBAR0001	91.5	30	68
LBAR0001	121.5	30	70
LBAR0001	140	30	78

**BARRA A SBALZO A MISURA / CANTILEVERED RAIL TO MEASURE / BARRE EN PORTE-À-FAUX
STANGE NACH MAß MIT ÜBERSTAND / BARRA EN VOLADIZO A MEDIDA**

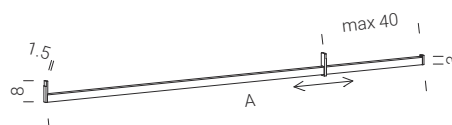
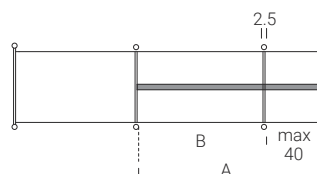

	A	B	kg max	C
LBAR0002	104	61.5	30	72
LBAR0002	134	91.5	30	78
LBAR0002	164	121.5	30	80
LBAR0002	182.5	140	30	88

BARRA ANGOLARE A MISURA / CORNER RAIL TO MEASURE / BARRE D'ANGLE SUR MESURE / WINKEL-STANGE NACH MAß / BARRA ANGULAR A MEDIDA

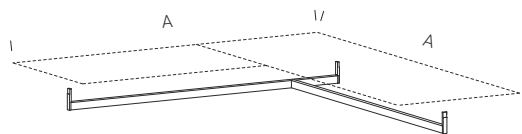
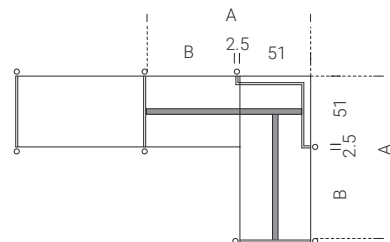

	A	B	kg max	C
LBAR0003	115	61.5	30	118
LBAR0003	145	91.5	30	128

**BARRA ANGOLARE A SBALZO A MISURA / CORNER CANTILEVERED RAIL TO MEASURE / BARRE D'ANGLE PORTE-À-FAUX SUR MESURE
WINKEL-STANGE NACH MAß MIT ÜBERSTAND / BARRA ANGULAR EN VOLADIZO A MEDIDA**

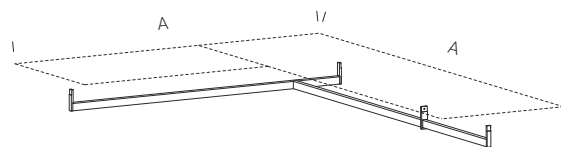
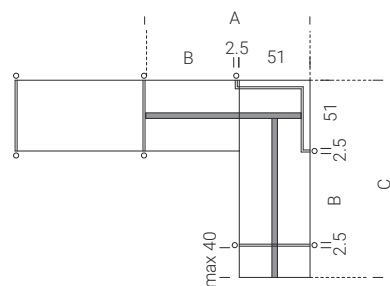

	A	B	C	kg max	C
LBAR0004	115	61.5	157.5	30	128
LBAR0004	145	91.5	188	30	138



disponibili riduzioni a misura
custom reductions available
Verkürzungen auf Maß erhältlich
réductions sur mesure disponibles
disponibles reducciones a medida

LRID0003
+20 €

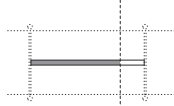

LRID0003
+20 €

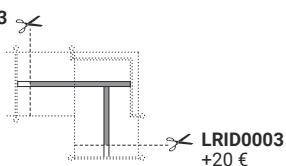

LRID0003
+20 €

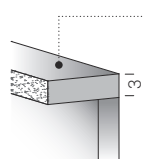

Q laccato/ lacquered/laqué
lackiert/lacado

- Q05** bianco/white
- Q16** seta/silk
- Q17** corda/ecru
- Q20** ghisa/cast-iron
- Q04** nero/black
- Q21** bronzo/bronze

M melaminico/ melamine/mélininé
Melamin/melamina

- M03** bianco/white
- M02** rovere moka/moka oak

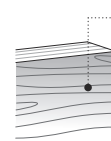

multistrato di betulla/multilayer birch
cintroplaqué de bouleau/birkensperholz
multistrato de abedul

Y06 betulla/birch

CONTENITORI / CABINETS / MODULES DE RANGEMENT / BEHÄLTER / CONTENEDORES

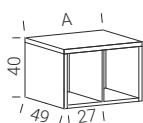
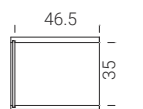

	A x B	kg max	M	Q
LCAS0001	61.5 x 40	20	388	562

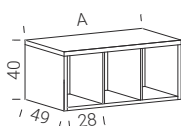

	A x B	kg max	M	Q
LCAS0002	91.5 x 40	25	445	699

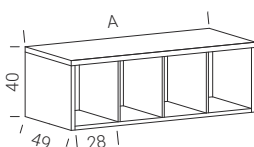

	A x B	kg max	M	Q
LCAS0003	121.5 x 40	30	500	835

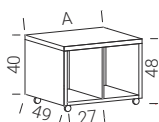

	A x B	kg max	M	Q
LCAP0001	61.5 x 40	20	292	468

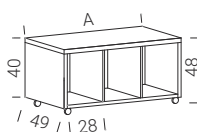

	A x B	kg max	M	Q
LCAP0002	91.5 x 40	25	350	605

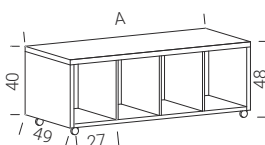

	A x B	kg max	M	Q
LCAP0003	121.5 x 40	30	406	741

**RIPIANI ESTRAIBILI / PULLOUT SHELVES / ÉTAGÈRES EXTRACTIBLES
AUSZIEHBARER BÖDEN / ESTANTES EXTRAÍBLES**

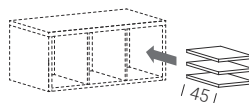

	M	Q
LACC0014	124	150

**CASSETTIERE / DRAWER UNITS / KITS DE TIROIRS
SCHUBLADENELEMENTE / CAJONERAS**

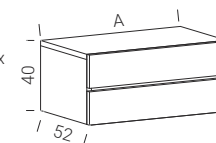
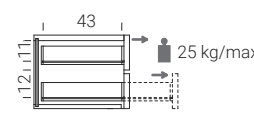

	A x B	kg max	M	Q
LCSS0001	61.5 x 40	25 x 2	498	666
LCSS0002	91.5 x 40	25 x 2	563	830
LCSS0003	121.5 x 40	25 x 2	642	923

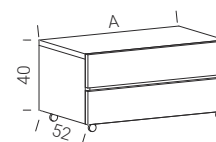

	A x B	kg max	M	Q
LCSP0001	61.5 x 40	25 x 2	411	576
LCSP0002	91.5 x 40	25 x 2	474	740
LCSP0003	121.5 x 40	25 x 2	552	834

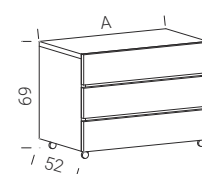

	A x B	kg max	M	Q
LCSP0004	61.5 x 69	25 x 3	524	744
LCSP0005	91.5 x 69	25 x 3	604	961
LCSP0006	121.5 x 69	25 x 3	714	1075

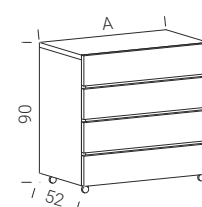

	A x B	kg max	M	Q
LCSP0008	61.5 x 90	25 x 4	652	927
LCSP0009	91.5 x 90	25 x 4	766	1213
LCSP0010	121.5 x 90	25 x 4	887	1327

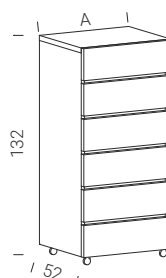

	A x B	kg max	M	Q
LCSP0007	61.5 x 132	25 x 6	876	1260
LCSP0011	91.5 x 132	25 x 6	1005	1633

**GRIGLIA PORTA ACCESSORI / ACCESSORY GRID / GRILLE PORTE-ACCESSOIRES
RASTEREINSATZ / REJILLA PORTA-ACCESORIOS**

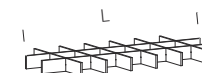
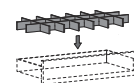

	L	Y06
CACC0012	52	49
CACC0013	82	73
CACC0014	112	96

PERSONAL

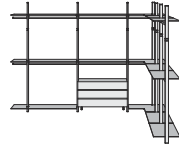

IL SISTEMA BREVETTATO EXTENDO È FORMATO DA DUE PROFILI IN ALLUMINIO ESTENSIBILI, ADATTABILI ALLE DIVERSE ALTEZZE DEGLI AMBIENTI. AGENDO SULLA LEVA A SCOMPARSA, I PROFILI SI BLOCCANO ALL'ALTEZZA DESIDERATA E SI COMPRIMONO TRA PAVIMENTO E SOFFITTO, SENZA L'UTILIZZO DI ALCUN UTENSILE O PRE-FISSAGGIO.

The patented extendo system consists of two extendable aluminium profiles that can be adapted to environments of various heights. Using the foldaway lever, the profiles can be blocked at the desired height and compressed between floor and ceiling, without having to use any kind of pre-fixing tool.

Le système breveté extendo est constitué de deux profilés extensibles en aluminium pouvant être adaptés aux différentes hauteurs des milieux. En agissant sur le levier escamotable, les profilés se verrouillent à la hauteur souhaitée et se compriment entre plancher et plafond, sans utiliser aucun outil ou préfixation.

Das patentierte System extendo besteht aus zwei ausziehbaren Aluminium-Profilen, die an unterschiedliche Raumhöhen angepasst werden können. Durch einen versenkbaren Hebel werden die Profile auf der gewünschten Höhe blockiert und zwischen Fußboden und Zimmerdecke ohne Werkzeug oder Vor-Befestigung komprimiert eingesetzt.

El sistema patentado extendo está formado por dos perfiles de aluminio extensibles, adaptables a las distintas alturas de los ambientes. Actuando sobre la palanca escondida, los perfiles se bloquean a la altura deseada y se comprimen entre el suelo y el techo, sin que sea necesario utilizar ninguna herramienta o fijación previa..

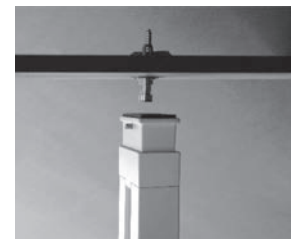
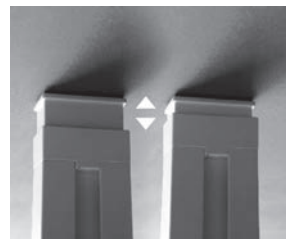
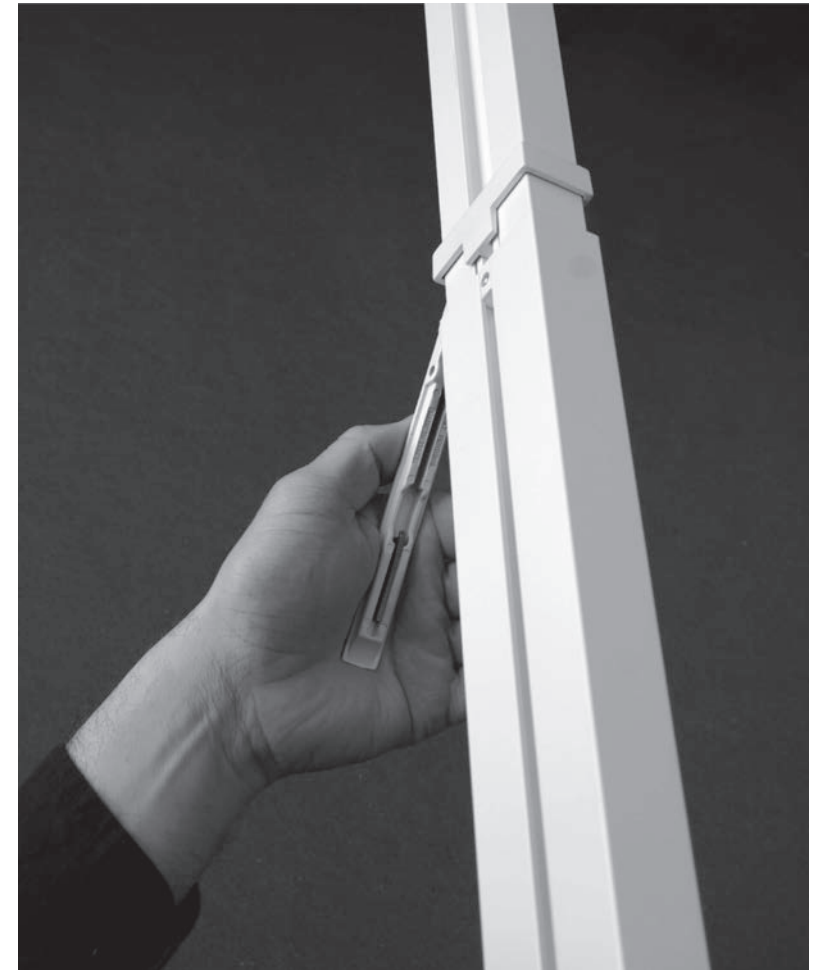



PRODUCT CONCEPT

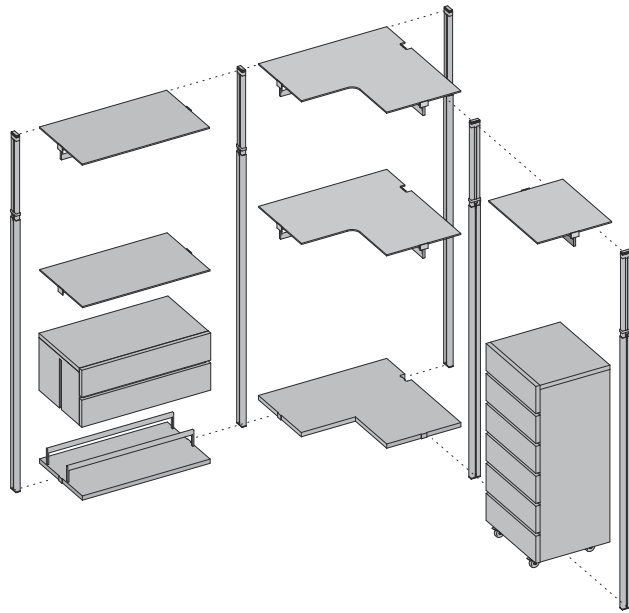

L modules
60 - 90 - 120

H modules
210 / 400

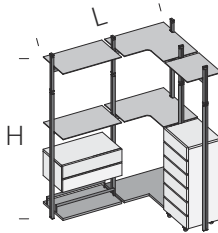

Ripiani e contenitori hanno libera posizione in altezza, (al centimetro).

Shelves and containers can be positioned at any height (to the centimetre).

Les étagères et les conteneurs peuvent être positionnés librement en hauteur (au centimètre près).

Einlegeböden und Behälter sind in der Höhe frei einsetzbar (auf den Zentimeter).

Los estantes y contenedores tienen una altura libre (al centimetro).

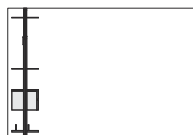

Pavimento / soffitto
Floor / ceiling
Sol / plafond
Boden / Decke
Suelo/techo

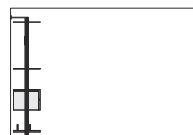

Pavimento / parete
Floor / wall
Sol / mur
Boden / Wand
Suelo / pared

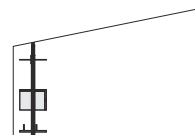

Soffitto inclinato
Sloping ceiling
Sol / plafond incliné
Schräge Decke
Techo inclinado



Sistema brevettato
Patented system
Système breveté
Patentiertes system
Sistema patentado

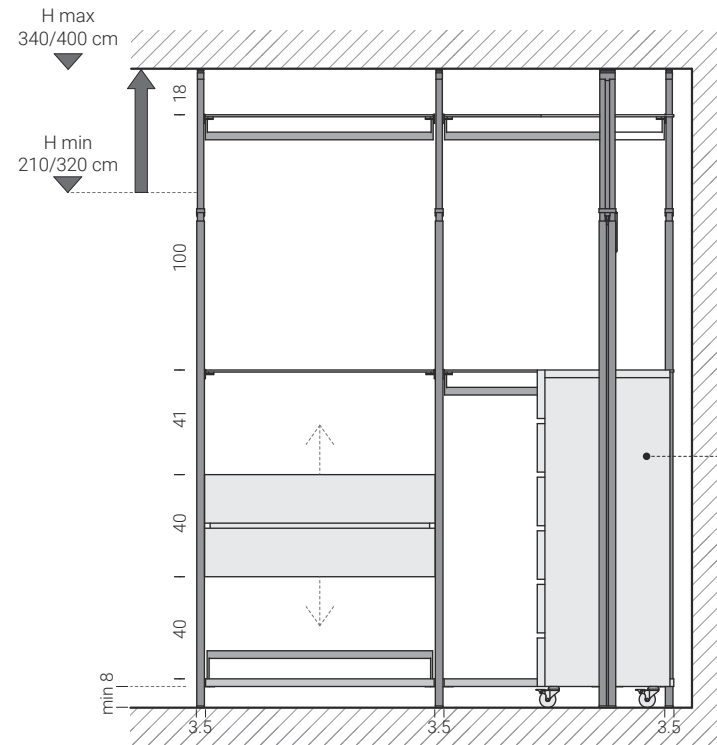

non riducibili
non-reducible items
aucune réduction possible
nicht verkürzbar
no reducibles

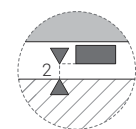
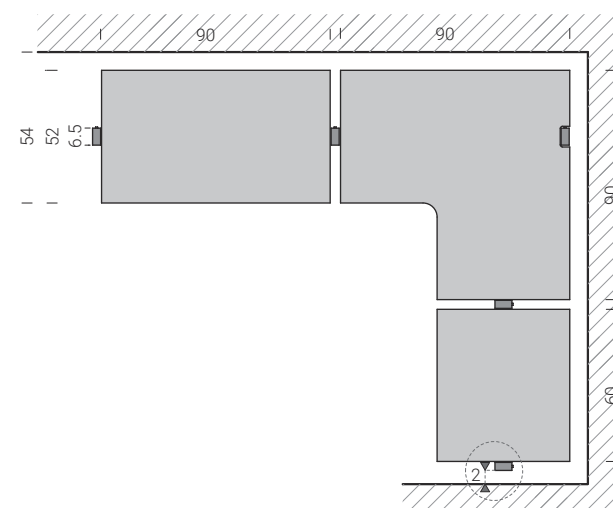

distanza minima dalle pareti 2 cm
minimum distance from walls 2 cm
distance minimale des murs 2 cm
Mindestabstand von Wänden 2 cm
distancia mínima de las paredes 2 cm



Riduzioni a misura disponibili su profili verticali, ripiani e barre appendieria.
Measurement reductions available on vertical profiles, shelves and hanging rails.
Réductions sur mesure possibles sur les profilés verticaux, les étagères et les barres de penderie.
Verkürzungen nach Kundenwunsch für vertikale Profile, Einlegeböden und Aufhängestangen verfügbar.
Reducciones de tamaño disponibles en perfiles verticales, estantes y barras de colgar.



Profilo telescopico brevettato
Patented telescopic profile
Profilé télescopique breveté
Patentiertes teleskopisches Profil
Perfil telescópico patentado

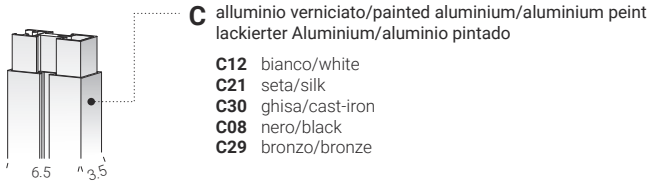

**PROFILO ESTENSIBILE EXTENDO / EXTENDO EXTENDABLE PROFILE / PROFILÉ EXTENSIBLE EXTENDO
AUSZIEHBARE PROFILE EXTENDO / BORDE EXTENSIBLE SEXTENDO**

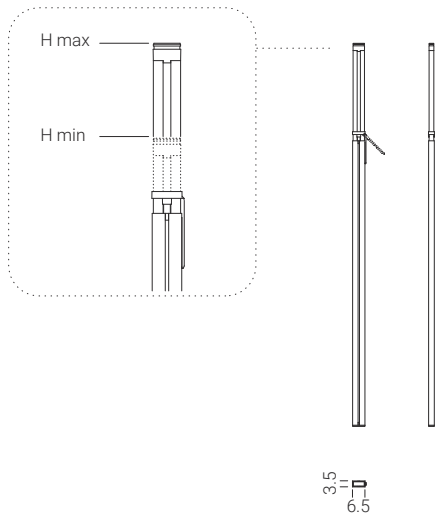

	H min - H max (cm)	C
EXTE0001	210 - 340	280
EXTE0005	320 - 400	320

**ADATTATORE PER SOFFITTO INCLINATO / SLOPING CEILING ADAPTER
ADAPTEUR POUR PLAFOND INCLINÉ / ADAPTER FÜR DACHSCHRÄGEN
ADAPTADOR PARA TECHO INCLINADO**

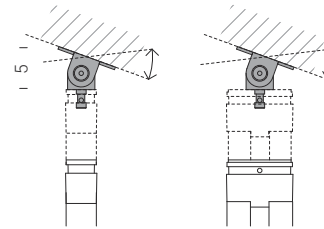

	C
EADA0001	30

**ADATTATORE PER SOFFITTO IN CARTONGESSO / PLASTER BOARD CEILING ADAPTER
ADAPTEUR POUR PLAFOND EN PLACOPLÂTRE / ADAPTER FÜR DECKEN AUS GIPSKARTON
ADAPTADOR PARA TECHO DE CARTÓN YESO**

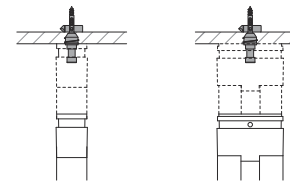

	C
EADA0002	11

i solo per cartongesso in lastre/only for plaster-board panelled ceiling/seulement pour plafonds en plaque de placoplâtre
nur für Decken aus Gipskartonplatten/sólo para techo de cartón yeso de lámina

**EXTENDO NON TELESCOPICO / EXTENDO NON-TELESCOPIC / EXTENDO NON TÉLESCOPIQUE
EXTENDO NICHT TELESKOP / EXTENDO NO TELESCÓPICO**

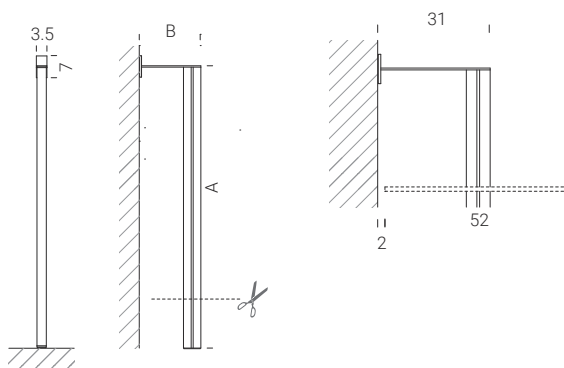

	A x B	C
EXTE0020	160 x 31	170
EXTE0021	240 x 31	200
EXTE0022	290 x 31	220

**ADATTATORE A PARETE / WALL-MOUNT ADAPTOR / ADAPTATEUR MURAL
WANDADAPTER / ADAPTADOR DE PARED**

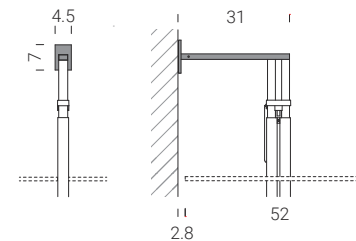

	C
EADA0015	79

utilizzabile con
usable with
utilisable avec
verwendbar mit
utilizable con

EXTE0001
EXTE0005

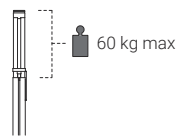

Il carico massimo sul profilo superiore è 60 kg
The maximum load on the upper profile is 60 kg
La charge maximale sur le profilé supérieur est de 60 kg
Das obere Profil kann maximal mit 60 kg belastet werden
La carga maxima en el perfil superior es de 60 kg



disponibili riduzioni a misura
custom reductions available
Verkürzungen auf Maß erhältlich
réductions sur mesure disponibles
disponibles reducciones a medida

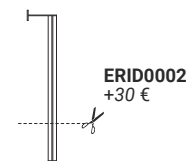
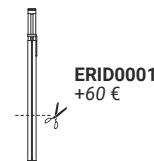

Q laccato/ lacquered/laqué
lackiert/lacado

Q05 bianco/white
Q16 seta/silk
Q17 corda/ecru
Q20 ghisa/cast-iron
Q04 nero/black
Q21 bronzo/bronze

M melaminico/ melamine/mélatiné
Melamin/melamina

M03 bianco/white
M02 rovere moka/moka oak

Q vetro laccato/lacquered glass
verre laqué/Glas lackiert
cristal lacado

Q05 bianco/white
Q16 seta/silk
Q17 corda/ecru
Q20 ghisa/cast-iron
Q14 antracite/anthracite
Q04 nero/black
Q21 bronzo/bronze

vetro trasparente/transparent glass
verre transparent/Glas transparent
cristal transparente

V06 fumè/smoked

RIPIANI / SHELVES / ÉTAGÈRES / BÖDEN / ESTANTES

	A x 52 x 3	kg/ml	M	Q
	60 x 52 x 3	20	110	148
	90 x 52 x 3	20	124	181
	120 x 52 x 3	20	139	216

	A x 52 x 3	C	kg/ml	M	Q
	100 x 52 x 3	60	20	149	213
	130 x 52 x 3	90	20	168	251
	160 x 52 x 3	120	20	186	289

	90 x 90 x 3	kg/ml	M	Q
	90 x 90 x 3	20	257	345
	90 x 90 x 3	20	257	345

**RIPIANI CON BARRA / SHELVES WITH BARS / ÉTAGÈRES AVEC BARRE
BÖDEN MIT STANGEN / ESTANTES CON BARRA**

	A x 52 x 3	kg/ml	M	Q
	60 x 52 x 3	20	149	187
	90 x 52 x 3	20	174	231
	120 x 52 x 3	20	195	272

	A x 52 x 3	C	kg/ml	M	Q
	100 x 52 x 3	60	20	189	253
	130 x 52 x 3	90	20	218	301
	160 x 52 x 3	120	20	242	345

	90 x 90 x 3	kg/ml	M	Q
	90 x 90 x 3	20	336	425
	90 x 90 x 3	20	336	425

**RIPIANI IN VETRO / GLASS SHELVES / ÉTAGÈRES EN VERRE
BÖDEN AUS GLAS / ESTANTES DE CRISTAL**

	A x 52 x 1	kg/ml	V06	Q
	60 x 52 x 1	25	146	183
	90 x 52 x 1	25	172	226
	120 x 52 x 1	25	197	269

	A x 52 x 1	C	kg/ml	V06	Q
	100 x 52 x 1	60	25	177	237
	130 x 52 x 1	90	25	234	312
	160 x 52 x 1	120	25	225	321

	90 x 90 x 1	kg/ml	V06	Q
	90 x 90 x 1	25	451	544
	90 x 90 x 1	25	451	544

**RIPIANI IN VETRO CON BARRA / GLASS SHELVES WITH BARS / ÉTAGÈRES EN VERRE AVEC BARRE
BÖDEN AUS GLAS MIT STANGEN / ESTANTES DE CRISTAL CON BARRA**

	A x 52 x 1	kg/ml	V06	Q
	60 x 52 x 1	25	187	223
	90 x 52 x 1	25	223	277
	120 x 52 x 1	25	254	326

	A x 52 x 1	C	kg/ml	V06	Q
	100 x 52 x 1	60	25	218	278
	130 x 52 x 1	90	25	285	363
	160 x 52 x 1	120	25	282	377

	90 x 90 x 1	kg/ml	V06	Q
	90 x 90 x 1	25	527	620
	90 x 90 x 1	25	527	620

disponibili riduzioni a misura (prezzo per 1 taglio)
custom reductions available (price for 1 cut)
réductions sur mesure disponibles (prix pour 1 coupe)
Verkürzungen auf Maß erhältlich (Preis für 1 Schnitt)
disponibles reducciones a medida (precio por 1 corte)

CRID0002 wood +30 €

CRID0002 wood +30 €

CRID0002 wood +30 €

CRID0002 wood +30 €

CRID0006 wood +40 €

CRID0005 glass +65 €

CRID0005 glass +65 €

CRID0005 glass +65 €

CRID0005 glass +65 €

CRID0008 glass +75 €

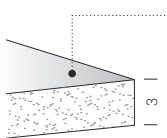

Q laccato/ lacquered/laqué
lackiert/lacado

- Q05** bianco/white
- Q16** seta/silk
- Q17** corda/ecru
- Q20** ghisa/cast-iron
- Q04** nero/black
- Q21** bronzo/bronze

M melaminico/ melamine/mélatiné
Melamin/melamina

- M03** bianco/white
- M02** rovere moka/moka oak

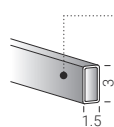

C alluminio verniciato/painted aluminium/aluminium peint
lackierter Aluminium/aluminio pintado

- C12** bianco/white
- C21** seta/silk
- C30** ghisa/cast-iron
- C08** nero/black
- C29** bronzo/bronze

**RIPIANO PORTASCARPE / SHOE RACK SHELF / ÉTAGÈRES PORTE-CHAUSSURES
BODEN SCHUHABLAGE / ESTANTE PORTAZAPATOS**

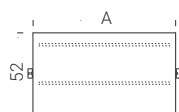

	A x 52 x 3	kg/ml	M	Q
CRIP0018	60 x 52 x 3	20	213	249
CRIP0019	90 x 52 x 3	20	247	301
CRIP0020	120 x 52 x 3	20	272	345

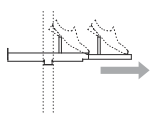
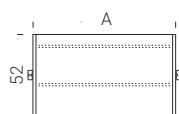

	A x 52 x 3	kg/ml	M	Q
CRIP0024	60 x 52 x 3	15	327	392
CRIP0025	90 x 52 x 3	15	363	435
CRIP0026	120 x 52 x 3	15	380	456

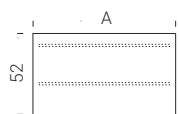

	A x 52 x 3	kg/ml	M	Q
CRIP0021	60 x 52 x 3	20	192	228
CRIP0022	90 x 52 x 3	20	226	281
CRIP0023	120 x 52 x 3	20	251	324

**RIPIANO ESTRAIBILE / PULLOUT SHELF / ÉTAGÈRE EXTRACTIBLE
AUSZIEHBARER BODEN / ESTANTE EXTRAIBILE**

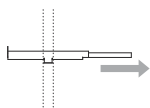
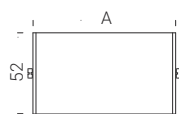

	A x 52 x 3	kg/ml	M	Q
CRIP0027	60 x 52 x 3	15	213	249
CRIP0028	90 x 52 x 3	15	236	290
CRIP0029	120 x 52 x 3	15	266	339

**PORTAPANTALONI / TROUSER RAIL / PORTE-PANTALONS
HOSENHALTER / PORTAPANTALONES**

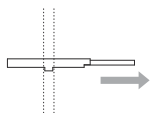

	A x 52 x 3	kg max	M	Q
CACC0020	60 x 52 x 3	10	379	386
CACC0021	90 x 52 x 3	10	424	431
CACC0022	120 x 52 x 3	10	494	501

**BARRA PORTABITI / CLOTHES RAIL / BARRE PORTE-VÊTEMENTS
KLEIDERSTANGE / BARRA PERCHERA**

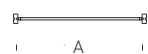

	A	kg/ml	C
CBAR0001	60	30	62
CBAR0002	90	30	68
CBAR0003	120	30	70

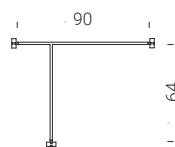

	A	kg/ml	C
CBAR0004	30	108	



	A	kg/ml	C
ABAR0003	36	30	58
ABAR0001	6	30	48

GANCIO / HOOK / CROCHET / HAKEN / GANCHO

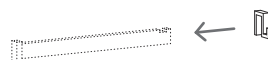

	A	kg max	C
ABAR0006	2	15	

SERVETTO

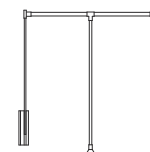
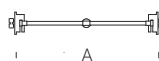

	A	kg/ml	C
CACC0004	60	10	220
CACC0004	90	10	220
CACC0004	120	10	220



disponibili riduzioni a misura (prezzo per 1 taglio)
custom reductions available (price for 1 cut)
réductions sur mesure disponibles (prix pour 1 coupe)
Verkürzungen auf Maß erhältlich (Preis für 1 Schnitt)
disponibles reducciones a medida (precio por 1 corte)

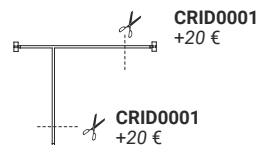
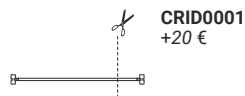
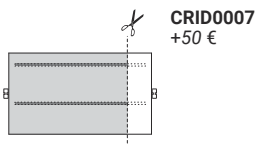

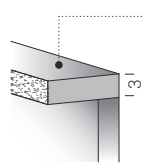

Q laccato/ lacquered/laqué
lackiert/lacado

- Q05** bianco/white
- Q16** seta/silk
- Q17** corda/ecru
- Q20** ghisa/cast-iron
- Q04** nero/black
- Q21** bronzo/bronze

M melaminico/ melamine/mélatiné
Melamin/melamina

- M03** bianco/white
- M02** rovere moka/moka oak

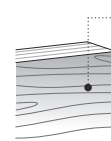

multistrato di betulla/multilayer birch
cintroplaque de bouleau/birkensperholz
multistrato de abedul

Y06 betulla/birch

CONTENITORI / CABINETS / MODULES DE RANGEMENT / BEHÄLTER / CONTENEDORES

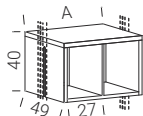
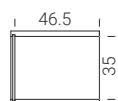

	A x B	kg max	M	Q
CCAS0001	60 x 40	20	292	472

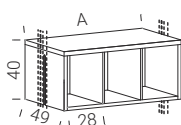

	A x B	kg max	M	Q
CCAS0002	90 x 40	25	352	612

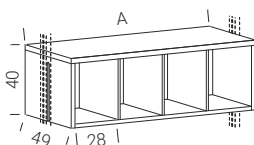

	A x B	kg max	M	Q
CCAS0003	120 x 40	30	409	752

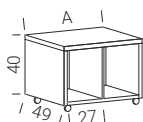

	A x B	kg max	M	Q
CCAP0001	60 x 40	20	300	480

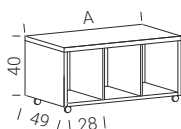

	A x B	kg max	M	Q
CCAP0002	90 x 40	25	359	620

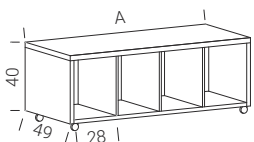

	A x B	kg max	M	Q
CCAP0003	120 x 40	30	416	760

**RIPIANI ESTRAIBILI / PULLOUT SHELVES / ÉTAGÈRES EXTRACTIBLES
AUSZIEHBARER BÖDEN / ESTANTES EXTRAÍBLES**

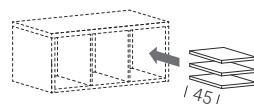

	M	Q
CACC0023	124	150

**CASSETTIERE / DRAWER UNITS / KITS DE TIROIRS
SCHUBLADENELEMENTE / CAJONERAS**

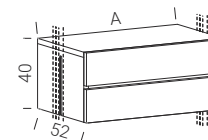
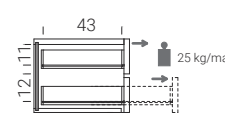

	A x B	kg max	M	Q
CCSS0001	60 x 40	25 x 2	414	584
CCSS0002	90 x 40	25 x 2	479	753
CCSS0003	120 x 40	25 x 2	559	855

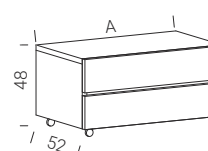

	A x B	kg max	M	Q
CCSP0001	60 x 48	25 x 2	422	592
CCSP0002	90 x 48	25 x 2	487	760
CCSP0003	120 x 48	25 x 2	567	862

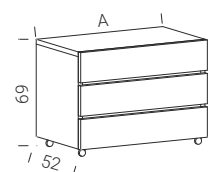

	A x B	kg max	M	Q
CCSP0007	60 x 69	25 x 3	538	764
CCSP0008	90 x 69	25 x 3	620	987
CCSP0009	120 x 69	25 x 3	733	1116

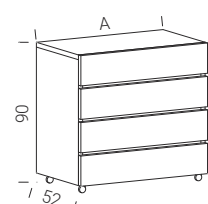

	A x B	kg max	M	Q
CCSP0015	60 x 90	25 x 4	670	952
CCSP0016	90 x 90	25 x 4	787	1246
CCSP0017	120 x 90	25 x 4	911	1380

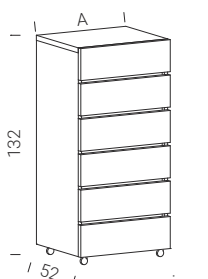

	A x B	kg max	M	Q
CCSP0013	60 x 132	25 x 6	900	1076
CCSP0014	90 x 132	25 x 6	1032	1418

**GRIGLIA PORTA ACCESSORI / ACCESSORY GRID / GRILLE PORTE-ACCESSOIRES
RASTEREINSATZ / REJILLA PORTA-ACCESORIOS**

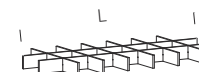
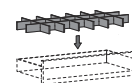

	L	Y06
CACC0012	52	49
CACC0013	82	79
CACC0014	112	96

CONDIZIONI GENERALI DI VENDITA

Le presenti condizioni generali di vendita non costituiscono offerta di vendita, ma regolano tutte le forniture effettuate dalla ditta extendo, annullando e sostituendo integralmente le precedenti condizioni generali di vendita. Tali condizioni possono essere soggette a cambiamento senza alcun preavviso. Tutti gli ordini e gli accordi si intendono perfezionati con la conferma scritta dell'azienda o con l'inizio della consegna e/o della fatturazione. Il loro perfezionamento comporta l'accettazione integrale delle presenti condizioni generali di vendita.

Ordini: la ditta extendo si riserva la facoltà insindacabile di accettare o meno gli ordini ricevuti. Nessun obbligo farà carico a extendo nell'ipotesi in cui ritenga di non accettare l'ordine. Ad ogni ordine ricevuto, extendo trasmetterà conferma d'ordine, che non potrà essere annullata o variata dall'acquirente trascorsi 8 giorni dall'invio da parte della venditrice e comunque senza il preventivo consenso scritto della venditrice. Eventuali modifiche o annullamento d'ordine al di fuori dei termini sopraccitati comporteranno comunque il pagamento da parte del cliente di una penale corrispondente al 50% del valore complessivo indicato in fattura I.V.A. inclusa.

Per ordinare: specificare il codice (es: EXTE0001), seguito dalla sigla che identifica la finitura (es: C12 e dalla descrizione articolo (es: profilo estensibile extendo). L'ordine dovrà pervenire alla venditrice tramite e-mail all'indirizzo info@extendoweb.com o per mezzo di agenti o rappresentanti.

Listino prezzi: il presente listino entra in vigore il 01/06/2022 e annulla e sostituisce i precedenti. I prezzi indicati nel presente listino rappresentano prezzi di vendita al pubblico: IVA, posa in opera, spese di deposito, di carico e scarico e qualsiasi altra sorta di prestazioni sono da intendersi escluse.

Termini di consegna: I termini di consegna per merce venduta porto franco destino si riferiscono al caricamento sui mezzi di trasporto. Le date di consegna richieste nell'ordine o nella conferma d'ordine o dalla corrispondenza, o comunque accettate dalla venditrice, devono intendersi puramente di carattere informativo e non tassativo e pertanto in nessun caso, alcun danno diretto o indiretto può essere richiesto dall'acquirente della merce e/o da eventuali terzi per la mancata o ritardata consegna della merce. Lo storno di ordini per ritardi nella consegna non è consentito senza il consenso della venditrice.

Trasporto e verifica: sul territorio UE, salvo specifico patto contrario e accettato da extendo, la merce si intende venduta franco destino. L'acquirente è tenuto a verificare la merce all'arrivo. Eventuali eccezioni per avarie, rotture non sono opponibili alla venditrice, ma al vettore a mezzo raccomandata entro 8 gg. per rilevazione danno. Gli eventuali aumenti delle spese di trasporto posteriori all'ordinazione sono a carico del compratore anche se il trasporto pattuito è a franco destino.

Porto franco magazzino rivenditore per spedizioni di valore superiore a € 900 IVA esclusa, addebito in fattura per importi inferiori (€ 40 / 80 max per spedizioni su territorio italiano, € 60 / 110 max per destinazioni paesi UE). Per importi inferiori a € 500 si richiede il pagamento anticipato.

Imballi: per specifiche condizioni di consegna le caratteristiche dell'imballo saranno di esclusiva scelta della venditrice che si riserva di addebitare il costo al committente.

Responsabilità e resi: vizi e/o difetti occulti, o comunque non riscontrabili alla consegna, devono essere denunciati per iscritto ad extendo entro 8 giorni dal ricevimento della merce, ed in ogni caso sempre prima della vendita o del collocamento in opera. L'azione si prescrive in ogni caso entro il termine di cui all'art 1498 cod. civ. I materiali considerati difettosi potranno essere, previa autorizzazione scritta, restituiti alla fornitrice a spese del committente. Se, dall'esame tecnico risulterà che il difetto è imputabile alla venditrice, sarà accreditato l'intero importo della merce resa. La venditrice non dà alcuna garanzia e non assume alcuna responsabilità per l'uso che l'acquirente fa del materiale acquistato quando tale uso non risponde alle istruzioni specifiche di ogni articolo, o la manipolazione e conservazione del materiale non viene fatta con tutti i necessari accorgimenti.

Caratteristiche tecniche: la ditta extendo si riserva la facoltà di modificare in qualunque momento e senza preavviso le caratteristiche tecniche dei prodotti, inoltre tali caratteristiche non hanno carattere impegnativo, ma semplicemente informativo. Viene stabilito che qualsiasi contestazione relativa al tipo, colore, qualità, potrà essere fatta solamente con lettera raccomandata entro e non oltre 8 giorni dal ricevimento della merce, ed in ogni caso sempre prima della vendita o del collocamento in opera.

Pagamenti: il pagamento della fattura è da farsi esclusivamente alla sede della nostra società. Ogni ritardo di pagamento da luogo a decadenza dello sconto cassa se pattuito, al rimborso spese per eventuali insoluti, e all'addebito degli interessi per il ritardato pagamento. Verranno bloccati tutti gli ordini in corso e quelli successivi saranno spediti solo in contrassegno. La merce fornita rimane di proprietà di extendo fino a totale pagamento. La mancata presentazione di reclami entro 8 giorni dal ricevimento della fattura implica piena accettazione della stessa con tutte le clausole e condizioni riportate.

Garanzia: la garanzia su tutti gli articoli prodotti ha validità 24 mesi dalla data di fatturazione. Essa non copre gli eventuali danni causati nel trasporto e decade in caso di inadeguata manutenzione. Nessuna garanzia è concessa per l'uniformità dei colori le cui lievi differenze di tonalità sono inevitabili.

Foro competente: ad ogni effetto legale e per qualsiasi controversia derivante dal rapporto disciplinato dalle presenti condizioni di vendita le parti eleggono come foro competente il Tribunale di Padova.

Validità: le presenti condizioni di vendita e di consegna s'intendono integralmente accettate dal rivenditore o committente al momento dell'ordine o con il ritiro dei prodotti, e possono essere soggette a cambiamenti senza alcun preavviso.

Informazioni tecniche: Le materie prime ed i semilavorati da esse derivati che compongono i prodotti extendo possono presentare delle difformità. Tali difformità fanno riferimento agli standard di tolleranza della casa madre produttrice della materia prima. In modo specifico per l'HPL si devono accettare e quindi considerare in tolleranza, eventuali micro inclusioni che non superino 1 mm² per m², deformazioni di superficie non soggette a carico che non superino i 2mm per metro lineare. Materie prime naturali come legno massello, legno impiallacciato, eco-touch, ottone, cuoio, potranno presentare caratteristiche difformi da quelle indicate in listino e catalogo o nei campionari extendo, pertanto si debbono riconoscere dei margini di tolleranza per quanto concerne colorazioni, tonalità, imperfezioni di superficie e il cambiamento cromatico delle superfici nel tempo, dovuto all'ossidazione provocata dalla luce e dagli agenti atmosferici propri dell'ambiente in cui sarà collocato il prodotto.

La ditta extendo si riserva la facoltà di modificare in qualunque momento e senza preavviso le caratteristiche tecniche dei prodotti, inoltre tali caratteristiche non hanno valore impegnativo, ma semplicemente informativo.

Installazione: extendo non risponde della cattiva o errata installazione degli articoli ceduti in quanto non esegue il montaggio dei propri articoli. L'acquirente non potrà in nessun caso chiedere il risarcimento dei danni eventualmente causati in occasione della installazione.

GENERAL SALES CONDITIONS

The present general sales conditions do not constitute a sales offer but govern all the supplies made by the company extendo, and totally annul and replace any previous general sales conditions. These conditions may be changed without any prior warning. All orders and agreements are to be considered finalised with the written confirmation of the company or the start of the consignment and/or invoice process. The finalising of an order or agreement implies total acceptance of the present general sales conditions.

Orders: The company extendo reserves the indisputable right to accept or refuse the orders received. Extendo is under no obligation whatsoever if it should decide to refuse an order. Extendo will also provide you an order confirmation for every order you make; any changes or cancellation of the order will be accepted for up to 2 days after the issuing (of the order) by the seller and in any case without the prior written authorisation of the seller. Any changes or cancellation of the order outside the above mentioned terms will entail a 50% fine of the total amount indicated in the invoice, V.A.T. excluded.

To order: specify the item code (eg: EXTE0001), followed by the finishing code (eg: C12), followed by the item description (eg: extendo extendable profile). The order should be sent to the seller by e-mail info@extendoweb.com or via an agent or representative.

Price list: the present price list comes into force on 01/06/2022 and annuls and replaces any previous ones. The prices indicated in the present price list are the retail prices: VAT, installation, storage, loading and unloading and any other operation or expense are not included.

Terms of delivery: The terms of delivery for goods travelling carriage free are intended when the goods are leaving extendo warehouse. Delivery dates requested on the order, in the order confirmation, in correspondence or in any case accepted by the seller, should be regarded as purely informative, not binding. Moreover, no direct or indirect damage can be requested by the purchaser of the goods and/or eventual third parties for failed or delayed consignments. Cancelling orders for late delivery is not permitted without the permission of the seller.

Transport and inspection: EU countries, unless a specific agreement has been made to the contrary and accepted in writing by extendo, the goods are intended as travelling carriage free. It is the purchaser's responsibility to inspect the goods on arrival. Any damage or breakage is not the responsibility of the seller but should be reported to the carrier by

registered post with in 8 days.

Any increase in transport expenses further to the initial order shall be charged to the purchaser even if the transport conditions are carriage free.

Retailer warehouse carriage paid for shipments of greater than € 900 value, VAT excluded, invoiced for lower amounts (€ 40 / 80 max for shipping over Italian territory, € 60 / 110 max for EU countries). Advance payment is required for purchases of less than € 500.

Packaging: for specific delivery conditions the packaging specifications shall be the exclusive choice of the seller and any extra expense shall be charged to the purchaser.

Responsibilities and yields: of receipt of the goods and in any case, before sale or installation. This action is in any case covered by the terms outlined in art. 1498 of the Civil Code. Any materials considered to be faulty can be returned to the supplier following prior written authorisation and at the expense of the purchaser. If a technical examination verifies that the fault can be imputed to the seller, the purchaser shall be credited with the entire price of the goods returned. The seller gives no guarantee and takes no responsibility for the purchaser's use of the material purchased if this is not in line with the specific instructions for each item or if the material has not been handled or stored as indicated.

Specifications: the company extendo reserves the right to change its product specifications at any time and without prior warning. Moreover, these specifications are purely informative, they are not binding. Any complaint regarding type, quality or colour must be made by registered post within 8 days of receipt of the goods and in any case before the goods are sold or installed.

Payment: all invoices must be paid to our company head offices. Any late payment automatically excludes any discounts agreed on, refunds must be paid for any outstanding debts and interest shall be charged for the payment delay period. All current orders shall be blocked and any further orders shall only be sent on "payment on delivery" terms. All supplied goods remain the property of extendo until complete payment has been made. If no complaint is presented within 8 days of the receipt of invoice this implies full acceptance of the invoice and all the clauses and conditions therein.

Guarantees: all items are covered by a 24 month guarantee starting from the invoice date. This does not cover eventual damage caused during transportation and becomes null and void in the event of incorrect maintenance. No guarantee applies to colour evenness as slight differences in tone are inevitable.

Court of jurisdiction: to all legal effects and for any dispute deriving from a relationship governed by the present sales conditions, both parties agree that the court of jurisdiction shall be the Padua Tribunal.

Validity: the placing of an order or the collection of goods implies the total acceptance of these sales and delivery conditions on the part of the retailer or purchaser. The seller has the right to change any of these conditions at any time and without prior warning.

Technical information: The raw materials and their derived semi-finished products which compose extendo products may present some discrepancies. These are based on the tolerance standards of the parent company which produces the raw material in question. More specifically, in the case of HPL, possible micro inclusions not exceeding 1 sq. mm. per sq. m. and deformations of non-load bearing surfaces that do not exceed 2 mm per linear metre should be considered acceptable and compliant with the aforementioned tolerance standards. Natural raw materials, such as solid wood, wood veneer, eco-touch, brass, leather, may present different characteristics than those indicated in the extendo price list, catalogue or sample sets, and should therefore be assessed with reasonable tolerance thresholds when presenting differences in terms of colour, tone, surface imperfections and chromatic surface changes over the course of time, due to oxidation caused by light and by atmospheric agents in the environment where the product is located.

The company Extendo reserves the right to change its product specifications at any time and without prior warning, in any case these features are of a purely informative, not binding, nature. and without prior warning.

Installation: extendo shall not answer for the poor or incorrect installation of goods sold, as the company does not assemble its own items. The purchaser has no right whatsoever, therefore, to request compensation for damage caused during installation.

CONDITIONS GÉNÉRALES DE VENTE

Les présentes conditions générales de vente ne constituent pas une offre de vente mais règlent toutes les fournitures effectuées par la société Extendo. Ainsi, elles annulent et se substituent intégralement aux précédentes conditions générales de vente. Ces conditions peuvent faire l'objet de modifications sans aucun préavis. Toutes les commandes et les accords se perfectionnent par la confirmation écrite de l'entreprise ou par le début de la livraison et/ou par l'émission de la facture. Leur perfectionnement impliquent l'acceptation intégrale des présentes conditions générales de vente.

Commandes: la société Extendo se réserve la faculté d'accepter ou de refuser les commandes qu'elle reçoit. Aucune obligation ne sera à sa charge si elle refuse une commande. Extendo transmettra la confirmation de toutes les commandes qu'elle reçoit. Les commandes ne pourront être ni annulées, ni modifiées par l'acquéreur après un délai de 2 jours suivant la date de l'envoi susvisé de la part du vendeur et, dans tous les cas, sans l'autorisation préalable et écrite du vendeur. En cas de modifications ou d'annulations de commandes effectuées hors des délais susmentionnés, le client sera tenu de verser une pénalité correspondant à 50 % de la valeur totale indiquée sur la facture, T.V.A. incluse.

Pour commander: indiquer le code (ex: EXTE0001), suivi du sigle identifiant la finition (ex: C12), suivi de la description de l'article (ex: profilé extensible extendo). La commande devra parvenir au vendeur par e-mail à l'adresse: info@extendoweb.com, ou bien par l'intermédiaire d'agents ou de représentants.

Le catalogue des prix: le présent catalogue entrera en vigueur le 01/06/2022 et annulera et remplacera le précédent. Les prix indiqués dans le présent catalogue sont les prix de vente appliqués au public: ils ne comprennent la T.V.A., la pose, les frais de dépôt, de chargement et de déchargement et tout autre type de prestation.

Délais de livraison: les délais de livraison de la marchandise vendue port payé concernent le chargement sur des moyens de transport. Les dates de livraison figurant sur la commande, sur la confirmation de la commande ou dans la correspondance, ou en tout cas acceptées par le vendeur, ont un caractère purement indicatif et n'ont aucun caractère péremptoire. Par conséquent, ni l'acquéreur de la marchandise ni aucun tiers ne pourra demander la réparation de dommages directs ou indirects causés par le défaut ou par le retard de livraison de la marchandise. La ristourne pour retard de livraison doit obligatoirement faire l'objet d'une autorisation préalable du vendeur.

Transport et vérifications: la marchandise est vendue port payé sur le territoire UE, sauf accord spécifique contraire et accepté par Extendo. L'acquéreur est tenu de contrôler la marchandise à l'arrivée. Les éventuelles exceptions portant sur des cas d'avarie ou de rupture ne seront pas opposables au vendeur mais exclusivement au transporteur. Ce dommage devra être signalé par lettre recommandée envoyée dans un délai de 8 jours. Les éventuelles augmentations de frais de transport postérieures à la commande sont à la charge de l'acquéreur, même si, selon les accords, la marchandise devait être livrée port payé.

Les expéditions d'une valeur supérieure à € 900 T.V.A. exclue sont effectuées en port payé à l'entrepôt du revendeur. Les frais de port sont en revanche facturés pour des montants inférieurs (€ 40 / 80 max pour les expéditions effectuées sur le territoire italien, € 60 / € 110 max pour les expéditions effectuées dans les pays UE). Pour tout montant inférieur à 500 € le paiement doit être effectué par avance.

Emballages: en cas de nécessités particulières de livraison, les caractéristiques de l'emballage seront déterminées par le vendeur, qui se réserve la faculté d'en facturer le coût au commettant.

Responsabilité et rendus: tout vice et/ou défaut cachés, ou en tout cas non visible au moment de la livraison doit être signalé par écrit à Extendo dans un délai de 8 jours à compter de la date de réception de la marchandise, et en tout cas toujours avant la vente ou la mise en vente. L'action se prescrit dans le délai indiqué à l'article 1498 du code civil. Les matériels considérés défectueux pourront être restitués au fournisseur aux frais du commettant, à condition que cette restitution soit autorisée par écrit. Si l'examen technique démontre que le défaut est imputable au vendeur, le prix de la marchandise rendue sera intégralement remboursé. Le vendeur ne donne aucune garantie et n'assume aucune responsabilité en cas d'usage non conforme aux instructions spécifiques de chaque article, ou en cas de manipulation et de conservation du matériel effectuées sans les précautions nécessaires.

Caractéristiques techniques: l'entreprise Extendo se réserve la faculté de modifier à tout moment et sans préavis les caractéristiques techniques des produits; ces caractéristiques n'engagent pas cette dernière, dans la mesure où elles ne sont indiquées qu'à titre indicatif. Les parties conviennent que toute contestation relative à la catégorie, à la couleur, et à la qualité ne pourra être formulée que par lettre recommandée dans un délai de 8 jours à compter de la date de réception de la marchandise, et toujours avant la vente ou la mise en vente.

Paiements: le paiement de la facture doit être effectué exclusivement auprès du siège de notre société. Tout retard de paiement donnera lieu à l'annulation de toute réduction éventuellement accordée, au remboursement des frais occasionnés par les éventuels impayés, et à la facturation des intérêts de retard. Toutes les commandes en cours seront bloquées et les commandes successives seront expédiées en contre remboursement. La marchandise fournie demeure la propriété de la société Extendo jusqu'au paiement intégral de son prix. Si aucune réclamation n'est présentée dans un délai de 8 jours à compter de la date de réception de la facture, la marchandise, les clauses et les conditions reportées seront réputées totalement acceptées.

Garantie: la garantie sur tous les articles produits a une validité de 24 mois à compter de la date d'émission de la facture. Cette garantie ne couvre pas les éventuels dommages causés pendant le transport et est exclue en cas de manutention non conforme. Aucune garantie n'est accordée pour l'uniformité des couleurs lorsque de légères différences de tons sont inévitables.

Barreau compétent: les parties conviennent que toute controverse dérivant du rapport réglementé par les présentes conditions de vente sera soumise à la compétence du Tribunal de Padoue.

Validité: les présentes conditions de vente et de livraison sont réputées être acceptées dans leur intégralité par le revendeur ou par le commettant au moment du passage de la commande ou de l'enlèvement de la marchandise, et peuvent faire l'objet de modifications sans aucun préavis.

Informations techniques: les matières premières et les produits semi finis qui en sont issus et qui composent les produits extendo peuvent présenter des irrégularités. Ces irrégularités font référence aux normes de tolérances de la maison mère productrice de la matière première. Pour l'HPL en particulier, il faut accepter et donc prendre en compte dans la tolérance d'éventuelles micro inclusions ne dépassant pas 1 mm² par m², des déformations de surfaces non soumises à des charges ne dépassant pas 2mm par mètre linéaire. Les matières premières naturelles comme le bois massif, le bois plaqué, l'eco-touch, le laiton, le cuir, pourront présenter des caractéristiques différentes de celles indiquées dans la liste des produits et le catalogue ou dans les échantillons extendo, par conséquent il faut admettre des marges de tolérance pour les couleurs, teintes, imperfections de surface et le changement chromatique des surfaces dans le temps, dû à l'oxydation provoquée par la lumière et par les agents atmosphériques propres à l'environnement où le produit sera placé.

La société Extendo se réserve la faculté de modifier à tout moment et sans préavis les caractéristiques techniques des produits. Ces dernières ne sont pas engageantes puisqu'elles ne sont fournies qu'à titre indicatif.

Installation: la société Extendo ne répond d'aucune installation incorrecte des articles cédés, dans la mesure où elle n'effectue aucun montage des produits qu'elle vend. L'acquéreur ne pourra donc en aucun cas demander la réparation d'éventuels dommages causés dans le cadre de l'installation des articles.

ALLGEMEINE GESCHÄFTSBEDINGUNGEN

Die vorliegenden allgemeinen Geschäftsbedingungen stellen kein Verkaufsangebot dar, sondern regeln alle von der Firma Extendo durchgeführten Lieferungen und annullieren und ersetzen die vorherigen allgemeinen Geschäftsbedingungen vollständig. Diese Bedingungen können ohne Vorankündigung geändert werden. Alle Bestellungen und Vereinbarungen gelten mit der schriftlichen Bestätigung der Firma oder mit Beginn der Lieferung und/oder Rechnungsstellung als abgeschlossen. Ihr Abschluss bringt die vollständige Annahme der vorliegenden allgemeinen Geschäftsbedingungen mit sich.

Bestellungen: Die Firma Extendo behält sich das Recht vor, die eingegangenen Bestellungen nach eigenem Ermessen anzunehmen oder abzulehnen. Extendo übernimmt keine Verpflichtungen für den Fall, dass sie die Bestellung ablehnt.

Für jede eingegangene Bestellung übermittelt Extendo eine Bestätigung, die vom Käufer nach Ablauf von zwei Tagen ab Versand durch die Verkäuferin und ohne vorherige Zustimmung der Verkäuferin weder storniert noch geändert werden kann. Bei eventuellen Änderungen oder der Stornierung der Bestellung außerhalb der genannten Fristen ist der Kunde in jedem Fall zur Zahlung einer Vertragsstrafe in Höhe von 50 % des in der Rechnung aufgeführten Gesamtwertes einschließlich Mehrwertsteuer verpflichtet.

So bestellen Sie: Die Artikelnummer (z. B. EXTE0001), gefolgt von der Abkürzung für die gewünschte Oberfläche (z. B. C12) und der Artikelbeschreibung (z. B. ausziehbare Profile extendo). Die Bestellung muss bei der Verkäuferin über über E-Mail unter der Adresse info@extendoweb.com oder über Handelsvertreter oder -agenten eingehen.

Preisliste: Die vorliegende Preisliste tritt am 01/06/2022 in Kraft und annulliert und ersetzt alle vorherigen Preislisten. Bei den Preisangaben in der Preisliste handelt es sich um Endverkaufspreise: Mehrwertsteuer, Aufbau, Lager-, Be- und Entladungskosten und alle weiteren Kosten sind nicht inbegriffen.

Lieferfristen: Die Lieferfristen für frei Bestimmungsort verkaufte Waren beziehen sich auf die Verladung auf die Transportmittel. Die Lieferdaten, die in der Bestellung, der Bestellbestätigung oder in der Korrespondenz gefordert werden oder jedenfalls von der Verkäuferin angenommen wurden, sind nur als Anhaltspunkte zu werten und nicht verbindlich. Daher können der Käufer der Waren und/oder eventuelle Dritte auf keinen Fall direkte oder indirekte Schäden wegen nicht erfolgter oder verspäteter

Warenlieferung geltend machen. Die Stornierung von Bestellungen aufgrund von Verspätungen bei der Lieferung ist ohne die Zustimmung der Verkäuferin nicht zulässig.

Transport und Überprüfung: Innerhalb der EU-Mitgliedsstaaten wird die Ware frei Bestimmungsort verkauft, wenn nichts anderes vereinbart und von Extendo angenommen wurde. Es obliegt dem Käufer, die Ware bei Ankunft zu überprüfen. Eventuelle Ausnahmen wegen Störungen und Brüchen sind nicht der Verkäuferin gegenüber vorzubringen, sondern innerhalb von 8 Tagen dem Spediteur per Einschreiben zur Schadensfeststellung mitzuteilen. Eventuelle Erhöhungen der Transportkosten nach der Bestellung gehen zu Lasten des Käufers, auch wenn ein Transport frei Bestimmungsort vereinbart wurde.

Frei Händlerlager für Lieferungen im Wert von mehr als € 900 zuzüglich Mehrwertsteuer, Anlastung in der Rechnung für geringere Beträge (€ 40 / 80 max für Lieferungen in Italien, € 60 / € 110 max für Lieferungen in EU-Staaten). Bei Beträgen unter 500 € ist im Voraus zu bezahlen.

Verpackung: Für spezifische Lieferbedingungen liegt die Wahl der Eigenschaften der Verpackung ausschließlich bei der Verkäuferin, die sich vorbehält, die Kosten dem Auftraggeber in Rechnung zu stellen.

Haftung und Rückgabe: Versteckte oder zumindest bei der Übergabe nicht erkennbare Mängel und/oder Fehler sind Extendo innerhalb von 8 Tagen ab Erhalt der Waren und auf jeden Fall immer vor Verkauf oder Einbau schriftlich zu melden. Der Klageanspruch verjährt in jedem Fall innerhalb der in Art. 1498 ital. Bürgerl. Gesetzbuch vorgesehenen Frist.

Das Material, das für fehlerhaft gehalten wird, kann mit vorheriger schriftlicher Genehmigung dem Lieferanten auf Kosten des Auftraggebers zurückgegeben werden. Falls die technische Untersuchung ergibt, dass der Fehler der Verkäuferin anzulasten ist, wird der gesamte Betrag für die zurückgegebene Ware gutgeschrieben.

Die Verkäuferin gewährt keine Garantie und übernimmt keine Haftung für den Gebrauch, den der Käufer von dem gekauften Material macht, wenn dieser Gebrauch den spezifischen Anweisungen für jeden einzelnen Artikel nicht entspricht oder Handling und Aufbewahrung des Materials nicht mit der erforderlichen Umsicht erfolgen.

Technische Eigenschaften: Die Firma Extendo behält es sich vor, jederzeit und ohne Vorankündigung die technischen Eigenschaften der Produkte zu ändern. Außerdem sind diese Eigenschaften nicht verbindlich, sondern dienen allein zur Information. Es gilt, dass Beanstandungen hinsichtlich Typ, Farbe und Qualität nur schriftlich per Einschreiben innerhalb von 8 Tagen ab Erhalt der Waren und auf jeden Fall nur vor deren Verkauf oder Einbau vorgebracht werden können.

Zahlungen: Die Zahlung der Rechnung hat ausschließlich an den Sitz unseres Unternehmens zu erfolgen. Jeder Zahlungsverzug führt zum Verfall des Kassaskontos, falls vereinbart, zur Kostenerstattung für eventuell unbezahlte Forderungen und zur Anlastung der Verzugszinsen. Alle laufenden Bestellungen werden gestoppt, und spätere Bestellungen erfolgen nur noch per Nachnahme. Die gelieferte Ware bleibt bis zur vollständigen Zahlung Eigentum von Extendo. Werden innerhalb von 8 Tagen ab Erhalt der Rechnung keine Beanstandungen vorgebracht, bedeutet dies die volle Annahme der Rechnung mit allen aufgeführten Klauseln und Bedingungen.

Garantie: Der Garantieanspruch auf alle Produktartikel gilt 24 Monate ab Rechnungsdatum. Der Garantieanspruch deckt keine möglichen Transportschäden und verfällt bei unangemessener Wartung. Weiterhin besteht kein Garantieanspruch auf die Einheitlichkeit der Farben, bei denen leichte Unterschiede im Farbton unausweichlich sind.

Gerichtsstand: Die Parteien wählen rechtswirksam und für alle Streitigkeiten, die sich aus dem durch die vorliegenden Geschäftsbedingungen geregelten Verhältnis ergeben, als Gerichtsstand das Gericht Padua.

Gültigkeit: Die vorliegenden Geschäftsbedingungen zu Verkauf und Lieferung gelten als vom Verkäufer oder Auftraggeber mit der Bestellung oder der Abholung der Produkte angenommen und können ohne Vorankündigung Änderungen unterzogen werden.

Technische Informationen: Rohmaterialien und ihre Halbfertigprodukte, aus dem sich die Produkte Extendo zusammensetzen, können Ungleichheiten aufweisen. Solche Ungleichheiten beziehen sich auf die Toleranzstandards des Mutterunternehmens, das das Rohmaterial herstellt. Vor allem für Produkte aus HPL müssen eventuelle Mikro-Einschlüsse angenommen und in Toleranz betrachtet werden, die 1 mm² pro m² nicht überschreiten, sowie Oberflächenverformungen, die keine Last tragen und 2mm pro Laufmeter nicht überschreiten sollen. Natürliche Rohmaterialien wie Massivholz, Furnierholz, Eco-Touch, Messing und Leder können unterschiedliche Eigenschaften aufweisen als diejenigen, die in der Preisliste, im Katalog oder im Musterkatalog Extendo angegeben sind. Deshalb müssen Toleranzspielräume anerkannt werden was die Färbungen, Farbtöne, Oberflächenunvollkommenheiten und chromatische Veränderungen der Oberflächen im Laufe der Zeit betrifft. Das alles dank der Oxidation, die vom Licht und den atmosphärischen Einflüssen verursacht wird, die sich im Raum befinden, wo das Produkt aufgestellt wird.

Die Firma Extendo behält es sich vor, jederzeit und ohne Vorankündigung die technischen Eigenschaften der Produkte zu ändern. Außerdem sind diese Eigenschaften nicht verbindlich, sondern dienen allein zur Information.

Aufbau: Extendo haftet nicht für den falschen oder fehlerhaften Aufbau ihrer abgetretenen Artikel, da sie nicht selbst die Montage ihrer Artikel übernimmt. Der Käufer kann auf keinen Fall Schadensersatz für eventuell beim Aufbau entstandene Schäden verlangen.

CONDICIONES GENERALES DE VENTA

Las presentes condiciones generales de venta no constituyen oferta de venta, pero regulan todos los suministros efectuados por la empresa extendo, anulando y sustituyendo completamente las condiciones anteriores generales de venta. Dichas condiciones pueden sufrir cambios sin ningún preaviso. Todos los pedidos y los acuerdos se considerarán perfeccionados con la confirmación por escrito de la empresa o con el inicio de la entrega y/o de la facturación. El perfeccionamiento de los mismos conllevará la aceptación total de las presentes condiciones generales de venta.

Pedidos: la empresa extendo se reserva la facultad incuestionable de aceptar o no los pedidos recibidos. extendo no contraerá ninguna obligación en el caso de que no acepte el pedido. Para cada pedido recibido, extendo transmitirá la confirmación del pedido, que no podrá anularse o modificarse por el comprador, una vez transcurridos 2 días desde el envío por parte de la vendedora y, en todo caso, sin el consentimiento previo y por escrito de la vendedora. Las posibles modificaciones o la anulación del pedido fuera del citado plazo conllevarán en todo caso, por parte del cliente, el pago de una penalización correspondiente al 50% del valor total indicado en la factura, I.V.A incluido.

Para realizar el pedido: será necesario especificar el código (por ej.: EXTE0001), seguido por la sigla que identifica el acabado (ej.: C12) y de la descripción del artículo (por ej.: borde extensibles extendo). El pedido deberá enviarse a la vendedora mediante e-mail info@extendoweb.com o mediante agentes o representantes.

Lista de precios: la presente lista de precios entrará en vigor el 01/06/2022, anulando y sustituyendo las anteriores. Los precios indicados en la presente lista representan precios de venta al público: quedan excluidos el IVA, la colocación, los gastos de depósito, de carga y descarga y cualquier otro tipo de prestación.

Plazo de entrega: el plazo de entrega para la mercancía vendida portes pagados hasta destino se refiere a la carga en los medios de transporte. Las fechas de entrega solicitadas en el pedido o en la confirmación de pedido o por la correspondencia, o en todo caso, aceptadas por la vendedora, deberán considerarse estrictamente de carácter informativo y no taxativo y, por tanto en ningún caso podrá solicitarse el daño directo o indirecto por el comprador de la mercancía y/o eventualmente por terceros por la no entrega o el retraso en la misma de la mercancía. La devolución de pedidos por retrasos en la entrega no está permitida sin el consentimiento de la vendedora.

Transporte y comprobación: en el territorio de la UE, salvo que exista un acuerdo en contrario y aceptado por extendo, la mercancía se considerará vendida franco destino. El comprador deberá comprobar la mercancía a la llegada. Los posibles daños por averías o roturas no deberán reclamarse a la vendedora, sino al transportista mediante carta certificada dentro del plazo de 8 días por constatación del daño. Los posibles aumentos de gastos de transporte posteriores al encargo del material serán a cargo del comprador aunque el transporte acordado sea franco destino.

Portes pagados almacén distribuidor para envíos de valor superior a € 900, IVA excluido, carga en factura para importes inferiores (€ 40 / 80 max para envíos al territorio italiano y € 60 / 110 max destinos países UE). Para importes inferiores a 500 € pedir el pago anticipado.

Embalajes: para condiciones específicas de entrega las características de embalaje serán a elección exclusivamente de la vendedora que se reserva adeudar el coste al comitente.

Responsabilidad y devoluciones: la reclamación contra vicios y/o defectos ocultos, o en todo caso, no detectables en el momento de la entrega deberá hacerse por escrito a extendo en el plazo de 8 días a partir de la recepción de la mercancía, y en todo caso, siempre antes de la venta o colocación del material. La acción prescribe dentro del plazo indicado en el art. 1498 del "cod. civ." (Código Civil Italiano).

Los materiales considerados defectuosos podrán devolverse, con la autorización previa y por escrito, a la proveedora debiendo correr el comitente con los gastos. Si del examen técnico resultará que el defecto es imputable a la vendedora, se le abonará el importe total de la mercancía devuelta.

La vendedora no prestará ninguna garantía ni se asumirá ninguna responsabilidad por el uso que el comprador haga del material adquirido cuando dicho uso no corresponda al indicado en las instrucciones específicas de cada artículo, o la manipulación o mantenimiento del material no se realice con las necesarias precauciones.

Características técnicas: la empresa extendo se reserva la facultad de modificar en cualquier momento y sin ningún preaviso las características técnicas de los productos. Además, dichas características no tienen carácter vinculante sino sólo informativo. Se establece asimismo que cualquier reclamación relativa al tipo, color o calidad podrá realizarse sólo mediante carta certificada dentro del plazo de 8 días a partir de la recepción de la mercancía, y en todo caso, siempre antes de la venta o de la colocación del material.

Pagos: el pago de la factura deberá realizarse exclusivamente en el domicilio social de nuestra sociedad. Cada posible demora en el pago dará lugar a la extinción del descuento a la caja si acordado, al reembolso de gastos por posibles pagos pendientes y al pago de intereses por la demora en el pago. Se bloquearán todos los pedidos por despachar y los posteriores se enviarán sólo contrareembolso. La mercancía suministrada seguirá siendo propiedad de extendo hasta el pago total del importe. La no presentación de las reclamaciones en el plazo de 8 días a partir de la recepción de la factura conllevará la aceptación total de la misma con todas las cláusulas y condiciones indicadas en ella.

Garantía: la garantía en todos los artículos producidos tiene una validez de 24 meses a partir de la fecha de facturación. Ésta no cubre los posibles daños causados durante el transporte y se extinguirá en caso de mantenimiento inadecuado. No se prestará ninguna garantía por la uniformidad de los colores cuyas pequeñas diferencias de tonalidad son inevitables.

Fuero competente: para los efectos legales y para cualquier controversia que derive de la relación regulada en las presentes condiciones de venta las partes eligen como fuero competente el de los Juzgados y Tribunales de Padua.

Validez: las presentes condiciones de venta y de entrega se considerarán aceptadas plenamente por el distribuidor o comitente en el momento del pedido o con la recepción de los productos, y pudiendo sufrir cambios sin ningún preaviso.

Información técnica: las materias primas y los semielaborados que se derivan de éstas y que forman los productos completos pueden presentar deformidades. Dichas deformidades hacen referencia a los estándares de tolerancia de la casa fabricante de la materia prima. En concreto, para el HPL, se deben aceptar y; por tanto, considerar dentro de la tolerancia, las posibles micro inclusiones que no superen 1 mm² por m², deformaciones de superficie no sujetas a carga que no superen los 2 mm por metro lineal. Las materias primas naturales como la madera maciza, la madera revestida, eco-touch, latón y cuero podrán presentar características diferentes a las indicadas en la lista y en el catálogo o en los muestrarios completos. Por tanto, se deben reconocer márgenes de tolerancia relativos a los colores, tonos, imperfecciones de superficie y modificaciones cromáticas de las superficies en el tiempo, debido a la oxidación provocada por la luz y los agentes atmosféricos del lugar en el que se colocará el producto.

La empresa extendo se reserva la facultad de modificar en cualquier momento y sin preaviso las características técnicas de los productos. Además dichas características no tienen un valor vinculante, sino simplemente informativo.

Instalación: extendo no se hace responsable de la instalación inadecuada o errónea de los artículos cedidos ya que no realiza el montaje de sus propios artículos. El comprador no podrá solicitar, en ningún caso, la indemnización por los daños causados como consecuencia de la instalación.

 **EXTENDO**
DESIGN SOURCE
M A D E I N I T A L Y



via Del Lavoro 2
35010 Trebaseleghe
PD - Italy

tel. +39 049 9387633
fax +39 049 9387644

www.extendoweb.com
info@extendoweb.com

extendo ©
ESTV0096 price list IT/EN/FR/DE/ES rev.2022